

University of Saskatchewan

Heritage Register

Megan Fritzler
Andrew Wallace

September 2013



UNIVERSITY OF
SASKATCHEWAN

Facilities Management
Division



TABLE OF CONTENTS

1.	Introduction	1-1
1.1	Purpose	1-1
1.2	Structure	1-1
1.3	Key Terms	1-4
2.	Criteria for Heritage Designation	2-1
2.1	Heritage Value	2-1
2.2	Character-Defining Elements	2-1
2.3	Commemorative Integrity	2-4
2.4	Associated Objects	2-4
2.5	Guide for Criteria	2-4
3.	Heritage Designations	3-1
4.	Standards and Guidelines for Interventions	4-1
4.1	Intervention Guide	4-1
4.2	Preservation Standards	4-1
4.3	Additional Rehabilitation Standards	4-2
4.4	Additional Restoration Standards	4-2
5.	Register of Heritage Assets: Maps & Summaries	5-1
5.1	Map of Heritage Buildings at the U of S	5-1
5.2	Map of Heritage Sites at the U of S	5-2
5.3	Register of Heritage Assets - Summary by Asset Record Number	5-3
5.4	Register of Heritage Assets - Summary in Chronological Order	5-4
6.	Architecture & Place: Making the University of Saskatchewan	6-1
7.	Register of Heritage Assets	7-1
8.	Supporting Documents	8-1
8.1	Glossary	8-3
8.2	Bibliography	8-11
8.3	Appendix: Stone	8-25

1. Introduction

1.1 Purpose

The purpose of the University of Saskatchewan Heritage Register is to provide sound, practical guidance to achieve good conservation practice with respect to *heritage assets* at the university. The Heritage Register exists in order to support heritage conservation and protect the physical assets of the university. The Heritage Register provides the University of Saskatchewan with consistent evidence of the historic and architectural significance of the buildings and sites listed.

For further information contact: Andrew Wallace, Associate Director,
Space Management & Planning
306 966 6106
andrew.wallace@usask.ca

Andrew Wallace and Megan Fritzler would like to thank the University of Saskatchewan Archives staff Patrick Hayes and Tim Hutchinson for their contributions to the research and revision of this document.

1.2 Structure

The Heritage Register consists of eight parts:

1. Introduction

2. Criteria for Heritage Designation at the University of Saskatchewan are provided for the assessment of buildings for architectural and heritage significance. These criteria include *character-defining elements* that may contribute to or indicate heritage and architectural value. A guide is included in order to ensure that the definitions and criteria provided are properly employed.

3. Heritage Designations for *heritage assets* at the University of Saskatchewan are named and described. The Register defines two categories of heritage designation: 'A' and 'B'.

4. Standards and Guidelines for Interventions are prescribed for *heritage assets*, depending on their heritage designation. These requirements and recommendations are based on the Parks Canada document *Standards and Guidelines for the Conservation of Historic Places in Canada* (2003). Refer to: www.parkscanada.gc.ca.

5. Summary Lists and Maps of *heritage assets* at the University of Saskatchewan.

6. Architecture & Place: Making The University of Saskatchewan. A brief architectural and place history of the University of Saskatchewan.



7. **Register of Heritage Assets** at the University of Saskatchewan is provided based on the established criteria. The Register includes an assessment of a property's *heritage value* according to *character-defining elements* and lists property information. Buildings or sites which have been determined to have heritage significance are recommended for protection according to 2 possible designations: A or B.

8. **Supporting Documents:** Glossary, Bibliography and Appendix.

1.3 Key Terms

▪ **Character-Defining Elements:** the materials, forms, location, spatial configurations, uses and cultural associations or meanings that contribute to the heritage value of a heritage asset, which should be retained in order to preserve its *heritage value*.

▪ **Commemorative Integrity:** *Commemorative integrity* refers to the condition or state of a *heritage asset* when the asset is healthy and whole. The word 'commemorative' refers to why a building or site is a *heritage asset*. 'Integrity' refers to its health, wholeness and honesty. A *heritage asset* possesses *commemorative integrity* when the resources directly related to the reasons for its designation as a *heritage asset* are not impaired or under threat.

▪ **Heritage Value:** the aesthetic, historic, scientific, cultural, social or spiritual importance or significance for past, present or future generations. The *heritage value* of a *heritage asset* is embodied in its *character-defining* materials, forms, location, spatial configurations, uses and cultural associations or meanings.

▪ **Heritage Asset:** a structure, building, group of buildings, district, landscape, archaeological site or other place that has been formally recognized for its *heritage value*. All of the buildings and sites listed in the *Register of Heritage Assets* and designated as category 'A' or 'B' are considered heritage assets.

▪ **Intervention:** any action that results in a physical change to an element of a *heritage asset*.

▪ **Preservation:** the action or process of protecting, maintaining, and/or stabilizing the existing materials of a *heritage asset* or of an individual component, while protecting its *heritage value*.

▪ **Rehabilitation:** the action or process of making possible a contemporary use of a *heritage asset* or an individual component, through repair, alterations and /additions, while protecting its *heritage value*.

▪ **Restoration:** the action or process of accurately revealing, recovering, or representing the state of a *heritage asset* or of an individual component, as it appeared at a particular period in history, while protecting its *heritage value*.

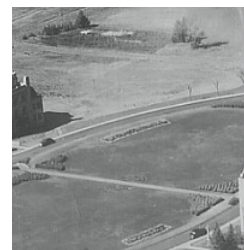
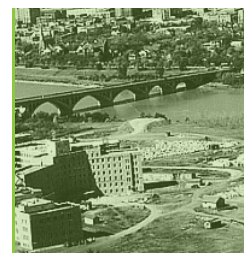

2. Criteria for Heritage Designation

2.1 Heritage Value

- **Heritage value** refers to the aesthetic, historic, scientific, cultural, social or spiritual importance or significance for past, present or future generations. *Character-defining elements* contribute to the *heritage value* of a *heritage asset*. The degree to which a building or site possesses *heritage value* determines its status within the Heritage Register. In order to be considered a *heritage asset* and be included in the Register, a building or site must possess *heritage value*.

2.2 Character-Defining Elements

- **Character-defining elements** refer to materials, forms, style, location, spatial configurations, structural systems, uses and cultural/chronological associations or meanings that contribute to the *heritage value* of a *heritage asset*.

Therefore, the *heritage value* of a building or site may be assessed by identifying and examining its *character defining elements*. The following set of *character -defining elements* may be used as a standard set of criteria, the presence of whose components in a building or site may contribute to the *heritage value* of the property.

- **Materials** Materials typical of a particular historical period, such as stone construction, slate roofs, slate floors, oak doors and windows, steel windows or brass and bronze fittings may constitute character defining elements. Architectural decoration on a building or monument may also constitute a *character defining element*. These materials and symbols may be of significance if they are reflective of the age and history of the building. The existence of these materials in their original form may indicate *heritage value*.

- **Form** The form of a building or monument may also indicate *heritage value*. With respect to the University of Saskatchewan, buildings characterized by a narrow building footprint and a scale of two to four storeys are typical of those constructed according to the original campus plan of 1909 by architects David Brown and Hugh Vallance. Buildings with low, narrow massing characterized the early campus and today contribute to the university's overall sense of place by defining the character of both interior and exterior places. Exterior courtyards framed by buildings are another *character-defining element* of form.

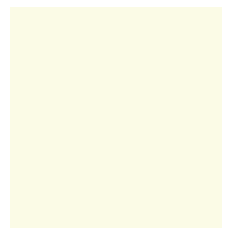

- **Style** An identifiable architectural style such as the Collegiate Gothic or Modern may constitute a *character-defining element*. Elements defining a building as Collegiate Gothic may include: arches, balustrades, buttresses, crenelation, dormers, decorative drainage spouts, slate materials, elaborate fenestration, finials, spires, carvings and grotesques, oriel windows, recessed and arched entrances, parapets, plaques, rustication or quoins applied to building corners, relief sculptures, tracery and the use of bay windows. On a building's interior, the element of vaulting is typical of the Collegiate Gothic. Collegiate Gothic architecture was selected as the style to be used for the University of Saskatchewan by the first University President, Walter Murray. Murray looked to American Universities, particularly Washington University in St. Louis, Missouri, to set a precedent for the style that would come to embody the University of Saskatchewan. Thus, older buildings adhering to this style may be considered to have *heritage value*.

The Modern architectural style may be identified by elements such as the absence of decoration, simplified massing, stripped down, repetitive detailing and the employment of new materials. Modern architecture at the University of Saskatchewan is emblematic of a wider shift in architectural paradigms away from decoration and towards functionalism, which occurred in North America following the Second World War. With respect to the university, modern buildings represent a new phase of building and construction and may be associated with a change in the planning priorities of the university.

- **Location** The siting of a building or monument in relation to the larger context of the university or city may contribute to its significance. Buildings located at the termination of axes or situated around the 'Bowl' may be indicative of their relationship to the original 1909 Campus Plan. Locations and orientations may also offer clues as to how the university was previously used or viewed and how things have changed since. The siting of a monument to mark the place of a significant event may be considered a *character defining element*.

- **Structural Systems** In a general sense, the existence of certain structural systems within a building may be a character defining element. Structural systems typical of their time or no longer commonly employed such as load bearing brick or stone, wooden post and beam systems, cast iron columns or stone foundation walls may be *character defining elements*.



- **Spatial Configuration** Outdoor spaces may constitute heritage sites. For example, outdoor courtyards and quadrangles were a critical feature of the University of Saskatchewan 1909 Campus Plan and are therefore *character defining elements* of the campus. The form, materials, scale and massing of the buildings adjacent to these courtyards may be *character defining elements* of the outdoor spaces.

Spatial configurations may also define the interior character of a building. Specifically, early campus buildings were typified by narrow interiors and double loaded corridors in order to allow for maximum natural light and ventilation. Deeper, larger floor plans are typical of later construction.

- **Uses** The use of a building by a figure historically significant to the history of the university or its greater context is an element that may be considered *character defining*. Historical events or activities that have occurred in a building or place may be *character defining elements* that may contribute to the historical significance of that building. The chronology of uses that a building undergoes may be an element that defines its character.

- **Cultural Associations or Meanings** The association of a building or monument with historically significant cultural meanings may be considered a *character defining element*. The building or monument may have significant associated meaning at a variety of scales: university, Saskatoon, Saskatchewan, Canada, or internationally. Architectural elements which convey the character of a historically significant time period may be considered *character defining elements*. Similarly, elements of a building or monument that reveal what was important to planners, builders, students and citizens of the time may be considered *character defining*. *Character defining elements* under this category may include important discoveries, patents, political appointments or movements, myths or stories contributing to the meaning of that place, plaques, designations, markers, monuments, building styles, construction methods or construction of the site by an architecturally significant figure. The architectural or design quality of a place may associate it with a certain style, time period or designer. The naming of a building or monument after a public figure or event does not necessarily deem it historically significant.



2.3 Commemorative Integrity

In order for a *character-defining element* to contribute to the *heritage value* of a place, it must retain its *commemorative integrity*. For a *character-defining element* to contribute to the *heritage value* of a building or site, it must be sufficiently intact to convey that meaning. In order to be considered a viable element of *heritage value*, the *character-defining element* must not be impaired or under threat and must effectively communicate its historical significance. Wear or weathering may also record the effects of time and express the age of an element; and therefore may contribute to the *commemorative integrity* of an element. Also, if the *commemorative integrity* of the *character-defining element* is salvageable by reasonable means, it can still be considered to possess commemorative integrity.

2.4 Associated Objects

Any objects associated with a *heritage asset* that contribute to its *heritage value* should be held in the same regard as *character-defining elements*.

2.5 Guide for Criteria

Character defining elements function as a set of indicators of *heritage value*; the existence of *character defining elements* in a building, monument or space indicates that *heritage value* may be present. The determination of *heritage value* is partially subjective, but can be reasonably assessed according to the age, architectural quality, historical significance, condition and *character defining elements* of a building or site. Even if a place is in possession of one or all of the *character defining elements*, its *heritage value* cannot be assumed, but rather should be considered and analyzed for suitability as a historically significant property. Assessing the *commemorative integrity* of a site's *character-defining elements* may aid in identifying the presence of *heritage value* in a building or site.



3. Heritage Designations

This Register defines two categories of heritage designation for University of Saskatchewan *Heritage Assets*: 'A' and 'B'.

Any *intervention* involving an 'A' listed *heritage asset* at the University of Saskatchewan is **required** to be carried out in accordance with the *Standards and Guidelines for the Conservation of Historic Places in Canada* (Parks Canada , 2003: www.parksCanada.gc.ca), wherever reasonably practicable as determined by Facilities Management Division.

Any intervention involving a 'B' listed *heritage asset* at the University of Saskatchewan is **recommended** to be carried out in accordance with the *Standards and Guidelines for the Conservation of Historic Places in Canada*, wherever reasonably practicable as determined by Facilities Management Division.

In either case, the determination of whether the *intervention* involves *Preservation, Rehabilitation* or *Restoration* shall be determined on a case-by-case basis, in accordance with the proposed functional program and budget, by Facilities Management Division, in consultation with the architect and consultant team.

Buildings and sites that have been assessed, but that are not considered to have sufficient heritage value to be formally listed are identified in the Register as 'N/A.' However, where appropriate, the information on these buildings and sites contained in the Register will be considered whenever interventions are proposed.

In the cases of Affiliated and Federated Colleges, the conclusions of this register will constitute a recommendation to those colleges.

4. Standards and Guidelines for Interventions

4.1 Intervention Guide

The following standards are broadly based on those listed in the *Standards and Guidelines for the Conservation of Historic Places in Canada* (Parks Canada, 2003). For detailed requirements and recommendations, please refer to that document. www.parkscanada.gc.ca. (Please note that separate instructions are provided in the Parks Canada document for interventions into archaeological sites, landscapes, buildings and engineering works).

The *Standards and Guidelines* are comprehensive. Standards 1 to 9 are to be applied to all *interventions*, including *preservation*, *restoration* and *rehabilitation* projects. Refer to Section 1.3 for definitions of these terms. If the intervention is a work of preservation or rehabilitation, standards 1 - 12 apply. In the case of a restoration, Standards 1-14 apply.

4.2 Preservation Standards

1. Conserve the *heritage value* of a *heritage asset*. Do not remove, replace, or substantially alter its intact or repairable *character-defining elements*. Do not move a part of a *heritage asset* if its current location is a *character-defining element*.
2. Conserve changes to a *heritage asset* which, over time, have become *character-defining elements* in their own right.
3. Conserve *heritage value* by adopting an approach calling for minimal *intervention*.
4. Recognize each heritage asset as a physical record of its time, place and use. Do not create a false sense of historical development by adding elements from other heritage assets or other properties or by combining features of the same property that never previously coexisted.
5. Find a use for a *heritage asset* that requires minimal or no change to its *character-defining elements*.
6. Protect and, if necessary, stabilize a *heritage asset* until any subsequent *intervention* is undertaken. Protect and preserve archaeological resources in place. Where there is potential for disturbance of archaeological resources, take mitigation measures to limit damage and loss of information.
7. Evaluate the existing condition of *character-defining elements* to determine the appropriate *intervention* needed. Use the gentlest means possible for any *intervention*. Respect *heritage value* when undertaking an *intervention*.
8. Maintain *character-defining elements* on an ongoing basis. Repair



character defining-elements by reinforcing their materials using recognized conservation methods. Replace in kind any extensively deteriorated or missing parts of *character-defining elements*, where there are surviving prototypes.

9. Make any *intervention* needed to preserve *character-defining elements* physically and visually compatible with the *heritage asset*, and identifiable upon close inspection. Document any *intervention* for future reference.

4.3 Additional Rehabilitation Standards

10. Repair rather than replace *character-defining elements*. Where *character-defining elements* are too severely deteriorated to repair, and where sufficient physical evidence exists, replace them with new elements that match the forms, materials, and detailing of sound versions of the same elements. Where there is insufficient physical evidence, make the form, material and detailing of the new elements compatible with the character of the *heritage asset*.

11. Conserve the *heritage value* and *character-defining elements* when creating any new additions to a *heritage asset* or any related new construction. Make the new work physically and visually compatible with, but subordinate to and distinguishable from the *heritage asset*.

12. Create any new additions or related new construction so that the essential form and integrity of a *heritage asset* will not be impaired if the new work is removed in the future.

4.4 Additional Restoration Standards

13. Repair rather than replace *character-defining elements* from the restoration period. Where *character-defining elements* are too severely deteriorated to repair and where sufficient physical evidence exists, replace them with new elements that match the forms, materials and detailing of sound versions of the same element

14. Replace missing features from the restoration period with new features whose forms, materials and detailing are based on sufficient physical, documentary and/or oral evidence.

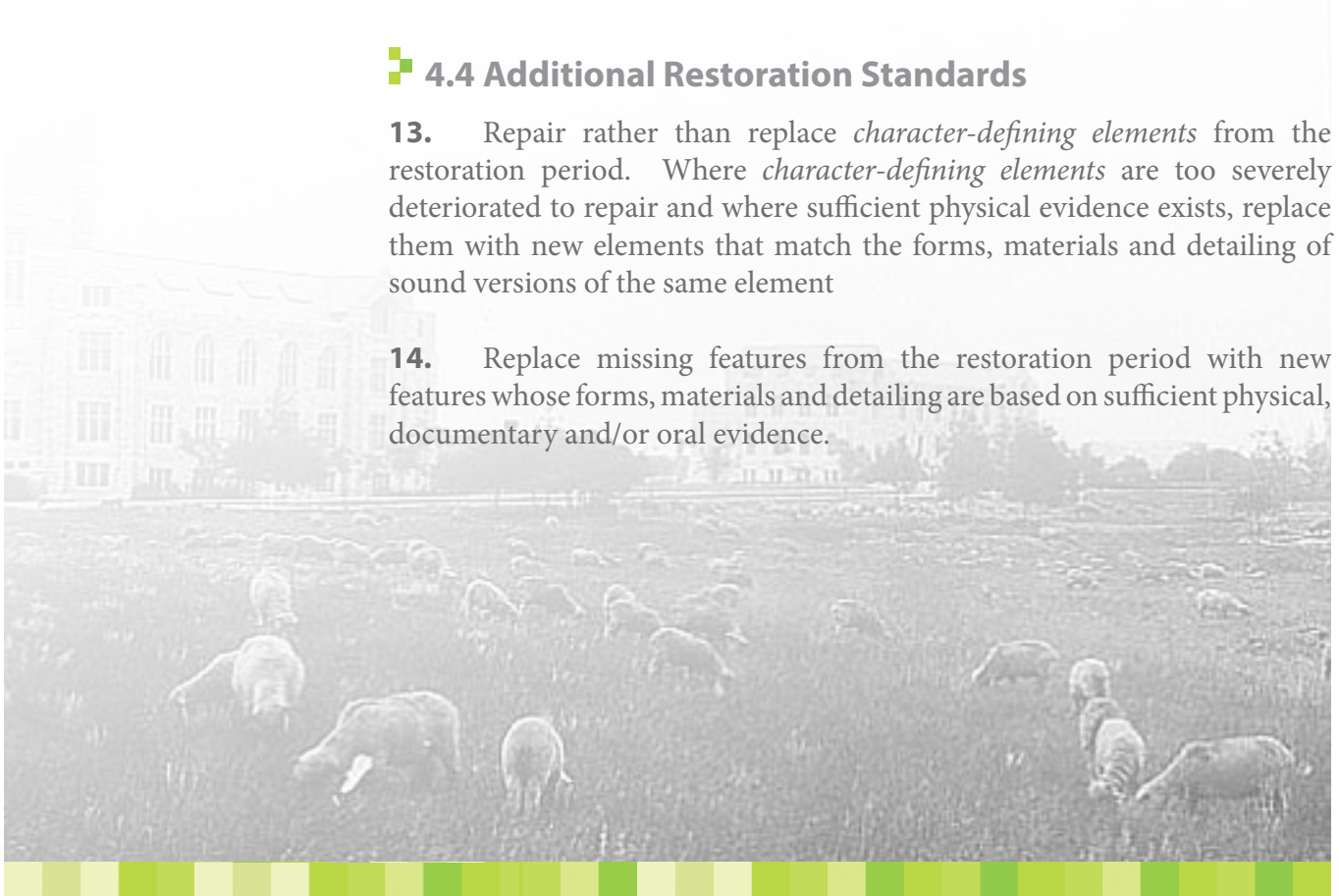

5. Register of Heritage Assets: Maps & Summaries

5.1 Map of Heritage Buildings at the U of S

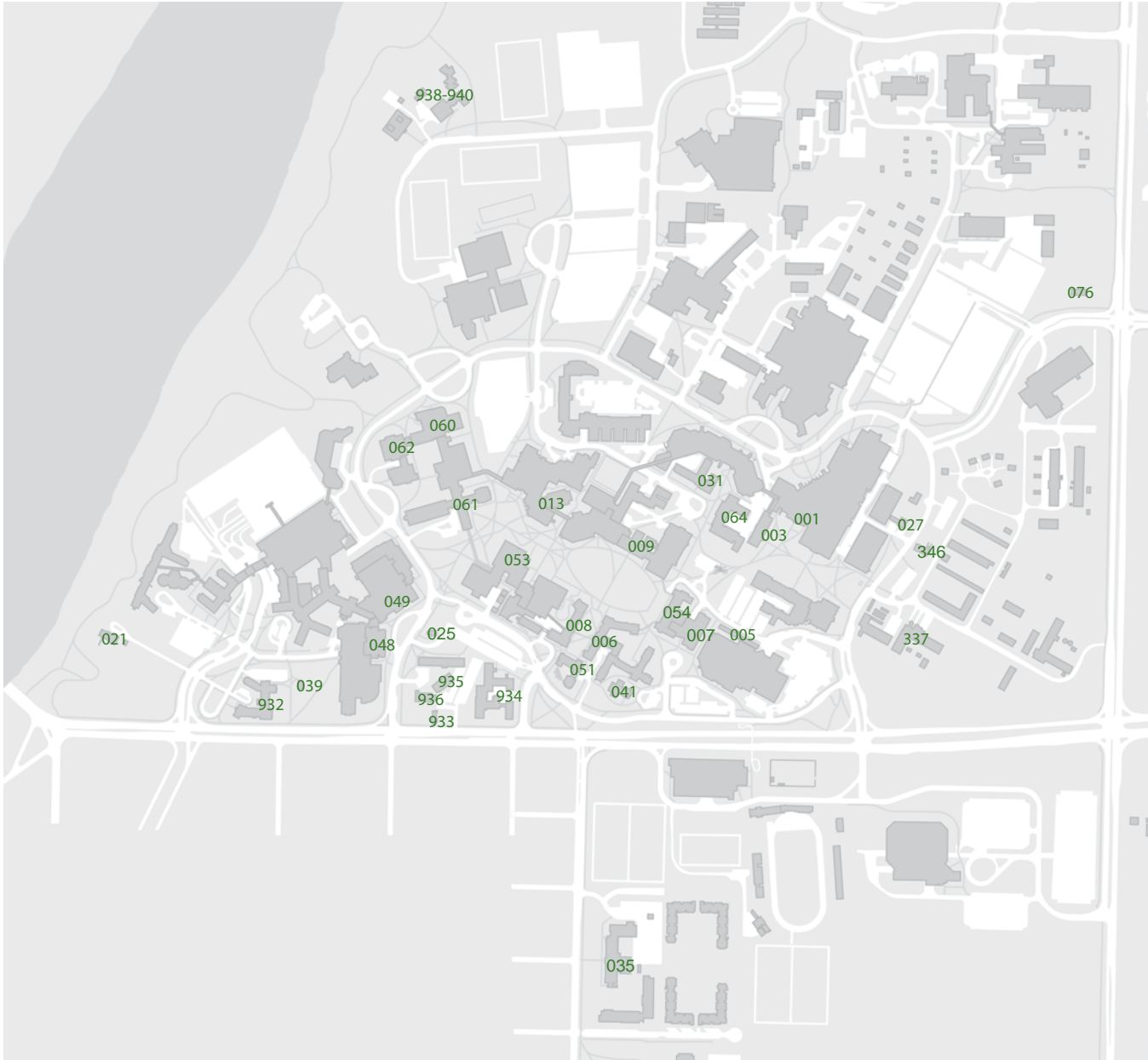

* Ernest Linder's Studio and 'Gus' Kenderdine's Cabin located at Emma Lake Kenderdine Campus

Heritage Buildings **N** ↑

5.2 Map of Heritage Sites at the U of S

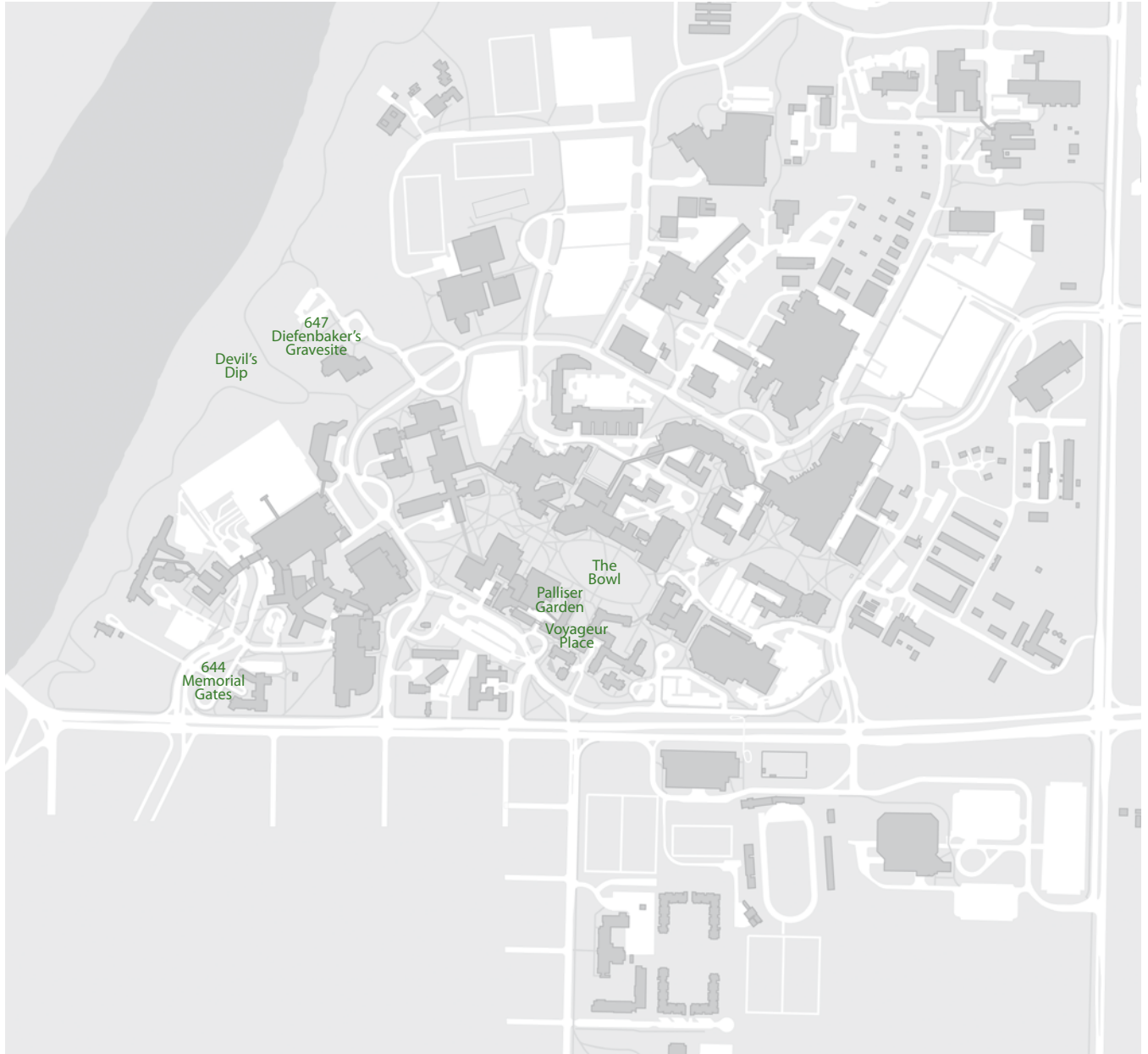

Heritage Sites **N** ↑

5.3 Register of Heritage Assets by Asset Record Number

Heritage Buildings by Asset Record Number

001	Engineering Building	'B' Listed
003	Archaeology Building	'A' Listed
005	Horticulture Building	'B' Listed
006	Saskatchewan Hall	'A' Listed
007	Administration Building	N/A
008	Qu'Appelle Hall	'A' Listed
009	Physics Building	'A' Listed
013	Thorvaldson Building	'A' Listed
021	President's Residence	'A' Listed
025	Observatory	'A' Listed
027	Poultry Science Building	'B' Listed
031	Kirk Hall	N/A
035	Williams Building	'B' Listed
039	Little Stone School	'A' Listed
041	University Club	'B' Listed
048	Dental Clinic	'B' Listed
049	Health Sciences Building	'B' Listed
051	Memorial Union Building	'B' Listed
053	Murray Building	'B' Listed
054	Peter MacKinnon Building	'A' Listed
060	Commerce Building (ESB)	N/A
062	Law Building	'A' Listed
061	Arts Building	N/A
064	John Mitchell Building	N/A
076	Seed Barn	N/A
337	Stone Barn	'A' Listed
346	Feed Elevator	'B' Listed
932	St. Andrew's College - Affiliated College	'A' Listing Recommended
933	Rugby Chapel	'A' Listed
934	St. Thomas More College - Federated College	'B' Listing Recommended
935	College of Emmanuel and St. Chad	'A' Listed
936	Emmanuel and St. Chad Chapel	'B' Listed
938-40	Lutheran Seminary - Affiliated College	'A' Listing Recommended
	Ernest Lindner Studio	'B' Listed
	'Gus' Kenderdine Studio	'B' Listed

Heritage Sites by Asset Record Number

644	Memorial Gates	'A' Listed
647	Diefenbaker's Gravesite	'A' Listed
	Devil's Dip	N/A
	The Bowl	'A' Listed
	Palliser Garden	'B' Listed
	Voyageur Place	'B' Listed



5.4 Register of Heritage Assets in Chronological Order

Heritage Buildings in Chronological Order

1887	Little Stone School (039)	'A' Listed
1913	Peter MacKinnon Building (054)	'A' Listed
1911	College of Emmanuel and St. Chad (935)	'A' Listed
1912	Engineering Building (001)	'B' Listed
1913	University Club (041)	'B' Listed
1912	Stone Barn (337)	'A' Listed
1912	Saskatchewan Hall (006)	'A' Listed
1913	President's Residence (021)	'A' Listed
1911	Rugby Chapel (933)	'A' Listed
1915	Seed Barn (076)	N/A
1924	Horticulture Building (005)	'B' Listed
1916	Qu'Appelle Hall (008)	'A' Listed
1919	Poultry Science Building (027)	'B' Listed
1921	Physics Building (009)	'A' Listed
1923	St. Andrew's College (932)-Affiliated College	'A' Listing Recommended
1924	Thorvaldson Building (013)	'A' Listed
1929	Archaeology Building (003)	'A' Listed
1930	Observatory (025)	'A' Listed
1931	Williams Building (035)	'B' Listed
1935	Ernest Lindner Studio	'B' Listed
1936	'Gus' Kenderdine Studio	'B' Listed
1949	Kirk Hall (031)	N/A
1949	John Mitchell Building (064)	N/A
1950	Health Sciences Building (049)	'B' Listed
1955	Memorial Union Building (051)	'B' Listed
1951	Feed Elevator (346)	'B' Listed
1956	Murray Building (053)	'B' Listed
1956	St. Thomas More College (934)-Federated College	'B' Listing Recommended
1967	Arts Complex (061)	N/A
1966	Emmanuel and St. Chad Chapel (936)	'B' Listed
1967	Commerce (ESB) (060)	N/A
1967	Law Building (062)	'A' Listed
1968	Lutheran Seminary (938-940)-Affiliated College	'A' Listing Recommended
1979	Dental Clinic (048)	'B' Listed
1987	Administration Building (007)	N/A

Heritage Sites in Chronological Order

	Devil's Dip	N/A
1923	The Bowl	'A' Listed
1916	Voyageur Place	'B' Listed
1928	Memorial Gates (644)	'A' Listed
ca.1965	Palliser Garden	'B' Listed
1979	Diefenbaker's Gravesite (647)	'A' Listed



6. Architecture & Place

Making the University of Saskatchewan

Andrew Wallace November 2013



Facilities Management
Division





Figure 1. The MacKinnon Building.

Architecture & Place

Making the University of Saskatchewan

Andrew Wallace



Figure 2. The Bowl: the MacKinnon Building (centre) and Saskatchewan Hall (right).

1. Introduction

The University of Saskatchewan campus is often noted for its sense of place, its material consistency and its beauty. Its centerpiece is the ['Bowl'](#), a large outdoor courtyard that forms the heart of the campus (Figure 2). The Canadian Register of Historic Places has called the picturesque collection of stone buildings that ring this space “the finest grouping of Collegiate Gothic university buildings in Canada.”¹ But the character of the University of Saskatchewan

1. *Canadian Register of Historic Places*. College Building National Historic Site of Canada. Retrieved from: <http://www.historicplaces.ca/en/rep-reg/place-lieu.aspx?id=6772>



was never inherent within the nature of its location. With the exception of the wooded banks of the South Saskatchewan River, very little remains of the original natural features of the university site. It is important to recall this environment to understand the relationship of the university as an institution to its setting. The university campus today is characterized by its stone buildings, landscaped courtyards and mature elm trees; however, this is a landscape that has been designed and constructed in every respect. A remarkable photograph exists from 1910, depicting the university site at the moment this construction began. A team of horses and ploughs stand in a flat landscape of natural prairie grasses, assembled to break ground for the construction of the MacKinnon Building (Figure 3). The creation of the campus, not only its architecture, but also its trees and open spaces, has been a collective effort of imagination and will, spanning over a century.

The architectural history of the University of Saskatchewan has been marked by a series of building booms, alternating with periods of relatively slow growth. The campus can therefore be seen as a series of historical layers, each superimposed over the previous set of existing conditions. Each layer is a record of the priorities, concerns and vision of its builders. This *Heritage Register* deals primarily with the architecture of the first two significant phases of construction at the university. It is a record of the best surviving examples of the architecture and landscapes of the University of Saskatchewan from the early and middle decades of the twentieth century. It describes these buildings and sites in detail, recording

Figure 3. The Bowl, May 28 1910: teams of horses and ploughs assembled to break ground for the construction of the MacKinnon Building. (Image: University of Saskatchewan Archives, A-12)



the elements that contribute to their architectural character and historical significance. It is hoped that the *Heritage Register* will serve as a guide to the present and future stewards of the campus, ensuring that as the university grows and adapts to new challenges, the achievements of its past will be remembered, treasured and protected.

The first phase of construction at the University of Saskatchewan occurred between 1909 and 1929. The development of the campus during this period proceeded according to a Campus Plan, created in 1909 by the architectural firm of David Brown & Hugh Vallance, of Montreal (Figure 4). Brown and Vallance also designed almost all of the buildings constructed during this period. The early architecture of the University of Saskatchewan was characterized by its traditional, Collegiate Gothic style and by the consistent use of a local dolomitic limestone, known colloquially as ‘Greystone’ (Figures 1 & 5). This first period of construction was interrupted by the stock market crash of 1929, followed by the Great Depression and the Second World War.

Figure 4. The 1909 Campus Plan by Brown and Vallance Architects. (Image: University of Saskatchewan Archives, A-5959).

Figure 5. A rendering of Saskatchewan Hall, produced by architects Brown and Vallance. (Image: University of Saskatchewan Archives, B-389-C).



As the war veterans began returning home in 1946, construction resumed and over the next quarter-century, the university undertook a massive expansion. Between 1946 and 1970, thirty major construction projects were undertaken. Buildings such as the [Murray Library](#), by Architect H.K. Black (1954-56) and the [Arts Building](#), by Shore & Moffat Architects (1958-64) were typical of a new, functionalist approach to architecture, employing simplified massing, stripped-down and repetitive detailing, and experimentation with new materials (Figures 6-8). Although the style of the post-war architecture at the university differed markedly from its antecedents, with the notable exception of the Arts Tower, an effort was made to maintain the scale and material consistency of the existing campus. The result is a university campus that is remarkable for the degree to which it has achieved a balance between aesthetic cohesion and contemporary architectural expression.



Figure 6. Murray Library, 1956 (Image: University of Saskatchewan Archives, A-617).

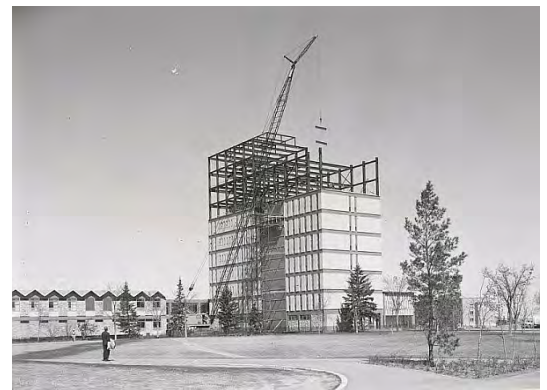

Figure 7. The addition to the Arts Tower under construction, 1964. Shore & Moffat Architects. (Image: University of Saskatchewan Archives, A-3520).

Figure 8. Architect's sketch of the Arts Building, April 1958. The Arts Tower is depicted at its original height of seven storeys, before the addition of the final four floors. (Image: University of Saskatchewan Archives, A-112).



Figure 9. Map of Whitecap Dakota settlement at Moose Woods, 1889. (Image: Saskatoon Public Library, LH-5397).

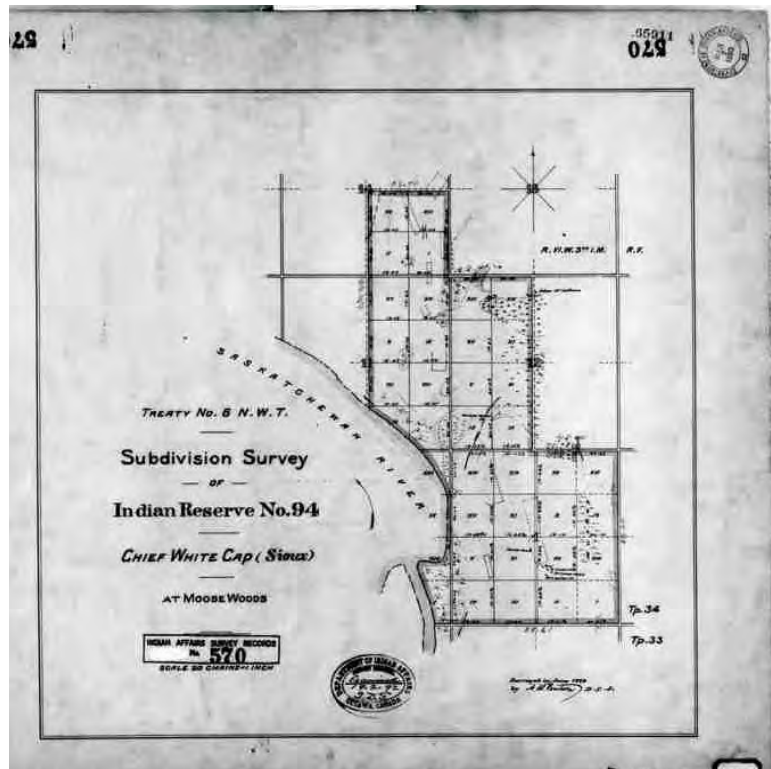

Figure 10. Map of Rupert's Land. (Image: Rupertsland Institute. http://www.rupertsland.org/about/historical_significance).

2. Before the University

To begin, it is important to acknowledge the history of the campus site prior to the creation of the university. People are believed to have entered the northern plains of Saskatchewan at the end of the last ice age, approximately 11,000 years ago. Various aboriginal peoples have occupied the area around what is now Saskatoon over time. Henry Kelsey, the first European to reach the interior of the northern plains, reported in 1690 that the area between the forks of the North and South Saskatchewan Rivers and west was inhabited by the Blackfoot people.² By the 1730's, as part of a general westward migration, the Cree had become established in this part of the plains.³ From the 1730's to the 1870's, the Nêhiyawak, or Plains Cree, developed a nomadic culture supported primarily by the bison hunt. By the 1850's, aboriginal settlements in the area around Saskatoon also included Metis hunting camps at Moose Woods and Round Prairie, south of Saskatoon.⁴ The Whitecap Dakota people took up permanent residence at Moose Woods, just south of Saskatoon, in the 1860's (Figure 9). Chief Whitecap (Wapahska) led his people to Saskatchewan to

2. Milloy, John. (1988) *The Plains Cree: Trade, Diplomacy and War 1790 to 1870* University of Manitoba Press, Winnipeg, pg. 6-7.

3. Stonechild, Blair. 'Aboriginal Peoples of Saskatchewan,' *The Encyclopedia of Saskatchewan*. Retrieved from: http://esask.uregina.ca/entry/aboriginal_peoples_of_saskatchewan.html

4. O'Brien, Jeff. (City Archivist). *A History of Saskatoon to 1914*. (2005) City of Saskatoon, pg. 2. Retrieved from: <http://www.olc.spsd.sk.ca/de/saskatoon100/students/.../SaskatoonHistoryto1914.pdf>

escape political turmoil in Minnesota, where they were living at the time (Figure 14).

In 1870, when the Hudson's Bay Company surrendered its royal charter back to the British Crown, a process was initiated to negotiate treaties with the indigenous nations of the region the British referred to as Rupert's Land (Figure 10). Treaty No. 6, an agreement between the Dominion of Canada and the Cree, Sauteaux, Nakota and Dene peoples, was signed in 1876, covering most of what is now central Saskatchewan.

Before the development of the railroad system, an extensive system of overland trails connected various aboriginal communities and fur trading posts across the territory of modern Saskatchewan. A trail from Moose Woods to Batoche crossed the current site of the University of Saskatchewan, where it joined the South Saskatchewan River on its way north (Figure 11). In the 1800's, this was a busy route travelled by Metis, Sioux and Dakota people to Batoche and to the Cree reserves near Duck Lake.⁵ The trail followed the route of what are now Broadway Avenue and University Drive. The [Memorial Gates](#) were later built at the location where this trail crossed onto the site of the university (Figures 11 & 12).

In 1872, the Dominion Lands Act was passed, setting up the Dominion Land Survey system, and offering free farmland to prospective settlers. This was a systematic plan to colonize the prairies and establish a new agrarian economy and society. Eventually, the university would be established as a critical feature of that plan. The pace of settlement was

5. Duerkop, John & Lisa Dahlie Lough. 'Along the Trails to Saskatoon'. *Saskatoon History*, Saskatoon Heritage Society, Saskatoon. Issue No. 1, 1980.

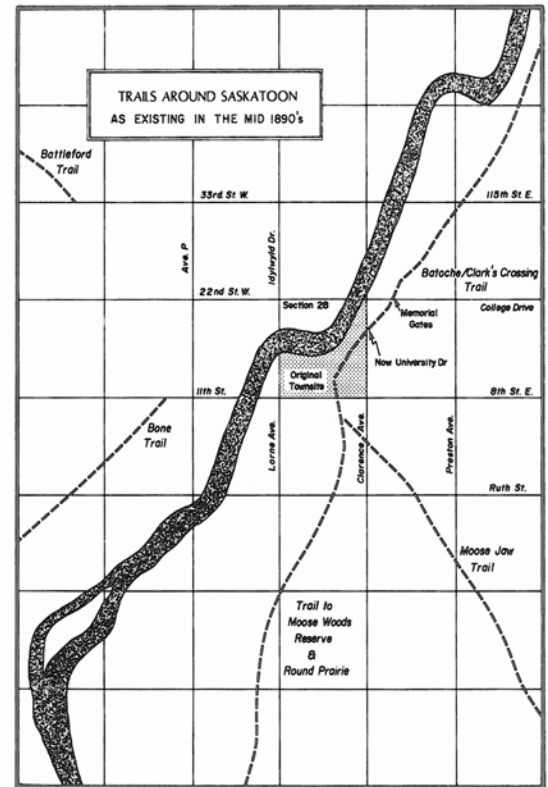

Figure 11. Map of Trails Around Saskatoon as Existing in the Mid-1890's. (Image: *Saskatoon History*, No. 1, 1980. John Duerkop and Michael Bourassa).

Figure 12. The Memorial Gates, circa 1930. (Image: University of Alberta Libraries, Postcard 2925).



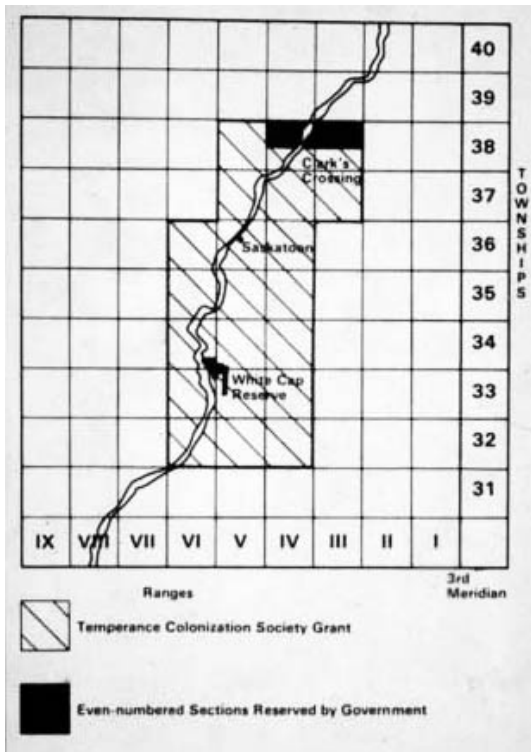

Figure 13. Map of Temperance Colonization Society grant, 1882. (Image: Saskatoon Public Library, PH-91-282).



Figure 14. Chief Wapahska (Whitecap) of the Whitecap Dakota First Nation, 1885. (Image: Saskatoon Public Library, LH-4852).

initially slow, so in 1881 the law was amended to allow private colonization companies to obtain blocks of land on condition that they were settled quickly. One of these companies was the Toronto-based Temperance Colonization Society, which aimed to establish a farming community “ever free of the accursed liquor trade”⁶ In 1882, the society was granted 21 sections of land in a block extending from the current site of Warman to Dundurn, straddling the South Saskatchewan River (Figure 13). That summer John Lake led a party to inspect the land grant and to choose a site for a new town. Near the southern end of the grant, John Lake’s party came to the Dakota-Sioux reserve at Moose Woods. Chief Wapahska (White Cap) advised Lake of a site suitable for settlement, at a place known as ‘Minnetonka’. The town of Saskatoon was established there. The temperance colony ultimately failed, but the town it established prospered as the new farming economy of Saskatchewan was established and grew.

6. Delaney, William P. (2007) *The South Saskatchewan River and the Development of Early Saskatoon 1881 – 1908, A Historical Narrative*. City of Saskatoon Community Development Branch, pg. 2.



Figure 15. Family Temperance Pledge, Temperance Colonization Society, 1885. (Image: Saskatoon Public Library, LH-8452).

3. Collegiate Gothic

The Province of Saskatchewan was incorporated in 1905, and just two years later the government of Premier Walter Scott introduced the University Act, creating the University of Saskatchewan as an institution. In 1908, Walter Murray was appointed as its first president, charged with the job of creating a new university from the ground up. That fall, he and two other members of the University board of Governors conducted a tour of several Canadian and American universities, to look at precedents. Murray was particularly impressed by the campus of Washington University in St. Louis. “The buildings are beautiful, my ideal of university buildings”, he wrote to his wife.⁷ He returned from the trip convinced that the new university should be built in the Collegiate Gothic style common to many of the universities he had seen.

In June 1909, Architect David R. Brown of the Montreal firm Brown and Vallance was interviewed and hired to plan a campus and design the first university buildings. Brown and Vallance had recently completed the Medical Building at McGill University in the Collegiate Gothic style, and were chosen mainly for their demonstrated ability to handle this style.

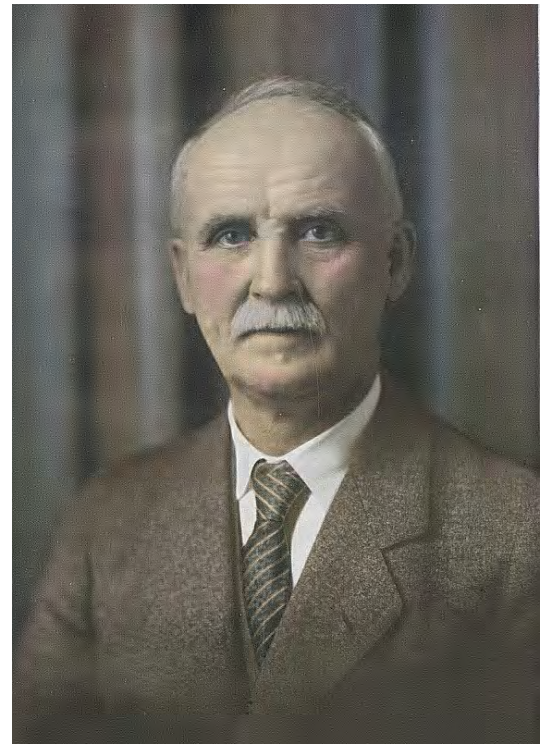

Figure 16. Walter Murray, 1931. (Image: University of Saskatchewan Archives).

7. Murray, D.R. and R.A. Murray. (1984) *The Prairie Builder - Walter Murray of Saskatchewan*. NeWest Press, Edmonton, pg. 70.

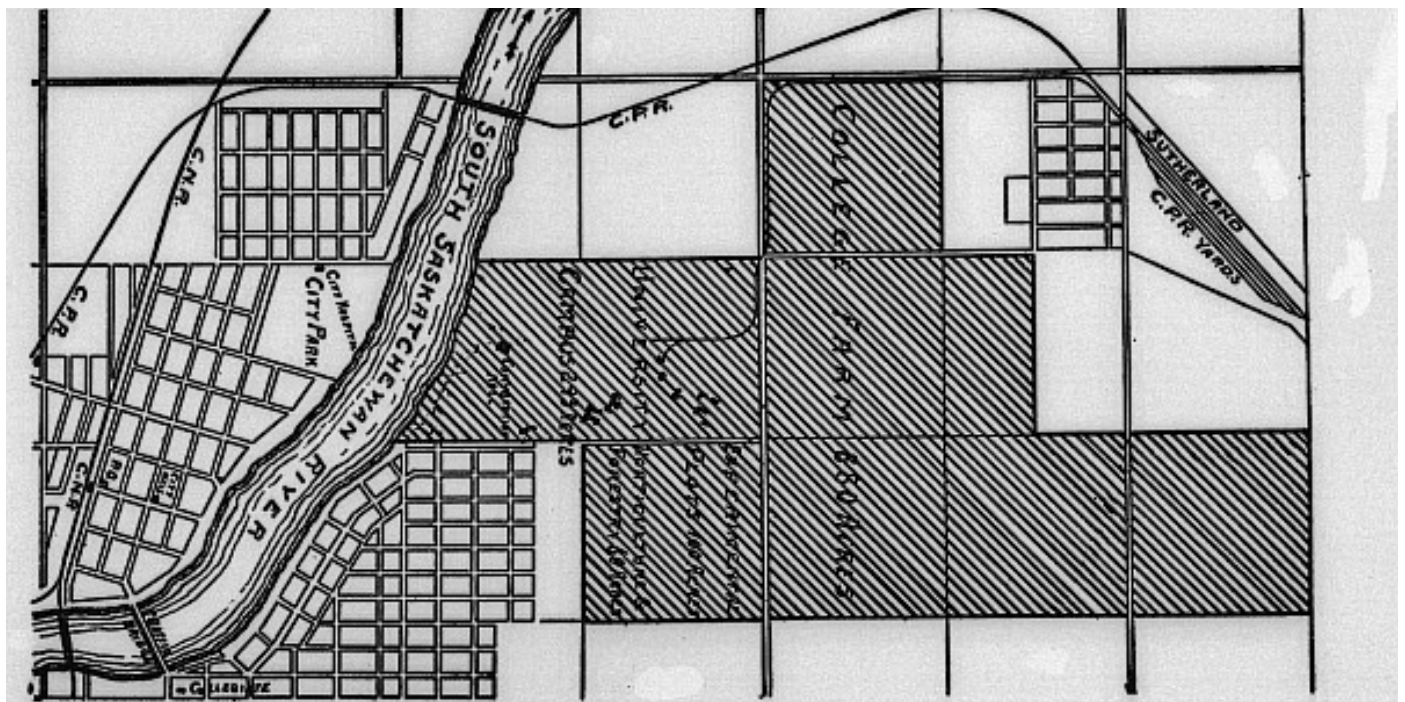

Figure 17. Map of University Land Purchase, 1909-1910. (Image: University of Saskatchewan Archives, A-6316).



Figure 18. 1909 Master Plan, Brown & Vallance Architects. Buildings actually constructed in the period 1909-1929 are shown in yellow. (Image: University of Saskatchewan Archives & Andrew Wallace)

Also in 1909, Saskatoon had been chosen to host the university, and a site had been selected. The university acquired a total of 1300 acres of land on the east bank of the South Saskatchewan River, across the river from the original town of Saskatoon (Figure 17). The purchase included 300 acres for its main campus and an additional 1000 acres of farm land. The University of Saskatchewan was the first university in Canada to incorporate an agricultural college as part of its main campus, and therefore required a large amount of arable land.⁸ The university was a critical component in the plan to develop the agricultural economy of the province.

During the early years of the university, a traditional campus was built. Its precedents were largely European and American. During the summer of 1909, Brown and Vallance developed a master plan for the campus. It was a formal design in the European Beaux-Arts tradition, characterized by a series of grand axial boulevards and landscaped gardens (Figure 4). Grouped arrangements of buildings formed a network of courtyards and quadrangles. The plan took inspiration from Enlightenment ideas of city planning, the English picturesque tradition of landscape design and the architecture of cloistered courtyards common to Oxford and Cambridge Universities.

Despite their concern for tradition, the founders of the university had a remarkable optimism and vision. Saskatoon, in 1909, was a small city of about 8000 inhabitants (Figure 19). It had only recently acquired telephone and electrical systems, and its water supply was still unreliable.⁹ But the population of the province was surging. It grew from 258,000 in 1906 to over 492,000 by 1911.¹⁰ In his planning, Walter Murray anticipated a province of two million inhabitants by 1930, and a student population of five thousand. Summarizing his concerns around the founding of the university to a friend, he remarked, "...in laying our foundation we must remember that we are building for centuries."¹¹

8. Murray, D.R. and R.A. Murray. (1984) *The Prairie Builder - Walter Murray of Saskatchewan*. NeWest Press, Edmonton, pg. 69.

9. Hayden, M. (1983) *Seeking a Balance - University of Saskatchewan, 1907-1982*. University of British Columbia Press, Vancouver, pg. 58.

10. Cottrell, Michael. 'History of Saskatchewan', *The Encyclopedia of Saskatchewan*. Retrieved from: http://esask.uregina.ca/entry/history_of_saskatchewan.html

11. Murray, D.R. and R.A. Murray. (1984) *The Prairie Builder - Walter Murray of Saskatchewan*. NeWest Press, Edmonton, pg. 54.



Figure 19. Saskatoon, 1906. (Image: Saskatoon Public Library).

The campus plan developed by Brown & Vallance matched Walter Murray’s ambition, incorporating about 60 major buildings. The quality of the early buildings constructed at the University of Saskatchewan also reflected this vision. They were built to last, and indeed all of the buildings constructed primarily of greystone between 1909 and 1929 remain in service today. ‘Greystone’ is the common term for a form of dolomitic limestone local to Saskatoon and parts of northern Saskatchewan, which was selected as the primary building material. For the early campus buildings, it was gathered from farmland around Saskatoon, and broken up into building stone on site.¹² Other materials were imported from further afield, but all were of the best quality. Cut stone window surrounds and trim were typically of Indiana Limestone. Roofs were of slate. Windows were often steel-framed, and the interiors combined terra-cotta, brick, plaster and oak. These long-lasting materials set a standard for future development at the University of Saskatchewan.

The building systems of the early campus also contained many innovative features. A central power house, one of the first buildings constructed, supplied steam heat, hot water and electricity to the rest of the campus via a system of tunnels. Two coal fired boilers supplied steam and hot water, and steam-driven generators produced electricity for lighting (Figure 20).¹³

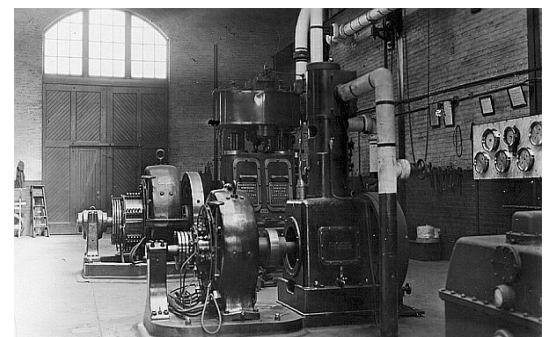

Figure 20. Central Power House, constructed 1910-12. Two steam-driven electrical generators were used to supply power to the early campus. (Image: University of Saskatchewan Archives).

12. For further information on building stones used at the University of Saskatchewan, refer to ‘Appendix: Stone’.

13. University of Saskatchewan Archives. (2006) Building the University of Saskatchewan. Retrieved from: http://scaa.usask.ca/gallery/uofs_buildings/

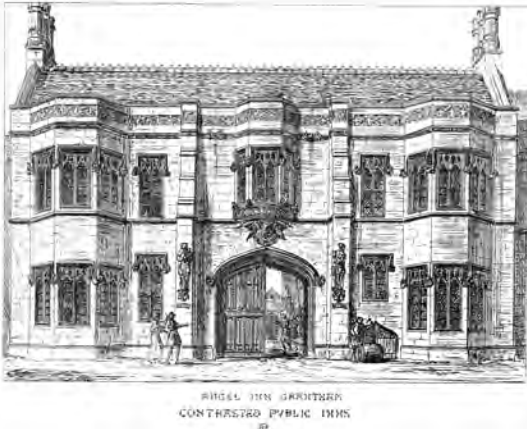

Figure 21. Drawing of the Angel Inn, from Pugin, *Contrasts*, 1836.



Figure 22. MacKinnon Building, Brown & Vallance Architects, 1910-13. (Image: FMD).



Figure 23. Carved stone gargoyle, MacKinnon Building. (Image: FMD).

The [Peter MacKinnon Building](#), formerly named the College Building, was the first building to begin construction at the university, one of five put out to tender in the spring of 1910. It stands at the head of the 'Bow', and constitutes the architectural centerpiece of the campus. The MacKinnon Building is one of the best examples of the Collegiate Gothic architectural style at the university, both in terms of its conception and realisation.

The Collegiate Gothic style was a branch of the Gothic Revival movement of the 19th and early 20th centuries, which sought to re-establish principles of mediaeval art and architecture. One of its chief proponents was Augustus Welby Pugin, the 19th century English architect and critic. His polemical book *Contrasts* (1836) framed the issue of architectural style within a wider context of social welfare and morality, setting up medieval society as an ideal, in contrast to the secular and utilitarian culture of industrial-era Britain. The Collegiate Gothic style was a later development, adopted by the Ivy League universities of the United States, and used to associate newer North American universities with the architectural and academic traditions of their ancient European predecessors, such as Oxford and Cambridge.

The MacKinnon Building features most of the elements associated with the gothic revival styles. Consider, for example, the central bay of the MacKinnon Building in comparison to the Angel Inn, a medieval building featured in Pugin's book *Contrasts* (Figures 21 & 22). Both buildings are symmetrical in composition, with the main entrance forming the central element in the design. Both entrances are recessed within a shallow pointed arch; the use of the arch, particularly the pointed or gothic arch, is a typical feature of the gothic styles. Statuary niches flank the entrances in both cases. Both elevations feature a row of three bay or oriel windows.

Carved stone ornamentation is another common feature of the Collegiate Gothic style. Walter Murray, the university's first president, requested the depiction of local fauna, such as gophers, ducks, and prairie chickens, in the carved stonework of the MacKinnon Building. Unfortunately, the eastern Canadian stone masons brought in to carry out this work were unfamiliar with these animals. They literally carved their frustrations in stone; one gargoyle, representing a mason, is shown struggling with a prairie chicken (Figure 23). Some of the depictions of Saskatchewan creatures, such as the gopher, are inaccurately rendered. Other more standard decorative motifs include acorns, oak leaves and ivy.



Figure 24. Stone Barn in 1920. (Image: University of Saskatchewan Archives).

The [Stone Barn](#) (Figure 24) was constructed at the same time as the McKinnon Building, reflecting the importance of agricultural education at the university. In its architectural style, the barn is similar to other North American dairy and livestock barns of the early twentieth century, but its large size and high-quality materials are distinctive.

The [Thorvaldson Building](#) (originally named the Chemistry Building) represents the apex of the Collegiate Gothic period at the University of Saskatchewan, reflecting the affluence of the roaring twenties in its ambitious scale, rich materials and detailed execution. It was designed by Architect David R. Brown of Montreal and began construction in 1924.



Figure 25. The Thorvaldson Building, 1924. (Image: University of Saskatchewan Archives, A-3923).



Figure 26. Chapel at King's College, Cambridge. (Image: Wikipedia).

In its form and detail, the Thorvaldson Building also illustrates the European and ecclesiastical roots of the Collegiate Gothic style better than any other building at the University of Saskatchewan. Compare, for example, the Thorvaldson Building (Figure 25) to the chapel of King's College Cambridge (Figure 26). The imposing scale of the Thorvaldson Building, its verticality, the character of its grand entrance, and its stylistic references to architectural elements such as flying buttresses, spires, and church portals make clear reference to this and other precedents in European Christian architecture.

In total, David Brown and Hugh Vallance designed 14 major buildings for the university in the period 1909 – 1929 (Figure 18). Due to their adherence to a master plan, a consistency of material character and a common architectural style, the early buildings of the University of Saskatchewan form a single coherent composition. Despite later changes in priority, technology and architectural style, the work of Brown and Vallance in establishing the early campus set a benchmark for its later development.

4. Modernism

In the period following the Second World War, a wave of social changes occurred that left an imprint on the physical layout and architecture of the University. In 1930, enrolment had been 1610 full-time students. By 1947, with war veterans returning home, enrolment had jumped to 4,310.¹⁴ The original Campus Plan had been designed for pedestrians, but in the post-war period an increasing number of private cars had begun to appear. By 1954, a series of ad hoc changes had been made to accommodate these cars: vehicular roads had been added and parking lots had been built in ways unforeseen by the 1909 Plan. Photographs from this period reveal the gardens and pedestrian avenues of the original plan cluttered with parked cars (Figure 27).



Figure 27. Postcard photograph, 1954. Note the cars parked around the 'Bowl'. (Image: University of Saskatchewan Archives, A-8844).

14. Kerr, D.C. (1998) Building the University of Saskatchewan, University of Saskatchewan, Saskatoon, pg. 8.

Figure 28. Campus Plan, 1957, Izumi, Arnott & Sugiyama Architects. (Image: University of Saskatchewan Archives, CG-23-T).

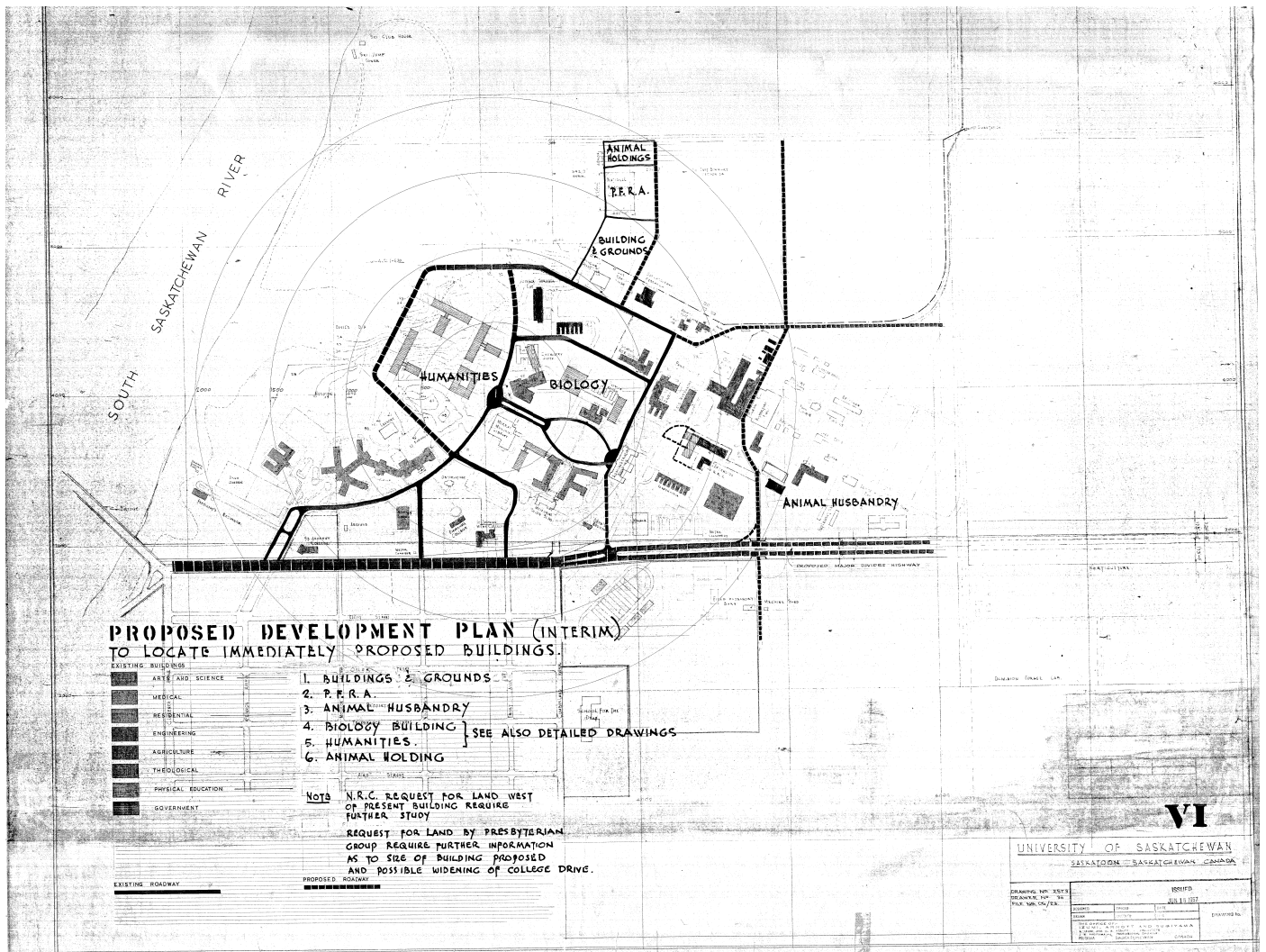



Figure 29. Model of the campus in 1961. (Image: University of Saskatchewan Archives).

Between 1954 and 1957, the architectural firm of Izumi, Arnott & Sugiyama was engaged by the University to carry out a series of planning studies (Figure 28). This work was intended to address the issue of increasing traffic congestion, to suggest locations for a number of new buildings and to provide direction for the future growth of the campus. The adoption of Izumi's plan essentially marks the abandonment of the 1909 Plan. The new plan involved the construction of a ring-road intended to provide vehicular access around the perimeter of the campus, and thereby to separate the campus into pedestrian and vehicular areas. This road was constructed, and is now called Campus Drive. Locations were proposed for several new buildings, including a Humanities complex, a Biology building and some new residence halls. Finally, the plan proposed the division of the campus into a series of functional zones: Arts, Sciences, Medical, Agricultural and Residential. All of these proposals were implemented in some form over the course of the next decade.

A photograph of a model of the campus in 1961 illustrates the effects of Izumi's recommendations (Figure 29). The construction of Campus Drive and the location of the Arts Tower effectively terminated the Bowl and cut off future development of the campus core from the river. The more direct relationship of the campus to the river implied by the 1909 Plan was altered by this new approach.



The campus was made more insular, focused on the Bowl rather than on the multiple focal points of the 1909 Plan. The Functional zoning suggested by Izumi has proved useful, and is still in effect today, but has also created problems in terms of connectivity between the various parts of the campus. Those buildings that have subsequently been built outside of Campus Drive, such as the Education Building, feel remote from the life of the central campus. However, the Izumi plan allowed the preservation of a pedestrian campus within the context of a growing student population.

Not only the planning but also the architecture of the university changed in the period following the Second World War. The [Murray Building](#), designed by architect Kioshi Izumi working under H.K. Black Architect, was built between 1954 and 1956 (Figures 30 & 31). It is architecturally significant as one of the first modernist buildings constructed at the University of Saskatchewan, and the first to use a full structural steel frame. (The Heating Plant, constructed at the same time, is also in the Modern style). Modernist architecture is characterized generally by the removal of applied ornament in favour of an articulation of material qualities, the manipulation of form and the expression of function. Decorative elements tend to be abstract and geometric rather than figural or representational. Architects of the modern period were interested in expanding the expressive range of forms, and this impulse led to designs that were no longer bound by conventions of symmetrical composition. The asymmetry of the Murray Building, in the arrangement of its forms and its elevations,

Figure 30. Architect's sketch of the Murray Building, 1954. (Image: University of Saskatchewan Archives, A-5962).



Figure 31. Photograph of the Murray Building, taken in 2013. (Image: FMD).



Figure 32. Arts Tower, Shore & Moffat Architects, 1958-60. (Image: Troy Smith, Group 2 Architecture).

Figure 33. Arts Tower, Shore & Moffat Architects, 1958-60. (Image: Troy Smith, Group 2 Architecture).



is characteristic of the period. However, it is also notable that at the moment of transition between the historicist impulse of the Collegiate Gothic and the modernist idiom of the Murray Building, a decision was made to continue the use of 'greystone' and Tyndall stone as the principal exterior materials.

The [Arts Building](#), built in two stages between 1958 and 1964, is often disparaged as ugly and out of scale with the rest of the University of Saskatchewan campus. (Fig. 5) At 11 stories, it is the tallest structure at the university, and it is unique among the buildings facing the Bowl in that it employs an enameled metal spandrel panel system in addition to Tyndall stone cladding. The other buildings facing the Bowl, while of a variety of different ages and architectural styles, have a consistent height of between two and four stories. All, with the exception of the Arts Tower and Marquis Hall (1962-64), primarily employ Greystone cladding with cut limestone trim.



Figure 34. Law-Commerce Complex, Holliday-Scott & Associates Architects, 1964-67. (Image: John Holliday-Scott).



Figure 35. Law Building from the north side, Holliday-Scott & Associates Architects, 1964-67. (Image: John Holliday-Scott).

The best architecture of the mid-twentieth century at the University of Saskatchewan was the work of John Holliday Scott and his firm Holliday-Scott & Associates. Between 1965 and 1979, Holliday-Scott designed three projects on the university campus: the [Law-Commerce Complex](#), the [Lutheran Seminary](#), and the [Dental Clinic](#). Holliday-Scott was one of the most accomplished architects of his generation working in Saskatchewan. In these three projects, Holliday-Scott took the traditional architecture of the University of Saskatchewan and translated it into a contemporary architectural language of his own invention. The Law Building, in particular, is a masterful building in which the principles of modernism are employed not as rigid precepts, but as parts of a broader framework of possible references, selected and manipulated for their expressive potential (Figures 35 & 36). In this way, the traditions of the university and of the legal profession were given a clear and contemporary form.

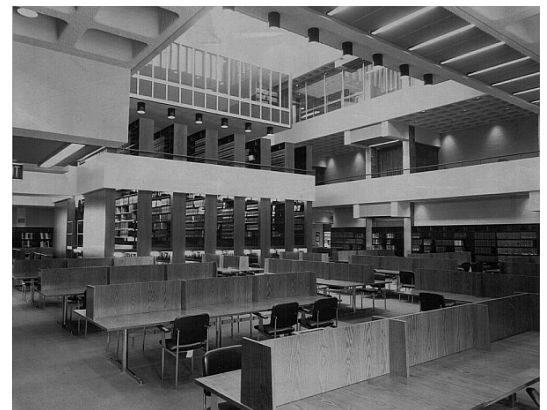

Figure 36. Law library (Image: University of Saskatchewan Archives, A-4563).

5. Conclusion

The Mexican writer and poet Octavio Paz, writing in 1990, said that “between tradition and modernity there is a bridge. When they are mutually isolated, tradition stagnates and modernity vaporizes; when joined, modernity breathes new life into tradition, and tradition responds by providing depth and gravity.”¹⁵ Over a century of development, the architecture of the University of Saskatchewan has been most successful where it has sought to create this bridge between its own traditions and its central mission of advancing scholarship and artistic works. The work of David Brown and Hugh Vallance established a compelling vision that has served as a template for the architecture and urban design of a successful university campus. That vision included specific reference to a traditional architectural style, but its lasting contribution has been as much to do with the definition of a spirit of place, reflected in a careful attention to detail, a consistency of materials, textures and colours, a sense of enclosure, and a humane scale for buildings and outdoor spaces. The best architecture of the mid twentieth century sought to reflect and accommodate the changing outlook and requirements of a contemporary university in buildings that both respected and challenged tradition. In this way, by degrees, the University of Saskatchewan was imagined, built and established as a place.

15. Paz, Octavio. (1990) Nobel Lecture: In Search of the Present. Retrieved from: http://www.nobelprize.org/nobel_prizes/literature/laureates/1990/paz-lecture.html

Figure 37. Lutheran Seminary, J. Holliday-Scott and M. Desmond Paine Architects, 1968 (Image: Saskatoon Public Library, CP-5925-B-4).



6. Bibliography

Brook McIlroy Planning & Urban Design. (2003) *Core Area Master Plan: University of Saskatchewan*. University of Saskatchewan.

Canadian Register of Historic Places. College Building National Historic Site of Canada. Retrieved from: <http://www.historicplaces.ca/en/rep-reg/place-lieu.aspx?id=6772>

City of Saskatoon Archives. (2006) *Saskatoon – a Brief History*. Retrieved from: <http://archive.is/Vuoeo>

Cottrell, Michael. 'History of Saskatchewan,' *The Encyclopedia of Saskatchewan*. Retrieved from: http://esask.uregina.ca/entry/history_of_saskatchewan.html

Delainey, William P. (2007) *The South Saskatchewan River and the Development of Early Saskatoon 1881 – 1908, A Historical Narrative*. City of Saskatoon Community Development Branch. Retrieved from: http://www.saskatoon.ca/DEPARTMENTS/Community%20Services/Communitydevelopment/Documents/cc_south.pdf

Duerkop, John & Lisa Dahlie Lough. 'Along the Trails to Saskatoon.' *Saskatoon History*, Saskatoon Heritage Society, Saskatoon. Issue No. 1, 1980.

Hayden, M. (1983) *Seeking a Balance - University of Saskatchewan, 1907-1982*. University of British Columbia Press, Vancouver.

Kerr, D.C. (1998) *Building the University of Saskatchewan*, University of Saskatchewan, Saskatoon.

Milloy, John. (1988) *The Plains Cree: Trade, Diplomacy and War 1790 to 1870*. University of Manitoba Press, Winnipeg.

Murray, D.R. and R.A. Murray. (1984) *The Prairie Builder - Walter Murray of Saskatchewan*. NeWest Press, Edmonton.

Mysyk, K. and C.L. Kulyk. (2006) *Saskatoon's Stone*. 2006.

O'Brian, Jeff. (City Archivist). *A History of Saskatoon to 1914*. (2005) City of Saskatoon. Retrieved from: <http://www.olc.spsd.sk.ca/de/saskatoon100/students/.../SaskatoonHistoryto1914.pdf>





Parkin Associates Architects and Engineers. (1963) *Appraisal of Master Plan*, University of Saskatchewan, Saskatoon.

Paz, Octavio. (1990) *Nobel Lecture: In Search of the Present*. Retrieved from: http://www.nobelprize.org/nobel_prizes/literature/laureates/1990/paz-lecture.html

Stonechild, Blair. 'Aboriginal Peoples of Saskatchewan', *The Encyclopedia of Saskatchewan*. Retrieved from: http://esask.uregina.ca/entry/aboriginal_peoplesof_saskatchewan.html

University of Saskatchewan Archives. (2006) *Building the University of Saskatchewan*. Retrieved from: http://scaa.usask.ca/gallery/uofs_buildings/



University of Saskatchewan Heritage Register

7. Register of Heritage Assets



Facilities Management
Division



INDEX

Asset #	Asset Name	Page
001	Engineering Building	7-5
003	Archaeology Building	7-19
005	Horticulture Building	7-33
006	Saskatchewan Hall	7-43
007	Administration Building	7-61
008	Qu'Appelle Hall	7-71
009	Physics Building	7-87
013	Thorvaldson Building	7-109
021	President's Residence	7-131
025	Observatory	7-147
027	Poultry Science Building	7-159
031	Kirk Hall	7-171
035	Williams Building	7-185
039	Little Stone School	7-199
041	University Club	7-211
048	Dental Clinic	7-223
049	Health Sciences Building	7-049
051	Memorial Union Building	7-249
053	Murray Building	7-263
054	Peter MacKinnon Building	7-279
060-062	Law & Commerce Complex	7-297
061	Arts Complex	7-315
064	John Mitchell Building	7-329
076	Seed Barn	7-343
337	Stone Barn	7-353
346	Feed Elevator	7-367
644	Memorial Gates	7-379
647	Diefenbaker's Gravesite	7-389
932	St. Andrew's College - Affiliated College	7-397
933	Rugby Chapel	7-419
934	St. Thomas More College - Federated College	7-431
935	College of Emmanuel and St. Chad	7-451
936	Emmanuel and St. Chad Chapel	7-467
938-40	Lutheran Seminary - Affiliated College	7-479
	Ernest Lindner Studio	7-497
	'Gus' Kenderdine Studio	7-509
	Devil's Dip	7-519
	The Bowl	7-527
	Palliser Garden	7-535
	Voyageur Place	7--543

001

Engineering Building

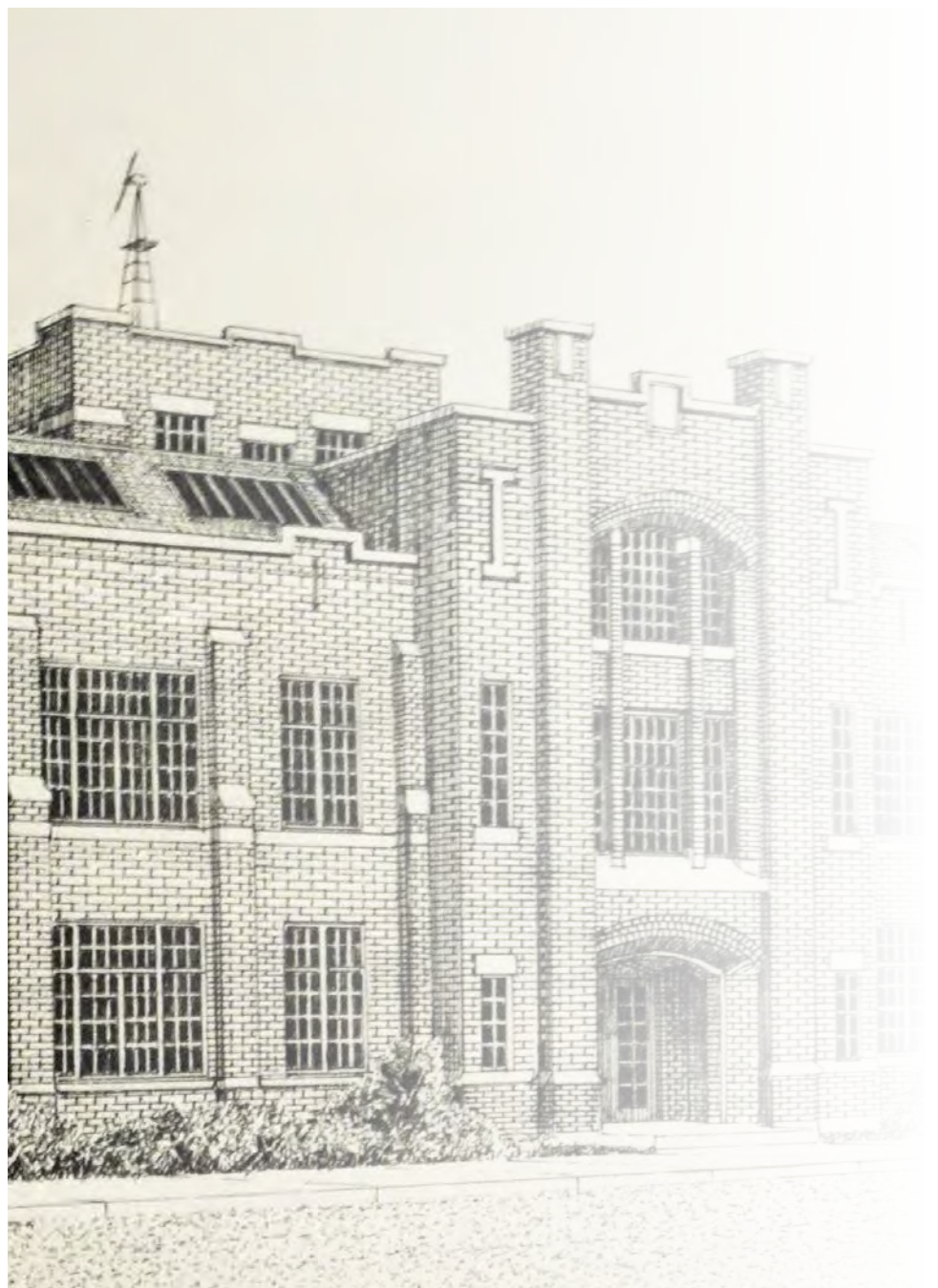

001

Engineering Building

Alternate Names

Farm Machinery Building
Agriculture Laboratory
Agriculture Engineering Building
Old Engineering Building

Architect(s)

David R. Brown and Hugh Vallance, Brown and Vallance Architects, Montreal
G.J.K. Verbeke, Saskatoon

Builders

Bennett and White Construction
W.C. Wells Construction

Construction Dates

1910-1912, additions in 1920, 1923, reconstruction 1925

Recognition

University of Saskatchewan 'B' Listed



Figure 1. The ruin of the Engineering Building after the fire of 1925. The photograph is dated March 13, 1925. Photo A-364, retrieved from <http://sain.scaa.sk.ca/items/index.php/engineering-building-fire;rad>.

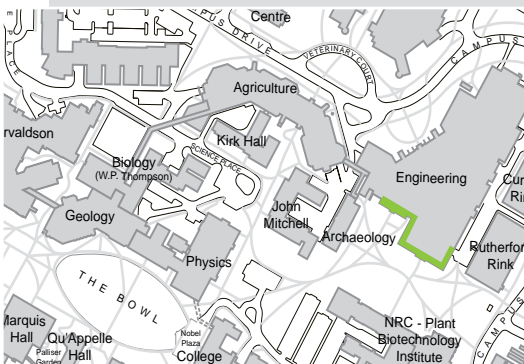

Figure 2. A plan view showing the location of the surviving portion of the 1925 Engineering Building in relation to the current building. The area shaded in green is discussed in this report.

1. Statement of Significance

The Engineering Building was originally built between 1910 and 1912 to house the Agricultural Engineering Department. It was built in the Collegiate Gothic style, similar to the rest of the campus, but in red brick rather than in 'greystone.' It was the first University of Saskatchewan building completed, and the structure was added to in 1913 and 1923 before fire devastated it on March 13, 1925. Figure 1 shows the extent of damage. The building was reconstructed in 1925, and has been added to many times since then. The age of the building, as well as the existence of some remaining original architectural elements and surviving portions of the reconstructed building give parts of the Engineering Building heritage value. In particular, the brick exterior elevations on the southern portion of the building, which date from 1925, are important heritage elements in excellent condition.



Figure 3. The Engineering Building, 1912. Photo A-404, retrieved from University of Saskatchewan Archives.

Following the fire, reconstruction began immediately. The bricks and foundation of the original building were recovered and used in the reconstruction. The Engineering Building had been built originally for \$296,000, a sum for which the university found they had been underinsured. The burning of \$57,000 worth of equipment intensified the problem. With insurance only providing \$114,000, reconstruction required all of the university's available resources at the time. The undertaking led to the postponement of many other projects such as the much anticipated Arts Building. The pressing need to rebuild is evidence of the importance of this building to the university at that time. Figure 2 shows the approximate location of the remaining portions of the 1925 reconstruction in relation to the current plan. The reconstructed building dating from 1925, including surviving elements of the original construction of 1910-12, is the focus of this report.

The Engineering Building's floors are referred to as basement, ground floor, first floor etc.

2. Character - Defining Elements

2.1 Materials

The oldest portions of the building have exterior walls of red-brown brick with Indiana limestone accents. From the outset, brick was used to denote service buildings at the University of Saskatchewan. For example, the Livestock Pavilion and the Power House were both built in brick. This material categorization defined the character of engineering at the time; it was viewed as a service discipline.



Figure 4. New aluminum framed double glazed windows have been fitted over the interior of the original windows.



Figure 5. Brick and sandstone walls. Painted steel window frames.



Figure 6. Roof materials: slate tiles for sloped portions and membrane roofing for flat portions.



Figure 7. A decorated interior staircase with oak banisters, steel and iron balustrades, terrazo treads and steel risers.

The exterior walls feature extensive glazing, consisting of single-glazed windows in rolled steel frames. The window frames are original to the 1925 reconstruction, and are in excellent condition. They have been covered on the interior by double-glazed aluminum-framed inserts, to improve their thermal performance (Figure 3). The exterior brick walls and steel-framed windows on the southern portion of the building are important heritage elements with excellent commemorative integrity.

Window sills, decorative string courses and crenellation are all built in Indiana limestone (Figure 4). (For further information on building stones used at the U of S, refer to [‘Appendix: Stone.’](#)) The roofing materials - slate tile with copper flashings - are character-defining elements that link the Engineering Building to other campus buildings. Flat roofs, not visible from the exterior of the building, were originally roofed with tar and gravel, which has since been replaced with a membrane roofing system (Figure 5). Windows were framed in rolled steel with steel hardware. The threshold to the southwest entrance to the building is granite, another material characteristic of early University of Saskatchewan buildings.

The interior of the building now features virtually no material elements dating from 1925 or earlier. The 1912

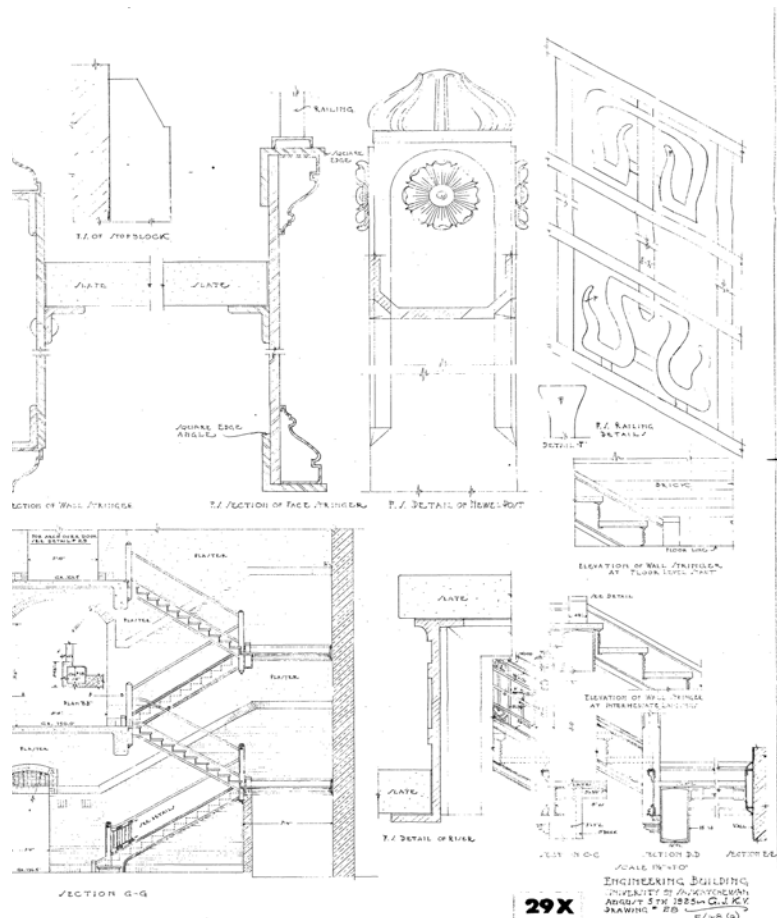

Figure 8. A drawing of the staircase details for the 1925 reconstruction of the Engineering Building. Retrieved from Facilities Management Division Asset System Records, File E-108-T.

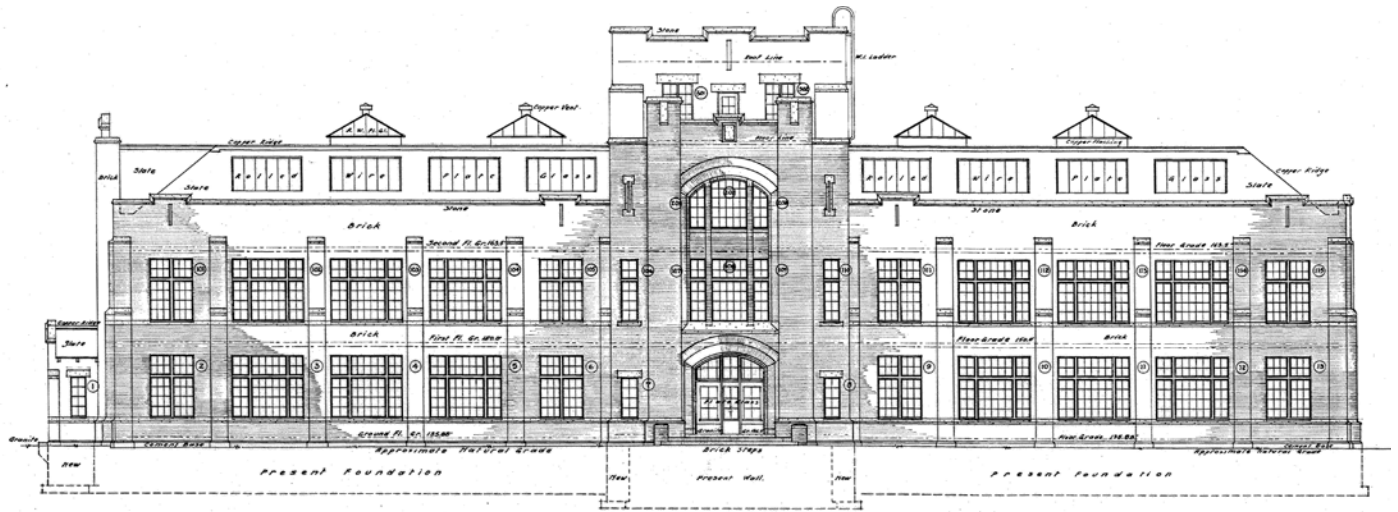

Figure 9. South elevation of the 1925 Engineering Building. Retrieved from Facilities Management Division Asset Record System, File E-5-T.

building had wooden walls and floors. Interior photographs of the original building also show some walls of plaster with brick wainscoting. The restoration of the building following the fire saw the installation of ceramic tile walls and concrete floors. These materials were almost completely removed during a major expansion of the building between 1977 and 1983. All original interior doors and frames have been replaced by steel doors and frames.

The staircase shown in Figure 7 is one of the few character-defining elements dating from the reconstruction of 1925. This staircase features oak banisters and a balustrade of steel and iron. These materials are seen on staircases in numerous early university buildings and are important character-defining elements. The staircase itself is in a reasonably good state of commemorative integrity with few modifications. Treads, which were originally slate, have been replaced by terrazzo. However, the original stairwell is largely obscured by paint, coatings and replacement materials. Figure 8 shows the 1925 drawings of the staircase.

Notably, some of the materials of the original structure that was destroyed by fire in 1925 were preserved. Some of the brick that makes up the reconstructed portion of the building was salvaged from the fire. The concrete foundation of the original building was also re-used, with the newer building built directly on top of the original base. Even some old windows were reused.

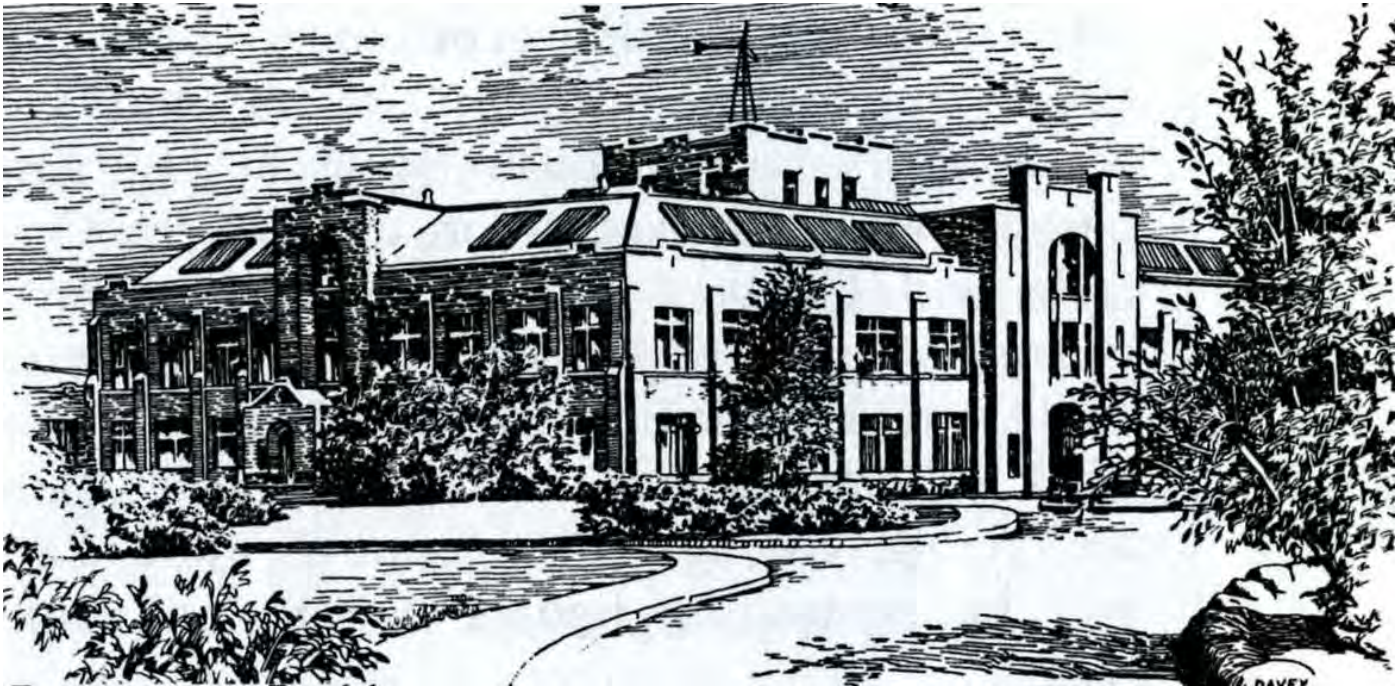

Figure 10. The form of the Engineering Building ca. 1930. Retrieved from Macdonald, R. H. (1982). *Thorough: An Illustrated History of the College of Engineering, University of Saskatchewan, 1912-1918*.

2.2 Form

The form of the Engineering Building has been altered to a great degree by later additions. Elements of the 1925 form are still discernible. The southern facade is still visible and the reconstruction of the building in 1925 was similar in form and appearance to the 1912 original (Figure 9). The forms of the both the 1912 and 1925 buildings were 2-storey brick masses with a 3rd attic storey under a pitched slate roof. Figure 10 shows the form of the building, after reconstruction. The 3rd story skylights were added in 1925.

Since then, several additions have been made to the building. In 1939 the west wing of the new building was extended northward to house the Mechanical Engineering laboratories and the Welding Shop. Further additions were completed in 1941, 1946 and 1963. Between 1977 and 1983 the entire building was overhauled and redesigned. These changes encompassed the replacement of the original portion of the single storey west wing and the construction of additions and renovations in what remained of the original building.

Through all of these works, the scale has been limited to three floors; however, the original shape of the building has been subsumed by the additions. Figure 11 shows the current form of the Engineering building in plan. Aside from their effect on the original form, the additions are beyond the scope of this report.



Figure 11. An arched entry.

2.3 Style

With its arched openings, slate tile roofing and crenellation, the Engineering Building can be classified as Collegiate Gothic in style. However, the building was designed in a simplified version of the style, and features fewer Collegiate Gothic elements than many of its main campus counterparts. The southern facade of the 1925 building is divided up into a number of structural bays separated by brick piers. Large steel-framed windows are a prominent feature of the elevations. Principle windows and entrances are accentuated by shallow brick arches (Figure 11).

Also visible on the façade are narrow decorative slots styled as archer windows. Crenellation along the roofline follows the rhythm of the structural bays. Drainage spouts are embellished in Indiana Limestone as shown in Figure 13. Limestone is also used to detail decorative string courses.

The interior of the surviving 1925 structure has virtually no original Collegiate Gothic elements. Arched exterior windows are visible from inside the stairwell; Figure 14 shows one such arched window. A staircase, seen in Figure 7, features a flower motif on its cast iron balustrade.

2.4 Location

Set outside the immediate grouping of buildings around ‘[The Bowl](#)’, the Engineering Building differentiated itself as a brick building on the outskirts of the campus. This carefully considered location reveals the prevailing view of engineering at the time as a service profession. The Engineering Building was not depicted in the 1909 Campus Plan, but its location, shown in Figure 12, is original to the initial construction in 1912. Its location, outside, but near The Bowl, remains a character-defining element.

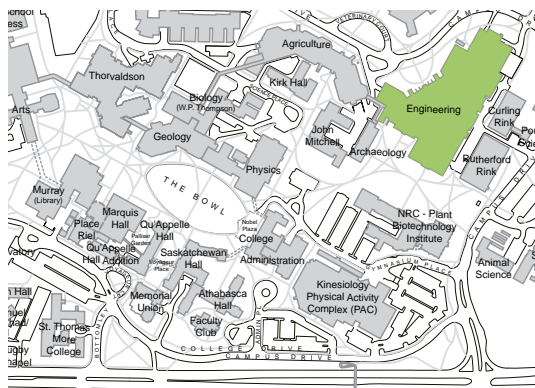

Figure 12. The current form and location of the Engineering Building in plan are indicated in green on this contemporary campus map.

The main campus has grown to surround the Engineering Building with other academic buildings such as the Agriculture Building and the Veterinary Medicine College. These additions to the area have integrated the Engineering Building with the core of the university campus.



Figure 13. The Collegiate Gothic elements of the Engineering Building include: arches, crenellation, slate tile roofing, embellished drainage spouts and decorative archer slots.



Figure 14. Arched window.

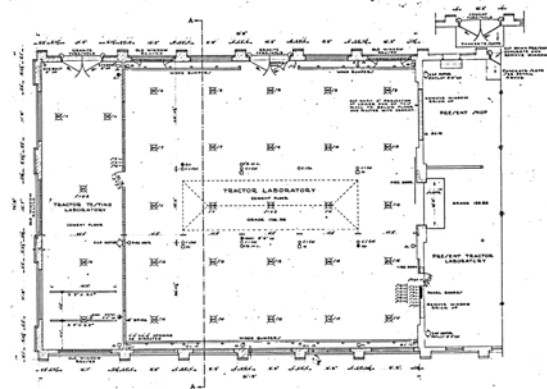

Figure 15. Plans for the extension of the tractor lab in 1940. Retrieved from Facilities Management Division Asset Record System, File E-55-T.



Figure 17. The concrete foundation and footings that withstood the fire of 1925 were reused in the reconstruction of the Engineering Building.



Figure 18. The Engineering Building being used for classes. Pictured here is the 'famous class of '25'. Retrieved from Macdonald, R. H. (1982). *Thorough: An Illustrated History of the College of Engineering, University of Saskatchewan, 1912-1982.*

2.5 Spatial Configuration

The Engineering Building was originally designed to hold machinery and plant science exhibits for classes, among other functions. It was therefore characterized by a large, open floor plan with rooms substantial enough to hold the large equipment of the period. In 1913, a 72' by 122' addition was constructed, including a test lab for building materials, a civil engineering lecture room, a classroom, a farm mechanics workroom and a third floor for the study of farm machinery. In 1917 the building was again extended to house a tractor lab. Figure 15 shows the floor plan for this extension.



Figure 16. A photograph of the construction of the Engineering Building in 1910. Photo A-328, retrieved from http://scaa.sk.ca/gallery/uofs_buildings/

Today, the building houses laboratories more compactly than in the past. Hallways connect these labs which are still housed in relatively large rooms as the need for large equipment and machinery has prevailed.

Updates to the building have changed the experience of the visitor. For example, the orientation of the building has been reversed. Originally, the main entrance faced south towards the main campus. The new main entrance faces north towards Campus Drive. The original main entrance has become a secondary entrance opening into a corridor serving laboratories. As the building floor plate has deepened, spaces that were formerly primarily lit by daylight are now artificially lit.

2.6 Systems

The original Engineering Building was supported by a wooden post and beam structure. Figure 16 shows this structural system being erected. When the building was reconstructed in 1925, the wooden structure was replaced with a steel frame. Below grade a concrete foundation supported the building. The concrete footings survived the 1925 fire and were reused in the reconstruction. These surviving foundations are a character-defining element of heritage significance. Figure 17 illustrates an original concrete column located in the basement of the building. In both their 1912 and 1925 iterations, the exterior walls of the building were load bearing structural elements.

2.7 Uses

The building was originally built to house the Agricultural Engineering Department. With this in mind Brown and Vallance Architects designed the lower floor for blacksmithing, cement work, engine construction and heavy farm machinery. The second floor held a lecture room, woodworking, carpentry, pumps and farm equipment. The third floor was a drafting room with light farm equipment. In 1917, the second wing brought a test lab for building materials, a civil engineering lecture room, a classroom, a farm mechanics works room and a tractor lab. Civil and Hydraulic engineering were added in a 1921 addition. Figure 18 shows a classroom lecture in progress, and Figure 19 shows the blacksmith's lab in which hands-on learning took place.

The Engineering Building held classes in field husbandry for many years and housed numerous plant exhibits. The fire in 1925 incinerated all of that year's seed stock, and subsequently Field Husbandry was given its own [building](#).



Figure 19. A workshop in the original Engineering Building with anvils and forges standing in rows. Photo A-398 retrieved from http://scaa.sk.ca/gallery/uofs_buildings/



Figure 20. The 'old portion' of the Engineering Building that survived the fire. Photo A-4914 retrieved from http://scaa.sk.ca/gallery/uofs_buildings/



Figure 21. Saskatoon's Broadway Bridge (originally known as the 'Engineers Bridge' under construction in December, 1932. The bridge is a product of early University of Saskatchewan engineering faculty and graduates. Retrieved from http://scaa.usask.ca/gallery/uofs_events/articles/1932.php



Figure 22. The opening ceremony for the Borden Bridge, May 24, 1937. Photo LH-750, retrieved from http://spldatabase.saskatoonlibrary.ca/internet/LHR_RADQuery.htm.

A portion of the original building survived the fire due to its unusual construction. The ceramics lab was built to withstand the heat of the kilns. A fire-proof kiln door and walls lined with fire brick helped to stop this room from succumbing to the fire. The ceramics curriculum was discontinued in the 1950's and the ceramics lab no longer exists. Figure 20 shows the parts of the building that survived the fire.

With the reconstruction of the old portion of the building some new uses were added such as a smoking lounge for students, a new library, reading room, Dean and Assistant Dean's offices, about 15 staff offices, drafting rooms, several lecture rooms, laboratories and postgraduate student offices.

While the specific uses of individual rooms has changed significantly due to the evolving nature of education, the continuous use of the building by the Faculty of Engineering is historically significant.

2.8 Cultural & Chronological Associations

Within the city of Saskatoon, the Engineering Building can be associated with two other structures. During the Great Depression of the 1930's, the first Dean of Engineering, Chalmers Jack McKenzie, took it upon himself to build these structures as 'make work' projects. McKenzie took an interest in city planning and sought to build a bridge between the downtown and Broadway Avenue to prevent the former from becoming a slum. So passionate was he about the project that he ran and was elected Chairman of the City Planning Board in 1928. After winning acceptance for his proposal from City Council, McKenzie took a leave of absence from his duties at the university to lead the project. The Federal Government accepted the project on the basis that it created jobs; all labour had to be hired from the local relief office and no work that could be done by hand was to be carried out by machine in order that employment be maximized (Macdonald, 1982).

McKenzie and four engineering graduates from the previous year made up the engineering staff overseeing the work. During construction of the bridge between December 1931 and November 1932, 1593 men were employed. An additional allowance was made for the concrete bridge to be scoured of all rough spots and remnants of its wooden formwork. "It was indeed a hand rubbed piece of community furniture – it added jobs too." (Macdonald, 1982). Now known as the Broadway Bridge, in its early years it was called the 'Engineers Bridge'. The bridge is shown in Figure 21. In 2012, a plaque was unveiled at the east end of the Broadway Bridge, honouring C.J. MacKenzie and his role in its construction.

Four years later the same team of engineers with some minor staffing adjustments built a second bridge. Perhaps the last substantial reinforced concrete bowstring arch bridge designed and built in Canada, the 'Ceepee' Bridge was another 'make work' project designed to create community jobs. Labour came from the surrounding communities of Borden, Langham and Saskatoon. Later known as the Borden Bridge, it opened in 1937. This Bridge has the longest arch span of any similar design in North America and is shown in Figure 22.

3. Associated Objects

Graduation photographs documenting classes dating as far back as 1914 adorn the walls of the Engineering Building. These photographs are shown in Figure 23. Another item of heritage value related to engineering is a surveyors' instrument and texts displayed within the building (Figure 24).

A plaque in the vestibule of the eastern entrance on the south facade declares the Engineering Building as the first University of Saskatchewan structure completed on campus. The plaque is shown in Figure 25.



Figure 23. Engineering Graduation photos.



Figure 24. Surveyors instrument and texts.



Figure 25. A plaque commemorating the construction of the Engineering Building.

4. Supporting Documents

Author Unknown. (2011). *College of Engineering: History*. Retrieved from <http://www.engr.usask.ca/aboutus/history.php>

University of Saskatchewan Archives. (Retrieved 2011). *Events in the History of the University of Saskatchewan 1925: Fire Destroys the Engineering Building*. Retrieved from http://scaa.usask.ca/gallery/uofs_events/articles/1925.php

University of Saskatchewan Archives. (Retrieved 2013). *Events in the History of the University of Saskatchewan 1932: Broadway Bridge opens, designed by Dean of Engineering*. Retrieved from http://scaa.usask.ca/gallery/uofs_events/articles/1932.php

Facilities Management Division (2011). Asset Resource Database [Data File]. Retrieved from \\usask\fmddfs\files\iis\IIS_Public\ARS.

Fast, B. (2012). *E is for Engineering: 100 Years*. Saskatoon: College of Engineering.

Hayes, P. (October 18, 1996). 1925 Engineering Building Fire. *On Campus News*. Retrieved from http://library.usask.ca/archives/campus-history/ocn/ocn_18oct1996-fire.php

Herrington, R. (March 1, 2008). *Statement of Heritage Significance Borden (Ceepee) Bridge*. Retrieved from <http://www.tpcs.gov.sk.ca/BordenBridge>

Macdonald, R. H. (1982). *Thorough: An Illustrated History of the College of Engineering, University of Saskatchewan, 1912-1982*. Saskatoon: College of Engineering.

University of Saskatchewan Archives. (Retrieved 2011). *Campus Buildings: Engineering Building*. Retrieved from http://scaa.sk.ca/gallery/uofs_buildings/.

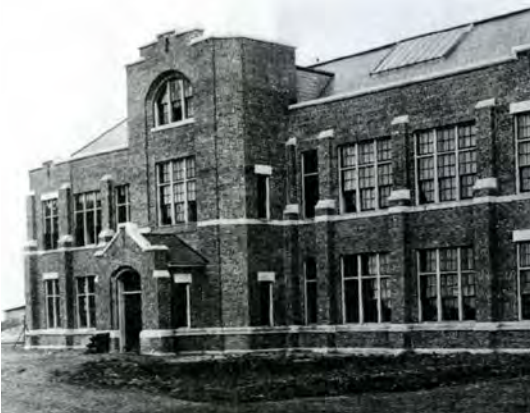

5. Summary of Character - Defining Elements

Materials

- red-brown brick
- Indiana limestone decoration
- single glazed windows
- rolled steel
- slate roof tiles
- copper flashings
- granite
- oak banisters
- steel and iron balustrade
- concrete

Form

- scale of three stories
- south facade

Style

- structural bays separated by piers
- large windows
- arches
- archer slots
- crenellation
- ornamented drainage spouts (scuppers)
- string courses
- flower motif on balustrade
- slate tile roof

Location

- outside of The Bowl between
- academic and service spheres of the university

Spatial Configuration

- large, open plan rooms

Systems

- concrete footings which survived fire

Use(s)

- engineering (blacksmithing, cement work, engine construction, heavy farm machinery, lecture rooms, woodworking carpentry, drafting, material testing, ceramics, etc)
- field husbandry

Cultural & Chronological Associations

- Broadway Bridge
- 'CeePee' or Borden Bridge



003

Archaeology Building

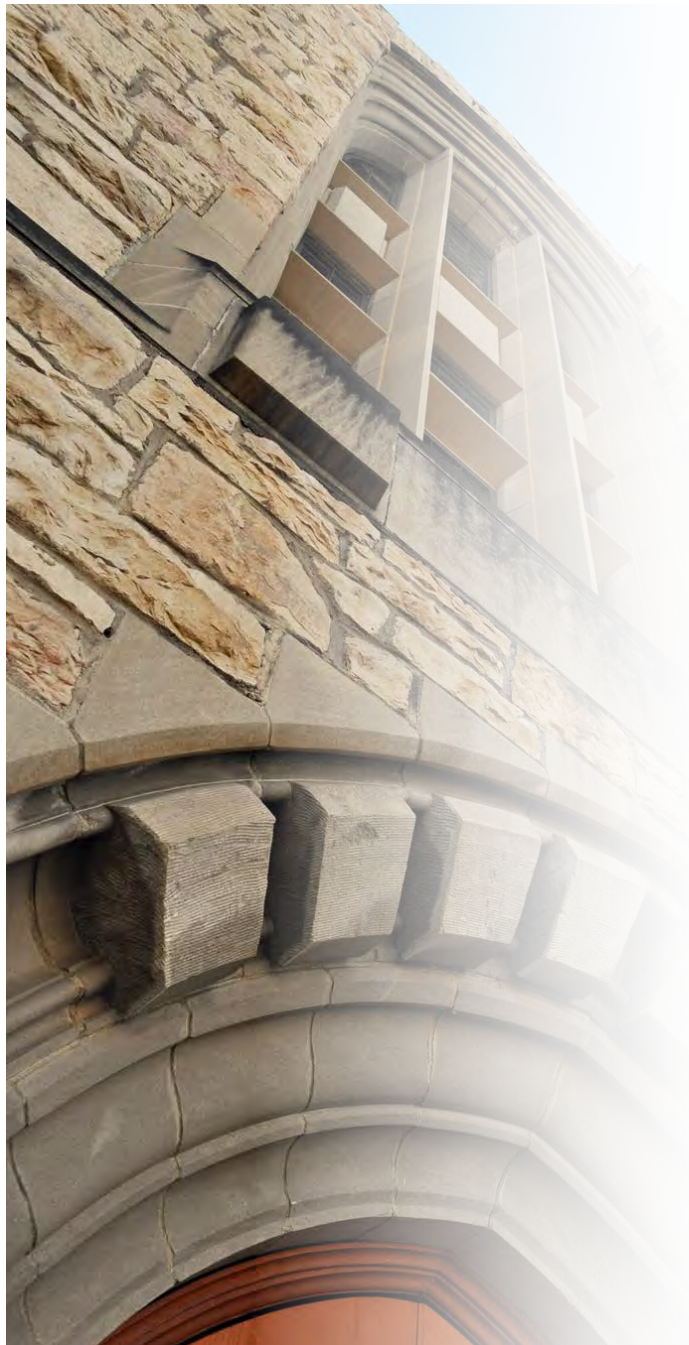

003

Archaeology Building

Alternate Names

Field Husbandry Building

Crop Science Building

Architect(s)

David R. Brown, Brown and Vallance Architects, Montreal

Builders

Smith Brothers & Wilson, General Contractors

Construction Dates

1928-1929, 1937

Recognition

University of Saskatchewan 'A' Listed

1. Statement of Significance

Located between the [Engineering Building](#) and 'The Bowl' and facing the landscaped courtyard known as the 'Engineering Bowl', the Archaeology Building is a handsome stone building in the Collegiate Gothic style. The building incorporates an original portion built in 1929 and an addition built in 1937. Its initial cost in 1929 was \$260,000. In 1973 a small stair tower was built on the north end of the building, in 1987 a new elevator tower was added, and in 1990, a link was built between the Archaeology Building and the new Agriculture Building. The stair tower and link are beyond the scope of this report; this assessment is concerned only with the portions of the building constructed in 1929 and 1937.

The building holds significant heritage value in its history as the home of the department of Field Husbandry, and in its material, formal and stylistic character. This heritage value is amplified by the building's excellent state of preservation and commemorative integrity.



Figure 1. Top to Bottom: 'greystone', Indiana limestone, granite. A copper drainage pipe is pictured to the right.



Figure 2. Archaeology Building after expansion ca. 1950's. Photo A-282 retrieved from http://scaa.sk.ca/gallery/uofs_buildings/

Note: The Archaeology Building is configured with floors numbered Basement, Ground Floor, First Floor and Attic. This report follows the same convention.

2. Character - Defining Elements

2.1 Materials

Constructed principally of 'greystone' with Indiana or Bedford limestone trim, the exterior materials of the Archaeology Building are characteristic of the early buildings of the University of Saskatchewan campus. (For further information on building stones used at the U of S, refer to ['Appendix: Stone.'](#)) The original roofing material for the sloped roofs is called up on the drawings as 'Barrett Mineral Surfaced Shingle', in green; an early asphalt shingle. The original material is no longer in place; however, in this instance the current asphalt shingles are not historically out of character. There is a base course of granite where the building meets grade. Copper gutters and downspouts are carefully placed so as to be inconspicuous among the stone facades. Figure 1 shows the principle stone materials and the copper drainage. The facades are punctuated by steel-framed windows.

The original exterior and vestibule doors at the two main entrances were constructed of quartersawn oak with glass panels (Figure 3). The vestibule doors and both sets of door frames and transoms remain, but the exterior doors have been replaced with new doors which do not match the original design. Interior doors are typically of stained douglas fir, and feature wood-framed glass transoms. The original door and transom glass has a distinctive striated texture (Figure 4). On the ground floor, the door transoms are set into brick arches.



Figure 3. Quartersawn oak vestibule door with glazed panels. Brick and plaster clad wall, cast iron radiator.

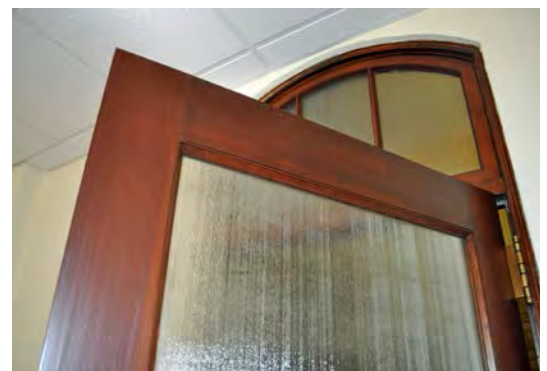

Figure 4. Textured door and transom glazing.



Figure 5. Black slate stair treads and painted clay tile flooring.

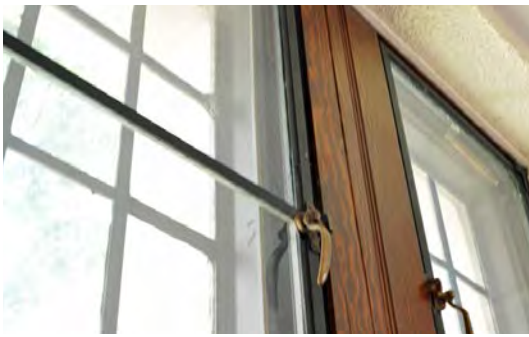

Figure 6. Steel framed windows, wood casings and brass hardware.



Figure 7. Exposed structural steel.

The entrance vestibules feature red clay tile flooring. This material is also found in the hallways adjacent to the stairs; however, in these locations it has been painted. Stair treads and landings are of black slate, a character-defining element distinct from the slate used in other U of S buildings of this period, which is typically green in colour. The slate stair treads are worn from decades of use (Figure 5). The stairs have painted steel and cast iron balustrades and stringers, with oak handrails. Cast iron can also be found throughout the building in the form of painted radiators.

In the basement, exterior walls are clad on the interior in brick, which has typically been painted. The interior walls of the upper floors are clad in a wainscoting of unpainted brick, with painted plaster ceilings (Figure 3). Some of the exterior walls of the attic and basement levels are faced in painted brick on their interior surface.

The steel framed casement windows consist of an interior and exterior set. The exterior windows are divided by mullions into multiple panes, while two larger panes of glass make up the interior window. Window sills are either in black slate or wood which has been painted black. Both doors and windows have brass hardware. The larger windows have wooden surrounds on the interior.

The materials of this building generally exist in an excellent state of commemorative integrity, with a few exceptions, such as the exterior doors, and a few transoms which have been replaced. In all of the classrooms and offices the ceiling has been hidden by the addition of dropped ceiling tiles.

The attic and basement are both treated as ancillary spaces, with more utilitarian finish materials. On both levels flooring consists of painted concrete. The walls are plaster or painted brick, the ceilings are generally a rough-textured plaster, and in some instances have been concealed with dropped tile. In the attic, only a few original wooden doors exist; the rest are pressed steel doors of no heritage significance. Some of the skylights have been replaced, others have had their wooden frames painted obscuring the original material. A character-defining material of the attic is the steel forming the exposed trusses shown in Figure 7. (See section 2.6).



Figure 8. Archaeology Building in 1929, shortly after construction. Photo A-276, retrieved from http://scaa.sk.ca/gallery/uofs_buildings/



Figure 9. Archaeology Building in 1958-1959, after its expansion. Photo A-284, retrieved from <http://sain.scaa.sk.ca/items/index.php/exterior-of-crop-science-building-7;rad>

2.2 Form

The Archaeology Building consists of a single mass, rectangular in plan. Figures 8 and 9 show the building as it was before and after the 1937 expansion. The long and narrow floor plans of this building are characteristic of early University of Saskatchewan buildings. The Archaeology Building consists of two storeys above ground, an attic, and a half exposed basement. At three storeys in height overall, the Archaeology Building is sympathetic to the pedestrian environment of the campus core. The form of this building maintains a high degree of commemorative integrity; the link added to its north side is relatively discreet, and the form of the original building and its 1937 addition are both readily apparent.



Figure 10. Arched ground floor windows and string courses.

2.3 Style

The architectural style of the Archaeology Building is Collegiate Gothic. As shown in Figure 10, the ground level of the building features limestone door and window surrounds in the form of both pointed and standard arches. The four corners of the building are marked with prominent stone buttresses and quoined stonework. Cut stone string courses decorate the stone walls at the window sill levels. Narrow limestone archer slots adorn the low parapet roofline. All of these features are character-defining elements.

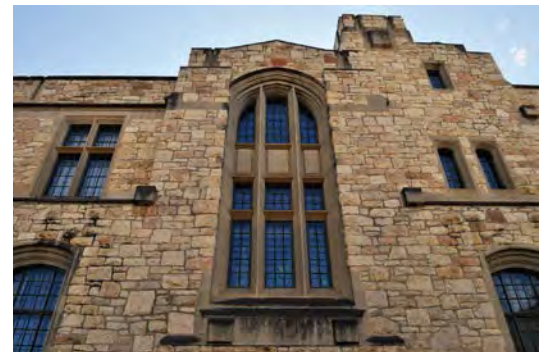

Figure 11. The west facade: archer slots line the parapet roof, a tower rises to the right of a double height Gothic window.



Figure 12. The main staircase.

The building's most commanding façade is illustrated in Figure 11, although it is now somewhat obscured by later construction. On this west face, the location of the main staircase is expressed with a prominent double-height window with a pointed arch and mid height spandrels. This window and an adjacent decorative element referencing a Norman tower, both form part of an asymmetrically composed elevation, and are important character-defining elements. The central staircase offers a view out of this window from each of its landings as shown in Figure 12. On the interior, the arch of this window is framed in a shallow vault.

On both lengths of its façade, the Archaeology Building features blank stone blocks around its entrances. These blocks were originally intended to be decorated with cut stone ornamentation. Shields and reliefs were also intended for the blank spandrels or stone panels that accompany the windows. These finishing touches were never carried out and the stone 'blanks' are now character-defining elements in their own right. Figure 13 shows the architect's original specifications for carved stone decoration around the west entrance, and the incomplete work is illustrated in Figure 14.



Figure 14. Unadorned stone blocks above the west entrance where cut stone ornamentation was originally intended. Photo taken ca. 1960. Photo A-288, retrieved from http://scaa.sk.ca/gallery/uofs_buildings/

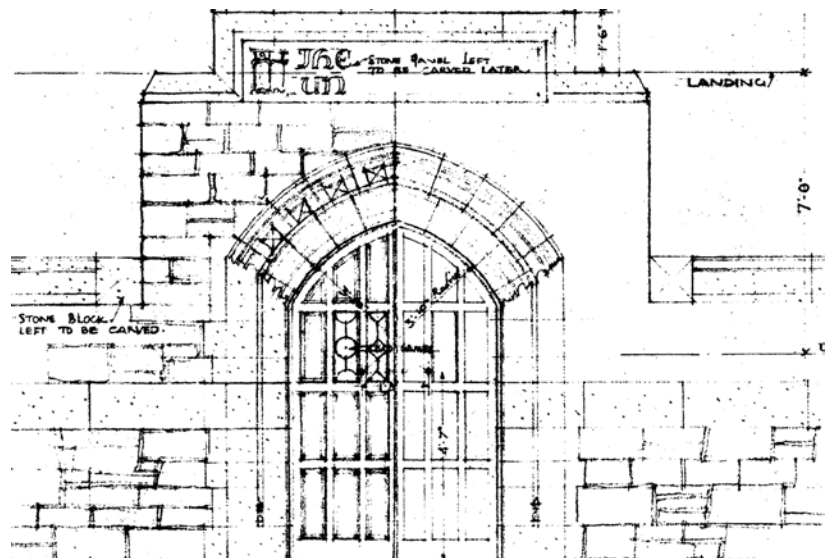

Figure 13. Elevation of the west entrance. Retrieved from Facilities Management Division Asset Record System, File CB-21-T.

The public spaces of the building have received particular attention to detail and help define the character of the building. Four arches, with corbels at their ends, frame the area where the two principle entrances intersect with the central staircase (Figure 15). This character-defining element is repeated on the ground and first floors. The staircase, shown in Figure 12, has several ornamental features, including cast-iron newel posts and slate treads. The main corridor is defined by doorways featuring arched transoms that are framed in brick. These arched brick surrounds have limestone keystones at their crowns. Figure 16 shows an arched transom above a set of doors in one of the vestibules. The repetition of these arched openings throughout the interior is an important element in defining the character of the building. The ground floor also features arched windows. The arches are visible from the exterior; however, dropped ceiling tiles have been applied in many locations, obscuring the arches from view on the interior.

2.4 Location

Originally constructed as the Field Husbandry Building, the Archaeology Building does not appear on the 1909 Campus Plan, but was located immediately to the west of the original [Engineering Building](#). It appears to have been placed with the intention of defining the western end of the courtyard that is now known as the 'Engineering Bowl'. As Figure 18 shows, it is orientated in a linear fashion along a roughly north-south axis, with entrances from the east and west. Notably, the building's more active west façade now faces onto a parking lot and loading area, somewhat compromising its commemorative integrity (Figure 19). At the time of its construction, this elevation addressed an area of open fields.



Figure 19. The west side of the building faces onto a parking lot and loading dock.



Figure 15. Four arches crown the space at the foot of the main stair.

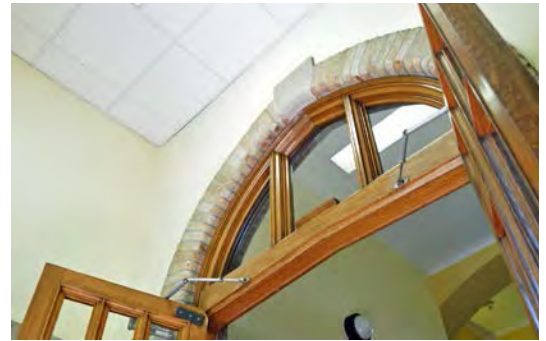

Figure 16. Transom in the form of a pointed arch, inset into a brick arch, with keystone.



Figure 17. Window detailing.



Figure 18. The location of the Archaeology Building is indicated in green on this contemporary campus map.

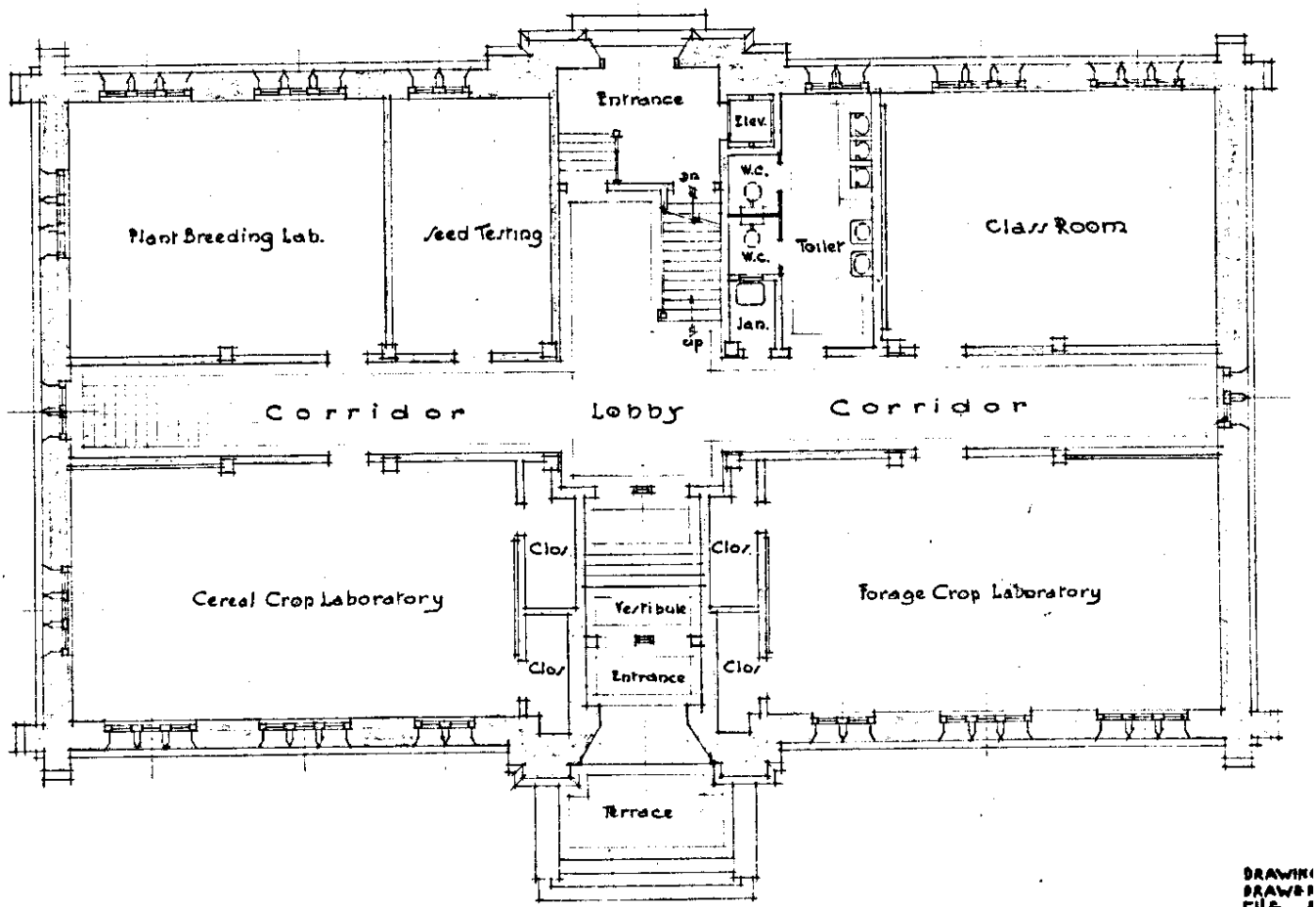

Figure 20. The ground floor plan of the original Field Husbandry (now Archaeology) Building. Retrieved from Facilities Management Division Asset Record System, File CB-15-T.

2.5 Spatial Configuration

The general spatial configuration of the Archaeology Building is typical of the configuration of other academic buildings built on campus prior to the Second World War. On the ground and first floors, it features a simple floor plan with central double loaded corridors providing access to a series of discreet rooms - offices, classrooms and laboratories - on either side. Figure 20 shows the original layout of the ground floor. Notably, a small elevator was provided for and is visible in the drawings. The shaft still exists, but the elevator is no longer in use. (See Section 2.6 Systems). The original layout on these floors has been generally maintained. The original plans show the basement and attic as having open floor plans, as is shown in Figure 21. Both floors have since been divided into separate rooms, albeit to different degrees. The basement has been arranged around a double loaded corridor. The attic has also been divided into separate rooms; however, a large open area has been maintained. Figure 22 shows the shape of the attic in section.

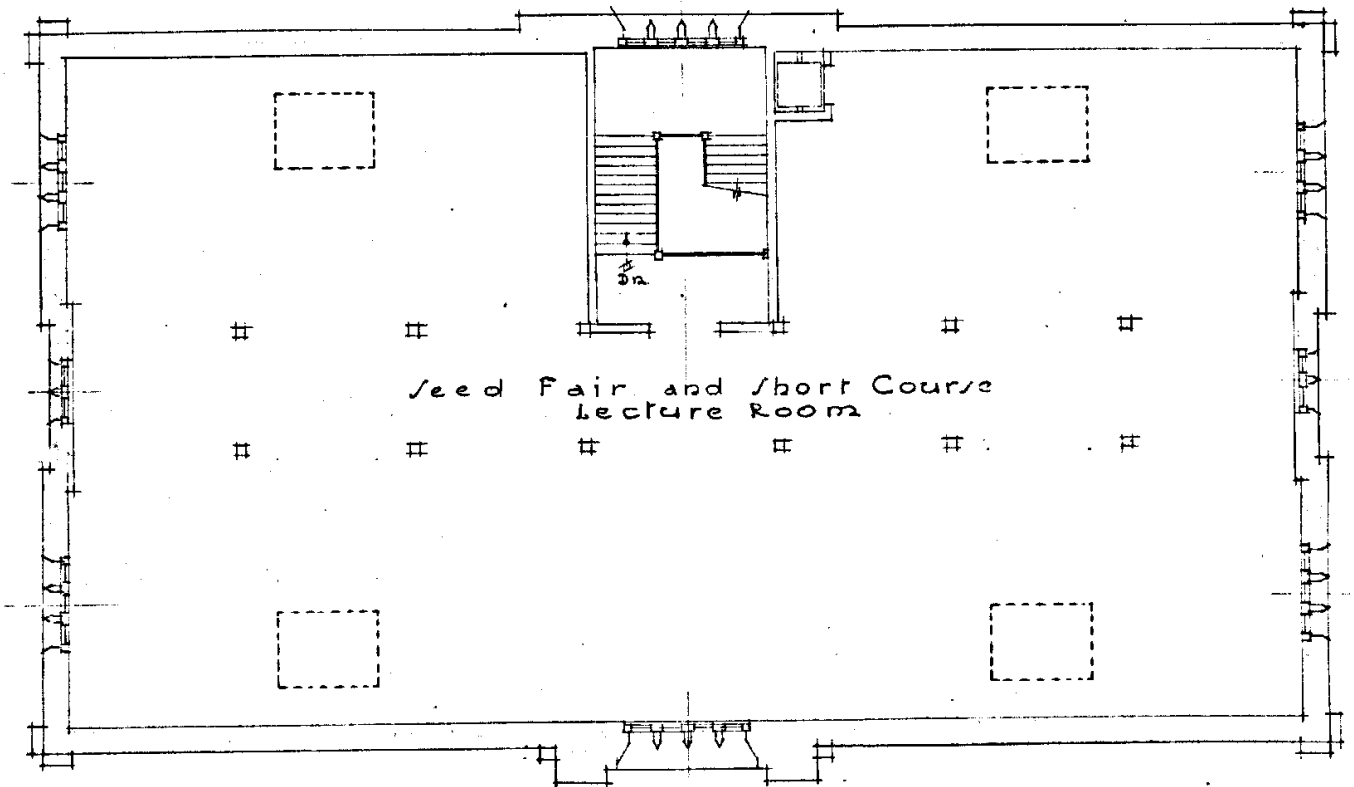

Figure 21. The attic floor plan of the original Field Husbandry (now Archaeology) Building. Retrieved from Facilities Management Division Asset Record System, File CB-17-T.

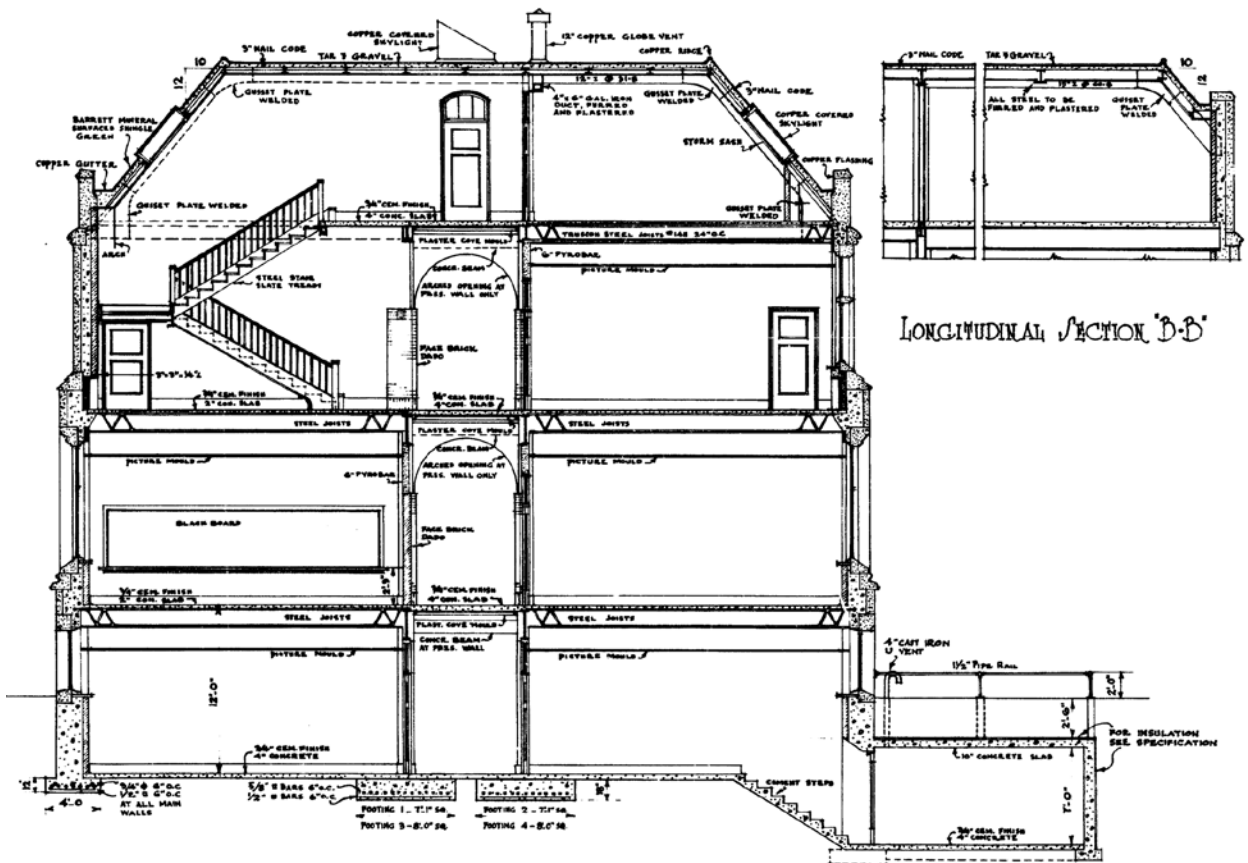

Figure 22. Section through the Field Husbandry (now Archaeology) Building. Retrieved from Facilities Management Division Asset Record System, File CB-51-T.



Figure 23. Attic skylight.



Figure 24. Arched steel truss in the attic.



Figure 25. Seed testing in the Field Husbandry Building ca. 1947. Photo A-8566, retrieved from University of Saskatchewan Archives.



Figure 26. Anatomy lab in the top floor of the Field Husbandry (now Archaeology) Building. Retrieved from Buchan, D.J., Greenhouse to Medical Centre Saskatchewan's Medical School 1926-78.

Eight years after its initial form was completed, the Archaeology Building (Field Husbandry Building at the time) was extended. The building's double loaded corridors were extended and more rooms were added. In 1973 and 1987, further changes to the spatial configuration of the building were made with the addition of a stair tower and elevator shaft to the north end, and subsequently a link to the [Engineering](#) and Agriculture Buildings. Despite these changes, the interior configuration of the building has been maintained to a very high level of commemorative integrity.

2.6 Systems

From the original architectural drawings, the structure of the Archeology Building appears to be a hybrid system. The exterior walls are load-bearing concrete, faced in stone on their exterior face and brick on their interior face. On the interior of the building, a structural steel frame encased in cast-in-place concrete supports the floors. Floors are typically cast-in-place concrete supported on open web steel joists. The surface of the concrete is painted and used as a finish material in many locations. Parts of the roof structure are visible in the attic storey, and consist of a series of arched steel trusses (Figure 24). The drawings indicate cast-in-place concrete foundation walls and reinforced concrete footings.

The building was the first on campus to be designed with an elevator. The elevator has not been maintained; however, its shaft still exists. The elevator was located directly adjacent to the staircase on its south side.

2.7 Use(s), Cultural & Chronological Associations

The Archaeology Building was initially constructed as the home of the Field Husbandry Department. The Field Husbandry Building, as it was first known, held offices, classrooms and separate labs for forage crops, cereals and plant breeding. A room for seed testing, as illustrated in Figure 25, was located on the ground floor and an exhibit library was located on the first floor. The basement served as a seed work room and the attic was used as a seed fair and short courses lecture room.

The 1937 expansion of the building brought new uses. The School of Medical Science occupied the building from 1937 until 1950. This brought entomology uses to the basement, a physiology lab, optical lab and preparation room to the first floor and a histology lab and dissecting room to the attic. Figure 26 shows the building being used for the study of medicine.

An undated drawing, presumably from the Second World War, indicates an office of the RCAF was located in the building.

In 1997 the Department of Anthropology and Archaeology moved into the building and the building was renamed accordingly. In 2002, Anthropology amalgamated with the Department of Religious Studies and relocated; the building was renamed the Archaeology Building in 2005. Since then, a single Department of Archaeology and Anthropology has been re-established, but the building name has not been changed. In its current use the building houses offices, labs, an archaeology library and lounge spaces. In the attic, spaces for art students are allocated.

3. Associated Objects

A chalkboard is still existing in a ground floor classroom. The chalkboard is of heritage value for its materials and age. (See also Section 2.1 Materials, and Figure 27).

The building contains a few pieces of furniture of possible heritage interest which are associated with its current use as the Archaeology Building. Several oak display cabinets appear to be roughly contemporary with the age of the building, although their dates of manufacture are unknown. A small plaque on each of these indicates that they were donated by 'Charles A. Murphy, Jeweler', of Saskatoon in 1968, but they appear to be older than this date. They also feature the words 'Museum of Anthropology and Archaeology' on brass plates. One of these cases is shown in Figure 28.

4. Supporting Documents

Buchan, D.J. (1983). *Greenhouse to Medical Centre: Saskatchewan's Medical School 1926-78*. Saskatoon: University of Saskatchewan.

Facilities Management Division (2011). Asset Record System [Data File]. Retrieved from \\usask\fmddfs\files\iis\IIS_Public\ARS

Kerr, D. (1980). Building the University of Saskatchewan 1907-1930. *Prairie Forum*, 5(2), 157-181.

University of Saskatchewan Archives. (Retrieved 2011). *Campus Buildings: Field Husbandry > Crop Science > Anthropology & Archaeology Building > Archaeology Building*. Retrieved from http://scaa.sk.ca/gallery/uofs_buildings/



Figure 27. Slate chalkboard in oak frame.



Figure 28. Oak cabinets found in the Archaeology Building.

5. Summary of Character - Defining Elements

Materials

- greystone walls
- granite base course
- Indiana limestone trim and ornamentation
- copper drainage hardware
- brass fixtures
- steel window frames
- cast iron radiators
- steel and cast iron staircase, with black slate treads
- brick walls and wainscoting
- textured door and transom glazing
- black slate floor and chalkboard
- quarter sawn oak and douglas fir doors and surrounds

Form

- single massing
- pedestrian scale

Style

- gothic arched doorways
- arched windows and transoms
- string courses
- piers
- archer slits
- parapet roofline
- double height arched window
- tower
- unfinished stone ornamentation
- plaster and brick interior arches
- arched transoms
- ornamented staircase
- oak and fir window details

Location

- west side of Engineering Bowl

Spatial Configuration

- double loaded corridors
- skylights
- elevator shaft

Systems

- exposed arched steel roof trusses
- shaft for original elevator



Uses(s)

- field husbandry, crop science (offices, labs, classrooms, work rooms)
- medical education (labs, preparation rooms, dissecting rooms)
- anthropology and archaeology research
- medical education

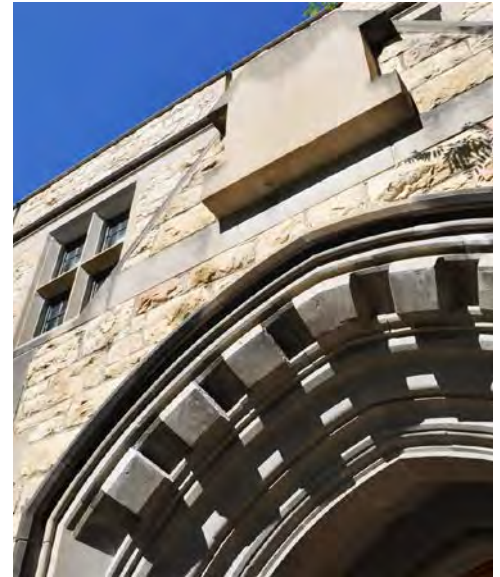

005

Horticulture Building



005

Horticulture Building

Alternate Names
Header Houses

Architect(s)
David R. Brown and Hugh Vallance, Brown and Vallance Architects, Montreal
G.J.K. Verbeke, Architect., Saskatoon

Builders
Unknown

Construction Dates
1916, expanded in 1918 and 1924 - 1926

Recognition
University of Saskatchewan 'B' Listed

1. Statement of Significance

Built in 1916, the Horticulture Building is the former header house for a series of greenhouses, which are now demolished. It holds heritage value due to its age, and as a cultural memory associated with the greenhouses and with the history of agricultural education and research at the University of Saskatchewan. Although built for the purposes of agricultural education and research, the Header Houses also have an association with the College of Medicine; the School of Medical Sciences was located there for its first four years.



Figure 1. A window sill of Indiana limestone set into a 'greystone' wall.



Figure 2. Wood-framed windows in a greystone wall, and exposed rafter ends.



Figure 3. A Tyndall stone threshold.



Figure 4. The Horticulture Building, 1930. The greenhouses are visible on the south side. The back of the photo reads, "Anatomy and Physiology Laboratories." Photo A-11013, retrieved from University of Saskatchewan Archives.

2. Character - Defining Elements

2.1 Materials

The exterior of the remaining Horticulture Building is finished in fieldstone or 'greystone' (Figure 1). Its windows are single-glazed, with removable storms and insect screens. Windows and doors are all framed in painted wood (Figure 2). Window sills are made from Indiana limestone, also visible in Figure 1. (For further information on building stones used at the U of S, refer to [Appendix: Stone](#).)

Two metal doors on the west side were later additions. Some of the thresholds under doorways are made from Tyndall stone, as well as two newer lintels on the west façade (Figure 3). The original doorways between the Header Houses and the greenhouses are now filled with exposed concrete block. The hardware on both the interior and exterior of the building is brass which has been painted in some cases and left exposed in others. Asphalt roof shingles, painted wood trim with lead flashing complete the building envelope.



Figure 5. A brass hinge on a wooden door, both of which have been painted.

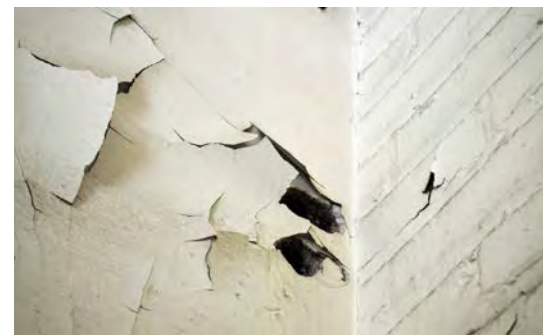

Figure 6. L to R: a plaster wall and a brick wall, both painted.



Figure 7. A wooden beam and wood paneling, both painted.



Figure 8. A cast iron radiator.

The interior walls of the building are clad in a combination of brick and plaster as shown in Figure 6. All outside walls have an interior surface of brick that has been heavily painted. Interior walls are finished in plaster which ranges in condition from very poor to good. The floor of the building is painted concrete in some areas and or vinyl composition tiles in others. As Figure 7 illustrates, the ceiling is clad in painted wood paneling between exposed painted wooden beams. Interior doors are also made from wood which has been painted (Figures 5 and 9). A 1920 photograph shows that the wooden elements were painted by that time. Most of the windows have steel security bars (Figure 9), which are a recent addition. Heat is supplied via cast iron radiators, which are original.



Figure 9. Steel bars have been retrofitted over the interior side of the windows.

The basement of the Header Houses is largely unfinished. The floor is exposed concrete as is the ceiling, which forms the floor above. Partitions and doors were built with wood, most of which have been painted.

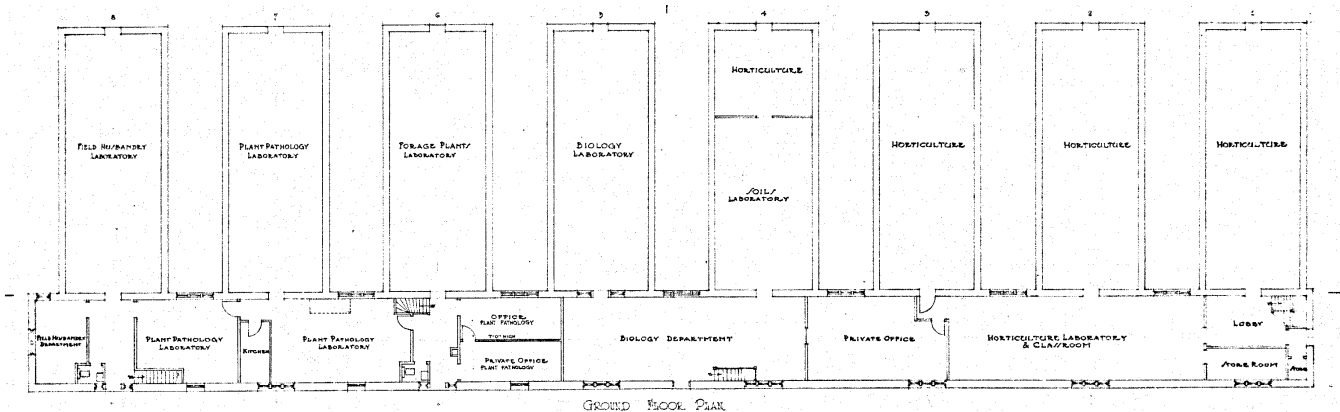

Figure 10. Plan of the Horticulture Building with its green houses attached. The 'Header Houses' along the bottom of the plan are all that remain. The plan is oriented with north facing down. Retrieved from Facilities Management Division Asset Record System, File HG-15-T.

2.2 Form

The Header Houses are low and linear in form, measuring only 18 feet, 8 inches wide but approximately 234 feet long, and consisting of one floor above ground level, and a basement. The roof is pitched across the building's narrow dimension, with a series of 7 intersecting dormers. The interior ceiling height is 11 feet. The main entrance on the north side was added in 1973.

The form of the Horticulture Building relates to its original function, as a support space for a series of greenhouses. The original floor plan is shown in Figure 10. At one time, eight large green houses, each about 50 feet long, were connected to the south side of the building. These greenhouses were added over time and to accommodate them, the Header Houses were expanded as well. The gable ends of the multiple dormers on the north side give the building the appearance of being composed of several adjacent buildings, which contributes to their perception as 'Header Houses.'

2.3 Style

The style of the Horticulture Building is Arts & Crafts, a mainly domestic style of architecture of the latter half of the 19th century affiliated with the Victorian Gothic revival. The Arts & Crafts movement favoured traditional craftsmanship, simple forms, and manual production techniques. The style shares many characteristics with the Collegiate Gothic used elsewhere at the university; however, the detailing of the Horticulture Building is simplified, in accordance with its original function as an agricultural service building. The dormers on the north elevation

are a characteristic of the Arts & Crafts style. Several of the windows and doors are set into arched openings (Figure 12). Greystone quoins frame the building's corners and constitute another character-defining element. The eaves are ornamented with shaped wooden rafter extensions (Figure 13). Two cupolas protrude from the roof, providing attic ventilation as well as decoration (Figure 14).



Figure 14. One of two cupolas on the roof of the Horticulture Building.



Figure 11. The gable ends of the dormers give the Header Houses the appearance of a row of buildings.



Figure 12. An arched doorway with arched transom and side lites.



Figure 13. Exposed wooden rafter ends.



Figure 15. The shadows in this photo show the orientation of the Header Houses in relation to the sun. Photo A-425 retrieved from <http://scaa.sk.ca/gallery/uofsbldings/>

2.4 Location & Spatial Configuration

The Horticulture Building was not specifically noted in the 1909 Campus Plan. Its orientation is more significant than its location. The greenhouses were oriented to the south to maximize their solar exposure, therefore the Header Houses were attached to their north side. The stone walls of the Header Houses also functioned as a passive thermal storage device, and were positioned to receive heat from the sun during the day. Heat would be released into the greenhouses at night, regulating their temperature. The configuration of the Header Houses as a long heavy mass with a broad façade facing the south is thus a character-defining element.

Due to its unique form, the interior of the space has a distinct configuration. The ground floor is narrow, yet spacious in feeling owing to its relatively high ceiling. The linear floor plate of the Horticulture Building is one of its most palpable character-defining elements. Several doors and windows are located along the north side of the building, providing ample natural light due to the narrow floor plate.

The south side of the building no longer features any openings. With the demolition of the green houses and subsequent construction of the Kinesiology Building, all of the south-facing openings were filled in with concrete block (Figure 16).



Figure 16. Concrete block fills the openings on the south side.

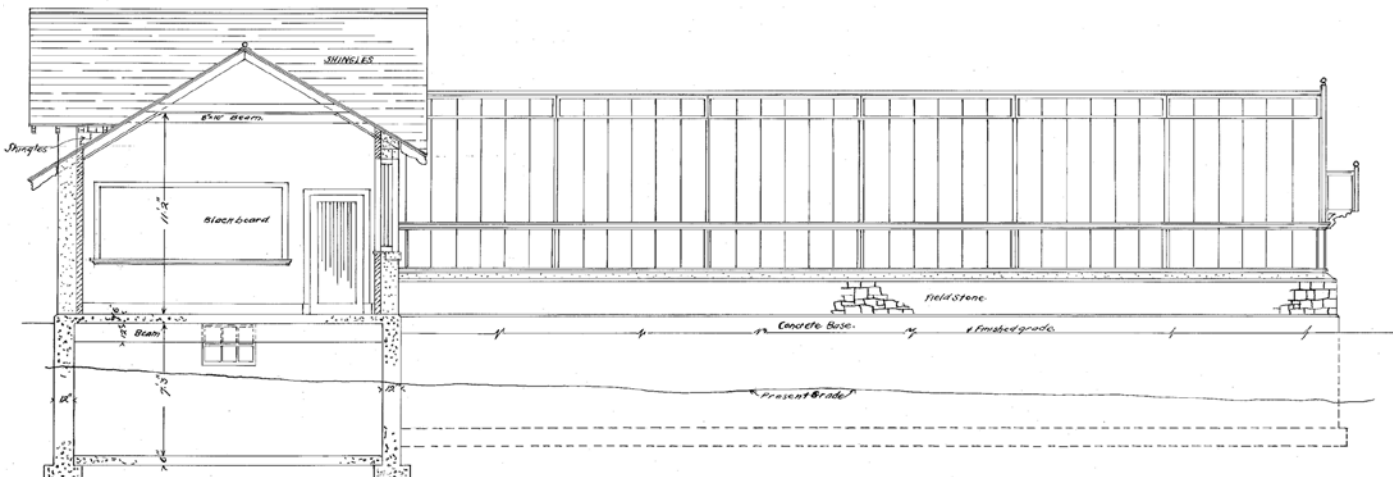

Figure 17. Cross section. Retrieved from Facilities Management Division Asset Record System, File HG-19-T.

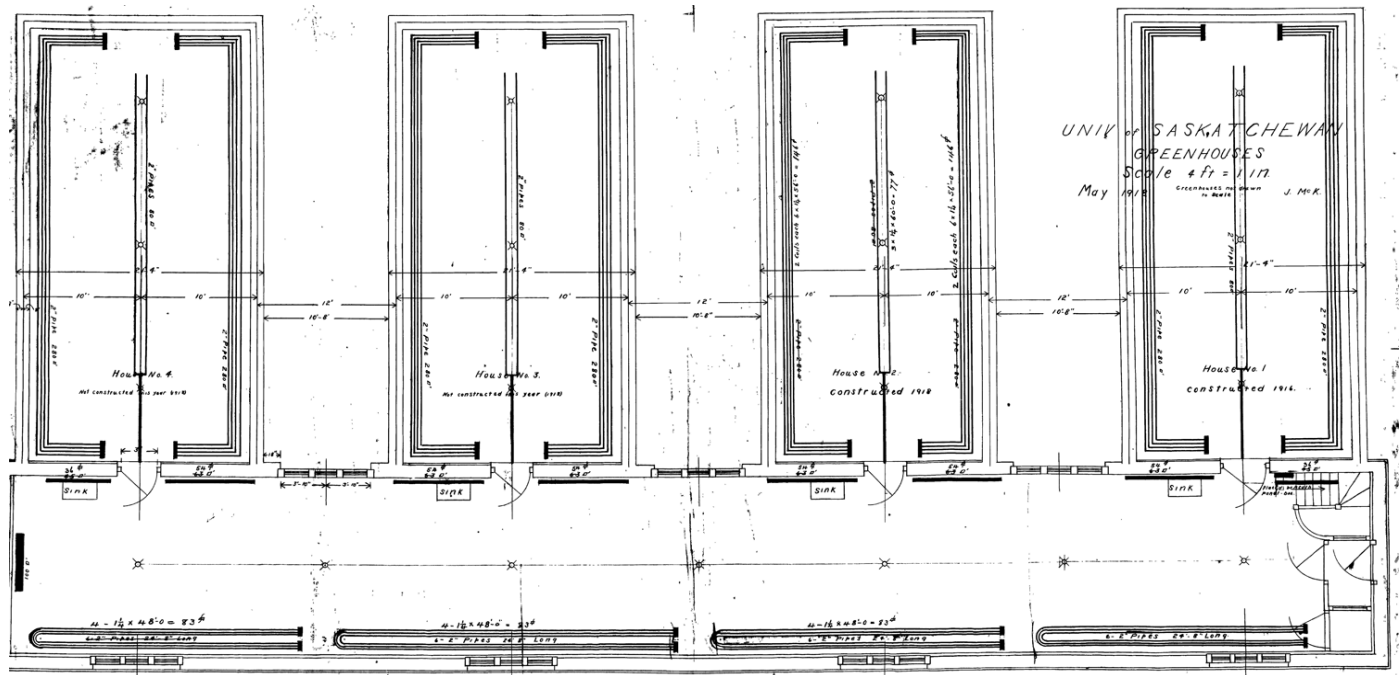

Figure 18. Floor plan showing heating pipes in the greenhouses and header houses. Retrieved from Facilities Management Division Asset Record System, File HG-1-T.

2.5 Systems

The narrow floor plate of the Horticulture Building allows its roof to be supported by a series of simple trussed rafters, which are concealed on the inside of the building by wood paneling, but are visible on the exterior as exposed rafter ends. Wooden beams supporting the rafters of the large dormers are visible on the interior. The foundations and basement walls are cast-in-place concrete. Concrete beams support the ground floor concrete floor. No interior columns are required. The exterior walls are of load-bearing stone and brick masonry. Figure 17 provides a cross section of the building.

The Horticulture Building was provisioned with radiant heating pipes which ran around the perimeter of each greenhouse. The greenhouses and their piping systems were demolished; however, the same provision was made, on a smaller scale, in the Header Houses. Some of these pipes still exist and can be found along the base of the exterior walls. Figures 18 & 19 show this system of pipes.



Figure 19. Radiant heating pipes still visible in the Horticulture Building.



Figure 21. 1920, the first medical teaching facility on campus: a bacteriaology lab set up by W.S. Lindsay in one of the Header Houses. Photo A-427 retrieved from http://scaa.sk.ca/gallery/uofs_buildings/



Figure 22. A histology class taking place inside the greenhouses, 1935-1936. Retrieved from Buchan, D.J., (1983) *Greenhouse to Medical Centre Saskatchewan's Medical School 1926-78*.



Figure 23. Medical School, class of 1931 outside the Header Houses. Photo A-5742 retrieved from http://scaa.sk.ca/gallery/uofs_buildings/



Figure 20. The greenhouses. Photo A- 3095 retrieved from http://scaa.sk.ca/gallery/uofs_buildings/

2.6 Use(s)

Horticultural education and research were the impetus behind the construction of the Horticulture Building. Horticulture is the industry and science of plant cultivation including the process of preparing soil for the planting of seeds, tubers, or cuttings. The Header Houses served to support the functions of the greenhouses. Classrooms, offices, laboratories, and preparation rooms to support plant pathology, horticulture, field husbandry, forage plants and soils were all housed in the Header Houses. All of these uses were located on the ground floor. The basement held storage and work rooms.

From 1926 until 1937 the Header Houses served as the School of Medical Sciences. In 1937 the medical students moved into the [Archaeology Building](#), known at the time as the Crop Science Building. Figures 21 - 23 document the use of the Header Houses for medical education.

Currently the ground floor of the Header Houses is used for storage, and the basement is unused.

2.7 Cultural & Chronological Associations

The Horticulture Building is associated with agriculture and agricultural education at the University of Saskatchewan. Although the greenhouse portion of the building has been removed, its distinct form is a reminder of its original purpose.

The Header Houses are also associated with the College of Medicine at the University of Saskatchewan. (See Section 2.6 Uses).

3. Associated Objects

N/A

4. Supporting Documents

Buchan, D.J. (1983). *Greenhouse to Medical Centre: Saskatchewan's Medical School 1926-78*. Saskatoon: University of Saskatchewan.

Facilities Management Division (2011). Asset Resource Database [Data File]. Retrieved from \\usask\fmddfs\files\iis\IIS_Public\ARS.

University of Saskatchewan Archives. (Retrieved 2012). *Campus Buildings: Horticulture Greenhouse*. Retrieved from http://scaa.sk.ca/gallery/uofs_buildings/.



5. Summary of Character - Defining Elements

Materials

- greystone walls
- Indiana limestone trim
- Tyndall stone thresholds
- oak window frames, doors and surrounds (painted)
- wood paneling (painted)
- lead flashing
- brick
- concrete
- plaster
- brass fixtures
- cast iron radiators
- single-glazed windows
- cast iron radiators

Form

- long and narrow form

Style

- arched doorways and windows
- keystones
- cupolas
- quoins
- exposed rafter ends

Location & Spatial Configuration

- solar orientation
- high ceiling on ground floor
- narrow, long floor plate
- several entrances and exits

Systems

- rafters supported by exterior walls
- heating pipes & radiators

Uses

- horticultural education and research
- medical education

Cultural & Chronological Associations

- agriculture
- College of Medicine



006

Saskatchewan Hall



006

Saskatchewan Hall

Alternate Names

University Hall
Students' Residence
Sask Hall

Architect(s)

David R. Brown and Hugh Vallance, Brown and Vallance Architects, Montreal

Builders

Smith Brothers and Wilson, General Contractors

Construction Dates

1910-1912

Recognition

University of Saskatchewan 'A' Listed

1. Statement of Significance

Saskatchewan Hall is architecturally and historically significant for its age, Collegiate Gothic architectural style and its status as the first student residence at the University of Saskatchewan. One of the first three buildings approved by the Board of Governors in 1909, a student residence was seen as crucial to the young university. Residence halls were chosen explicitly over fraternities, as they were considered by Walter Murray, the University President, to be more democratic. Saskatchewan Hall housed both women and men from the outset; a separate wing with a capacity of 30 students was reserved for women. Saskatchewan Hall was completed for \$230,000 – over double the original estimate of ‘not more than \$100,000.’ However, the result was a landmark building of impressive quality, resolved to a high degree of detail. Saskatchewan Hall retains a great degree of heritage value, particularly in its exterior elements.



Figure 1. Cut sandstone and rough-faced 'greystone' over a granite base course.



Figure 2. Copper drainage gutter and exposed wooden rafter ends.



Figure 3. A rendering of Saskatchewan Hall, produced by architects Brown and Vallance. Photo B-389-C, retrieved from University of Saskatchewan Archives.

Note: Saskatchewan Hall is configured with floors numbered Basement, Ground Floor, First Floor, Attic. This report follows the same convention.

2. Character - Defining Elements

2.1 Materials

The characteristic combination of ‘greystone’ and sandstone forms the exterior of Saskatchewan Hall. The principle material is rough-faced greystone, while cut sandstone is used for quoins, grotesques, crenellation, door and window surrounds. At the entrances, granite forms a base course and stairs. Figure 1 illustrates these materials. (For further information on building stones used at the U of S, refer to [‘Appendix: Stone.’](#))

The roof of Saskatchewan Hall is clad in slate, with copper eaves troughs. At the eaves, exposed wooden rafter ends provide decoration. Figure 2 illustrates the eaves detailing, and Figure 4 illustrates the slate roof tiles. The exterior doors are oak with glass lites. These are not original, but were made using the doors of [Qu’Appelle Hall](#) as a reference.

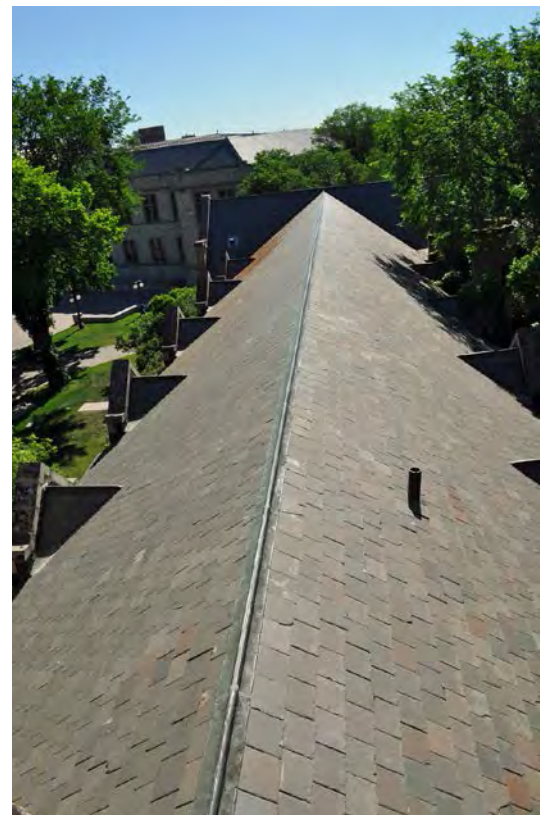

Figure 4. Slate roof tiles.



Figure 5. Quarter sawn oak on a fireplace mantle.



Figure 6. An oak door with brass hardware.



Figure 7. Oak, brick and red clay terracotta floor tile frame a fireplace.

Slate is continued on the interior of the building, with slate floor tile in the entrances and stairwells. All of the slate is original save for tiles that were added to the entrances and in the basement. The slate material is of excellent commemorative integrity. No other original flooring materials remain; the ground floor now has sheet vinyl, the upper floors carpet. A 1971 renovation removed all of the original wooden flooring. Carpet was installed over a new concrete floor slab. The basement features a mixture of concrete flooring and the recent addition of ceramic and slate tiles.

Finished in a painted textured plaster, the interior walls of Saskatchewan Hall maintain little commemorative integrity, having been refinished numerous times. The original plaster ceilings have been obscured by dropped ceiling panels added to conceal newer building services.

Interior millwork features, such as fireplace mantles, door and window trim are constructed of stained quarter sawn oak as shown in Figure 5. Wooden picture moldings inside the residence rooms have been painted. The stained oak door surrounds of the residential rooms have been well maintained; however, over time as certain pieces experience wear and damage, replacements have been made. In the corridors, some original oak doors have been replaced with steel doors and frames, as a fire protective measure. A few original oak doors remain to ancillary spaces such as the stairwell to the roof or attic crawl spaces. Figure 6 illustrates an example.

In the second floor lounge, two brick fire places with oak surrounds and red terracotta tile hearths stand facing each other (Figure 7). Between them is an oak window seat, shown in Figure 8, set into the niche of an oriel window. The main floor features a much larger and more central fireplace. At least two other fireplaces in the south end of the building have been hidden under more recent wall finishes. Their general locations are apparent from the chimneys extending through the roof.

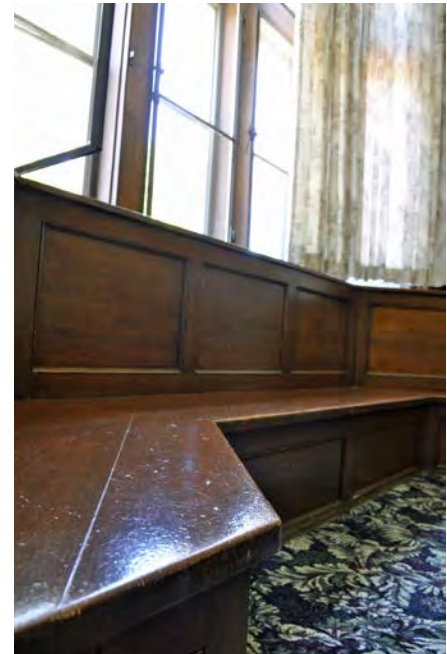

Figure 8. An oak window seat.

Also original are the oak surrounds of many of the windows. Set into these oak surrounds are single-paned steel framed sash windows. Much of the original glass is still intact, as is the original brass hardware. In most instances, aluminum storm windows have been fitted over the original windows, as shown in Figure 9. In a few cases, the original steel-framed exterior insect screens are intact. (See Figure 10). Overall, the windows of this building have excellent commemorative integrity.

The staircases also retain excellent commemorative integrity. They are made in the same form and style as the staircases that typify other early University of Saskatchewan buildings such as the [MacKinnon Building](#) and the [Physics Building](#). Slate treads and landings are complemented by a steel and iron balustrade and stringers finished in black paint.



Figure 9. Aluminum framed storm windows with sliding screens have been added to the exterior.

The steel and iron balustrade features subtle decorative details and oak hand rails. Staircases designed in this style are a unifying feature of University of Saskatchewan interiors; most staircases in early university buildings are designed in the style described here.

The washrooms on all floors feature marble stall dividers. The marble is approximately one inch thick and is also used for baseboards and backsplashes in the washrooms.



Figure 10. A window with both screen and exterior glass intact.

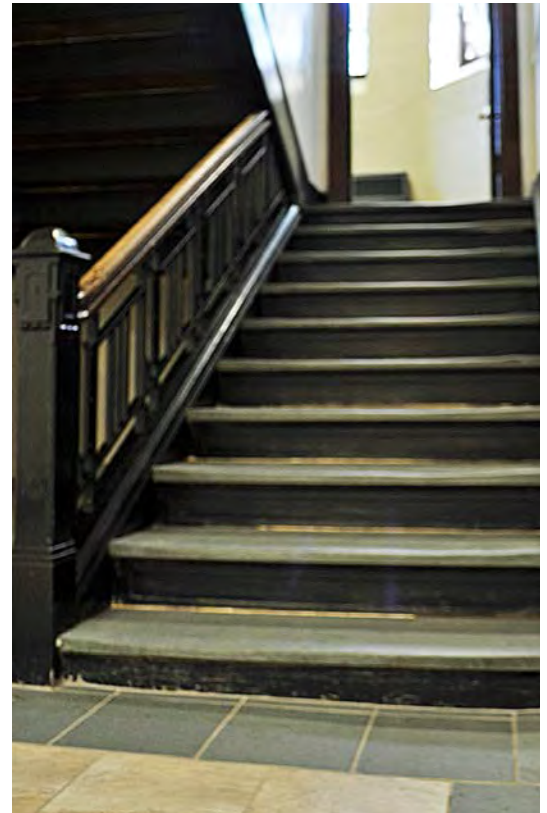

Figure 11. A staircase featuring slate treads, steel and iron balustrade and oak handrail.



Figure 12. Marble as a backsplash in a Saskatchewan Hall washroom.



Figure 13. Saskatchewan Hall in its original form as viewed from the north, ca.1916. Photo A-792, retrieved from <http://sain.scaa.sk.ca/items/index.php/saskatchewan-hall-4;rad>.



Figure 14. The form of Saskatchewan Hall in plan is indicated in green. Its shape provides for the framing of outdoor spaces. North is to the left.



Figure 15. The form of Saskatchewan Hall with Athabasca Hall added to it is indicated in green on this contemporary campus map.

2.2 Form

The form of Saskatchewan Hall is important to the early Campus Plan set out by Brown and Vallance Architects. In plan, the building is shaped as a capital letter F, as illustrated in Figure 14. This shape forms exterior courtyards which were a primary goal of the 1909 campus plan. This master plan was as much a landscape plan as it was an architectural vision, and it conceived the university grounds as a series of interconnected courtyards formed by their adjacent buildings. The courtyards vary in scale from the grandeur of 'The Bowl' to the intimacy of the smaller courtyards behind Saskatchewan Hall. The form of Saskatchewan Hall was intended by the 1909 plan to define the shape, scale and character of The Bowl and the other outdoor courtyards such as Voyageur Place. The scale of Saskatchewan Hall is consistent with the other buildings that enclose The Bowl. At a height of three stories above ground, Saskatchewan Hall is well proportioned to the pedestrian activity that takes place around it. The landscaped courtyards around the university's early buildings still retain their character and are in and of themselves important character-defining elements.

No deletions have been made to the form of Saskatchewan Hall, but Athabasca Hall was added to it in 1964. Figure 15 illustrates how this has extended the building footprint south and east. Despite the addition, the original form of the building is still easily discerned.



Figure 16. An elevational view of Saskatchewan Hall from the west. Photo A-27, retrieved from <http://sain.scaa.sk.ca/items/index.php/?search?page=2&query=a-27&limit=10>.



Figure 17. Dormer windows.

2.3 Style

Numerous character-defining elements of the Collegiate Gothic are to be found on the building's exterior. The north and west-facing facades are the most ornamented, owing to their frontage onto The Bowl and Voyageur Place (Figures 13 & 16). The roof of Saskatchewan Hall is clad in slate tile; a material common to many Collegiate Gothic buildings at the university. Punctuating the roof is a series of dormer windows shown in Figure 17. Below the crenellated parapets that make up the roof line, a number of gothic grotesques populate the exterior. Both of these character-defining elements are visible in Figure 18. The grotesques are particular to this building, and portray aspects of student life. The figures are carved holding tennis rackets, microscopes and musical instruments. Shown in Figure 19, around the northwest entrance to the building, the arched stone entry is embellished with reliefs featuring flora and fauna such as a gophers and grape vines. A shield depicts a stylized key. The carved grotesques and reliefs all exist in excellent commemorative condition. Their contribution to the style of the building and the subject matter they portray make them important character-defining elements.



Figure 18. Crenellated parapets define the roofline. Two grotesques are shown, one using a microscope and the other playing a drum.



Figure 19. The arch framing the main entry is embellished with stone reliefs and heraldry.



Figure 22. An arched entry.



Figure 23. String courses and quoining.

Above the northwest entrance, an oriel window overlooks Voyager Place. (Figure 20). The oriel window is accompanied by a series of bay windows on both the north and west elevations. (Figure 21). Sandstone quoins, ornamented drainage spouts and narrow archer slits contribute to the Collegiate Gothic architectural style of the building. Carved stone arches surround the two west entrances (Figure 22). String courses, as illustrated in Figure 23, are used to accommodate the thickening of the exterior stone towards the base of the building, while adding a decorative element. Many windows also feature sandstone arches. On the north façade, a turret reaches from the ground floor to the roof, further defining the neo-gothic style of the building (Figure 24).

Notably, many of the windows on the building's east facing walls are less ornamented than those on other elevations. Only a few windows on these facades have bays, balconies or oriels. This differentiation orientates the building toward the more public outdoor spaces of [The Bowl](#) and [Voyageur Place](#). As Figure 25 shows, the windows appear in sets of nine with large surface areas to maximize light penetration. With renovations, some of these windows have been replaced. The dining room used to feature a double-height vaulted ceiling. Renovations converted this grand space into two floors. To conceal the addition of the floor the three middle windows were covered in each set.



Figure 20. Oriel window.



Figure 21. A bay window with a false balcony.



Figure 24. A turret on the north side of Saskatchewan Hall.

The interior of Saskatchewan Hall has varying levels of commemorative integrity with respect to architectural style. The ground floor has been much more compromised than the upper stories. On the upper floors, some of the original plaster work, and most original fireplaces, stairwells and window seats have been maintained to an excellent standard of commemorative integrity. However, in general, the preservation of historical character-defining elements in this building has been inconsistent. Figure 27 illustrates an example of this inconsistency.



Figure 25. Understated windows on the east side of Saskatchewan Hall.

2.4 Location

Saskatchewan Hall is located according to the 1909 Campus Plan, illustrated in Figure 28, on the south side of The Bowl. The importance of the residence hall to the university's planners is evident from its prominence, at the heart of the campus.



Figure 28. Saskatchewan Hall is indicated in green on the 1909 Campus Plan. North is to the left.

Its location has also been integral to the formation of the Collegiate Gothic precinct of early university buildings ringing The Bowl. Saskatchewan Hall helps to define a north-south axis through the centre of The Bowl, terminated on the north side by the [Physics Building](#) and on the south by Voyageur Place.



Figure 26. A detail found on all staircases in Saskatchewan Hall.

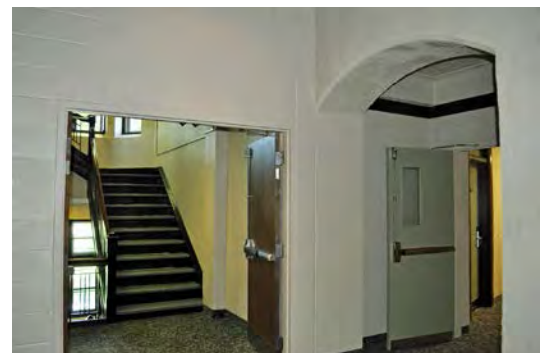

Figure 27. L to R: A newer doorway, without arch, compared with an original arched doorway.

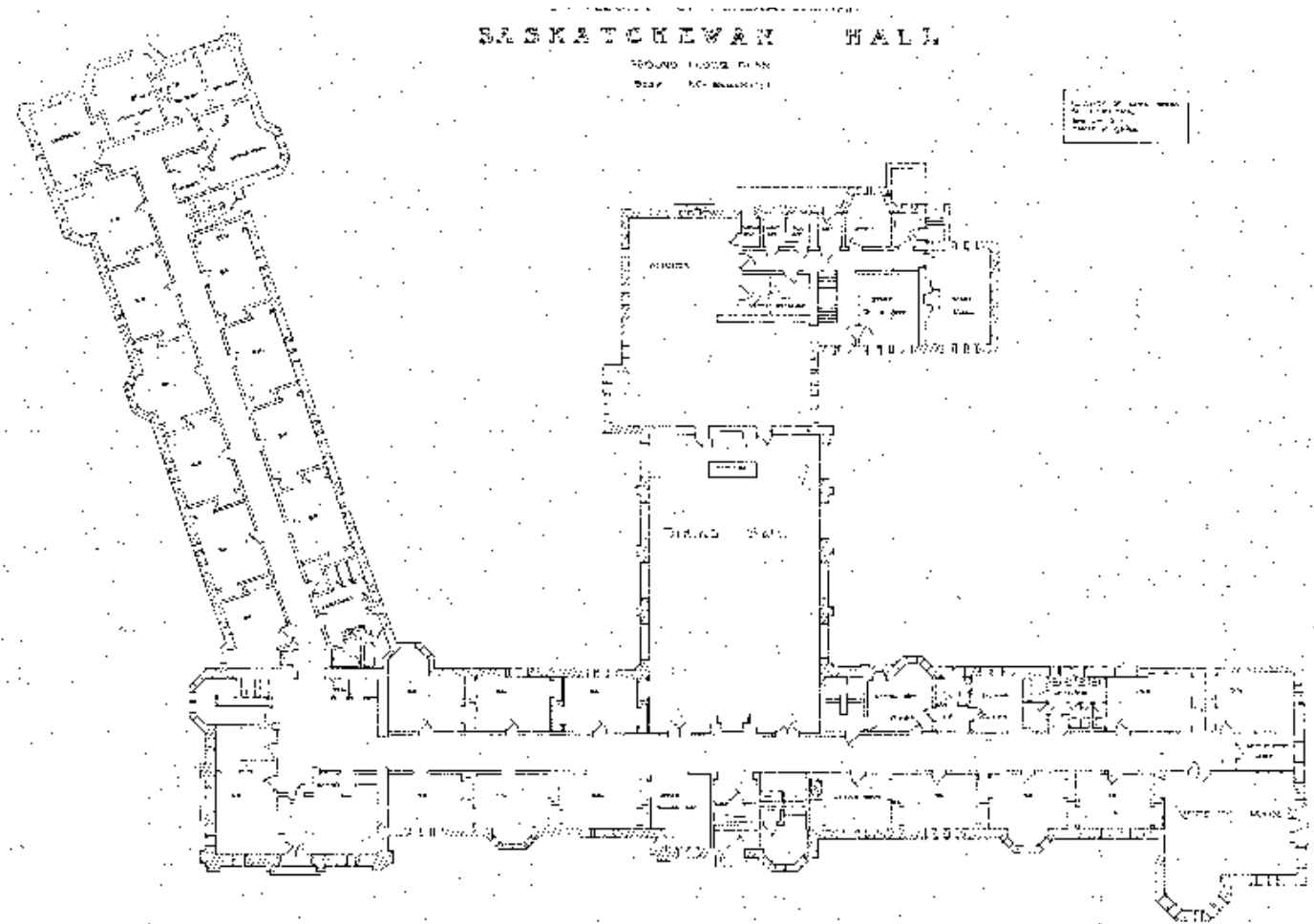

Figure 29. The ground floor plan of Saskatchewan Hall ca. 1947. Uses have changed, however the double loaded corridor layout has been maintained. The dining room and kitchen spaces have been converted into office space. Retrieved from Facilities Management Division Asset Record System, File SH-8-T.



Figure 30. Bay windows act as lightwells for the building. Arches are a common stylistic characteristic.

2.5 Spatial Configuration

The general arrangement of Saskatchewan Hall is a series of narrow wings, with spaces arrayed off a double-loaded corridor. The floor plan is illustrated in Figure 29. This arrangement is typical of multi-unit residential construction, where all living spaces require access to windows. Narrow floor plates allow the greatest possible penetration of natural light into interior spaces. Even stairwells featured large bays of windows to allow for maximum light penetration. Figure 30 illustrates this feature.

The arrangement of rooms in Saskatchewan Hall has undergone greater transition in some areas than in others. The building was designed with student dormitory rooms arranged around a series of double loaded corridors, and with a central wing housing a dining hall. The double loaded corridor layout has



Figure 31. Saskatchewan Hall dining room, ca. 1920. Photo A-2148 retrieved from http://scaa.usask.ca/gallery/uofs_students/image_detail.php?image=a-2148

been maintained and is illustrated in Figure 29. The dining hall was the exception to this general cellular arrangement, but has since been compromised both in plan and section. The dining hall was located in the central wing running east-west. Originally two stories in height, the dining hall wing featured a high coffered ceiling. A series of windows on either side created an expansive, light-filled space. A large fireplace was located centrally on the west wall of this grand room. Figure 31 shows the original use of the space and its open configuration. Renovations in the 1950's saw the height of the room completely altered with the addition of another floor over the dining space to provide a gymnasium. This fundamentally altered the nature of the space, dividing it vertically into two lower spaces. Figure 32 shows the gymnasium that was added over the dining hall.



Figure 32. The gymnasium in Saskatchewan Hall. The roof and windows pictured here used to overlook the dining hall.



Figure 33. The current layout of the space originally used as a dining room. Few stylistic elements remain.



Figure 34. The dining room hearth, now located in an administrative office.

The space of the former Dining Hall has also been made more linear, by its division into a number of administrative offices arranged along a single loaded corridor. Athabasca Hall, added in 1964, is accessed through this corridor, reinforcing the conversion of the space from a gathering place to a circulation route. Figure 33 shows this reconfiguration of the former Dining Hall. For decades, the grand hearth of the Dining Hall was lost behind furred out walls. In 2010, the fireplace was rediscovered during a renovation. Although no longer functional, its material characteristics and architectural style are well maintained and in an excellent state of commemorative integrity. Figure 34 shows the hearth. Other chimneys protruding from the roof perhaps give a clue to several other hidden hearths within the building.

Student lounges in Saskatchewan Hall were provided with higher ceilings and tall windows to allow more light into these public spaces. The spacious dimensions of the student lounge and the tall windows that give it ample natural light are character-defining elements of that space. The lounge is also home to a hearth and a window seat; elements that invite gathering and define the room as a public space.

Over the years, several tunnels have been connected to the basement of Saskatchewan Hall. A first set of tunnels offered access to Marquis Hall, Place Riel and the [Memorial Union Building](#). Another tunnel connected the eastern end of the northeast wing to the [MacKinnon Building](#).



Figure 35. Saskatchewan Hall under construction, November 1, 1911. Photo A-786, retrieved from University of Saskatchewan Archives.

2.6 Systems

The original structure of Saskatchewan Hall consists of cast-in place concrete slabs supported by concrete beams and columns. The roof rafters are wooden, and are supported by the concrete frame. The exterior walls of Saskatchewan Hall are of stone, supported on concrete foundation walls and footings. At the exterior stone walls, the concrete structure is buried within the masonry construction and is not visible, but is evident in photographs taken during construction. On the interior, a pair of concrete beams runs on either side of the central corridors, parallel to the exterior walls. This early concrete structure proved problematic, and in 1971, an extensive rehabilitation project was undertaken to reinforce it. Excessive deflection in the concrete beams was addressed by the addition of steel supporting columns at the midspan of each structural bay. An additional structural concrete slab was poured over top of the existing one both to strengthen it and to level the floors, which had sagged due to structural deflection. The exterior stone walls, although not intended as load-bearing, have likely assumed a supporting function, given the deflection visible in the interior concrete beams.

A notable structural feature is the relieving arch visible in Figure 36, supporting a stone chimney over a window overlooking the Bowl.



Figure 36. A stone relieving arch helps to support the wall over a window.



Figure 37. Two female residents relax in in Saskatchewan Hall. Photo A-833, retrieved from http://scaa.usask.ca/gallery/uofs_students/image_detail.php?image=a-2148



Figure 38. The 'Convocation Moose', newly installed in its new home in the Saskatchewan Hall lounge.

2.7 Use(s)

Saskatchewan Hall is historically significant as the first student residence at the University of Saskatchewan. The construction of a residence hall was considered by the early Board of Governors and by President Walter Murray to be a priority for the university. It was one of the first three buildings approved in 1909, and put out to tender in 1910. It was assigned a prominent location on the Bowl, at the heart of the new campus. The decision to build a residence rather than start a fraternity system was a conscious one; Murray and the Board believed residences were the more democratic choice. Saskatchewan Hall has been used as a residence hall continuously throughout its history. Other secondary uses have varied according to need; the dining room was decommissioned after the construction of Marquis Hall in 1964. The basement has seen many uses; it is currently home to various campus clubs and a prayer and meditation room. For many years it housed student health services.

2.8 Cultural & Chronological Associations

As the first residence at the University of Saskatchewan, this building is strongly associated with campus life for generations of students. These associations are reinforced by its central location, its human scale and the decorative carvings which celebrate its history and purpose.

3. Associated Objects

The moose head that currently adorns the student lounge in Saskatchewan Hall is an object associated with the whole university. The stuffed moose head, shown in Figure 38, was donated to the university in 1921 by Dr. T.A. Patrick of Yorkton. The President at the time, Dr. Walter Murray, decided that the moose "should be placed in Convocation Hall, directly above the front entrance." The moose hung here from 1921 until 2005 when the [MacKinnon Building](#) was renovated, and came to be known as the 'Convocation Moose'. The renovations required that the moose find a new home as there was no longer room for it at its historical location. Several facilities at the university offered to become home for the celebrated moose. President Peter Mackinnon chose Saskatchewan Hall due the abundance of people that would be around to ensure its safety. The moose was installed in its current location in January 2006.

4. Supporting Documents

Author Unknown. (February 3, 2006). A (Moose) Moving Experience. *On Campus News*, 13(11). Retrieved from http://news.usask.ca/archived_ocn/06-feb-03/news02.shtml

Author Unknown. (September 9, 2005). Convo Hall Moose Head Looking for New Home. *On Campus News*, 13(2). Retrieved from http://news.usask.ca/archived_ocn/05-sep-09/news/shtml

Author Unknown. (September 23, 2005). Convo Moose still on the Loose. *On Campus News*, 13(3). Retrieved from http://news.usask.ca/archived_ocn/05-sep-23/news03.shtml

Author Unknown. (October 7, 2005). Moose Moves into Residence. *On Campus News*, 13(4). Retrieved from http://news.usask.ca/archived_ocn/05-oct-07/news02.shtml

Facilities Management Division (2011). Asset Resource Database [Data File]. Retrieved from <\\usask\fmddfs\files\iis\IIS Public\ARS>

G. Snell, personal communication, July 7, 2011.

Hayden, M. (1983). *Seeking a Balance: The University of Saskatchewan 1907-1982*. Vancouver: University of British Columbia Press.

Kirkham, Willis. (2012). *The Northeast Swale and Early University of Saskatchewan Buildings*. Report to the Meewasin Valley Authority.

Morton, Arthur. (1959). *Saskatchewan: The Making of a University*. Toronto: University of Toronto Press.

Murray, D.R. & Murray, R.A. (1984). *The Prairie Builder: Walter Murray of Saskatchewan*. Edmonton: NeWest Press.

Taft, M. (1984). *Inside These Greystone Walls*. Saskatoon: University of Saskatchewan.

University of Saskatchewan Archives. (Retrieved 2011). *Campus Buildings: Saskatchewan Hall*. Retrieved from http://scaa.sk.ca/gallery/uofs_buildings/



5. Summary of Character - Defining Elements

Materials

- greystone walls
- cut sandstone trim and detailing
- granite base
- quarter sawn oak mantles, seating, banisters, picture moldings, doors, window frames and surrounds
- red terracotta tiles
- steel-framed windows
- brass hardware
- steel and iron balustrades
- slate treads, landings and roof tiles
- marble dividers and backsplashes
- exposed wooden rafter ends
- brick hearths

Form

- formation of exterior courtyards
- scale (3 storeys)

Style

- slate tile roof
- dormer windows
- crenellated parapet
- grotesques and stone relief sculptures
- arches (stone entries, fireplaces, windows, interior entries)
- oriel window and bay windows
- quoins in stonework at corners
- archer slits
- ornamented drainage spouts
- string courses
- turret
- coffered ceiling



Location

- original to 1909 campus plan
- north south axis

Spatial Configuration

- double loaded corridors
- hearths
- window seat
- deep window sills
- high ceilings
- tall windows

Systems

- relieving arch
- concrete structural frame
- exterior stone walls

Uses

- student residence
- dining hall
- campus clubs

Cultural &
Chronological
Associations

- Carved stone grotesques depicting student life



007

Administration Building



007

Administration Building

Alternate Names

New Administration Building, Administration Building Addition

Architect(s)

Clifford Wiens, Wiens Johnstone Architects, Regina

Builders

Penn-Co Construction

Construction Dates

1985-1987

Recognition

N/A

1. Statement of Significance

The Administration Building was built in response to the slow decline of the [MacKinnon Building](#), parts of which were declared unsafe due to structural failure in 1979. The choice was made to build new building adjacent to the old structure and construction began in 1985, with the building opening in 1987. The Administration Building was designed by Clifford Wiens, one of Saskatchewan's most notable architects of the 20th Century. Clifford Wiens began his practice in Regina in 1956. He has earned Canada's highest award for architecture, the Massey Medal, three times. The Administration Building exhibits Wiens' trademark use of simple tectonic forms and original construction details. The building cost \$6.6 million and comprised 4,646 square meters, giving it office space equal to that of the MacKinnon Building. Many interior spaces in the Administration Building are defined by the enclosure of the exterior walls of the MacKinnon Building. A small courtyard to the north of the building was enclosed as an addition to the Administration Building in 1997. The addition is beyond the scope of this report.

Note: The Administration Building is configured with floors numbered, Ground Floor, First Floor and Second Floor. This report follows the same convention.



Figure 1. Tyndall stone and greystone above a precast concrete base.



Figure 2. Painted concrete wall.

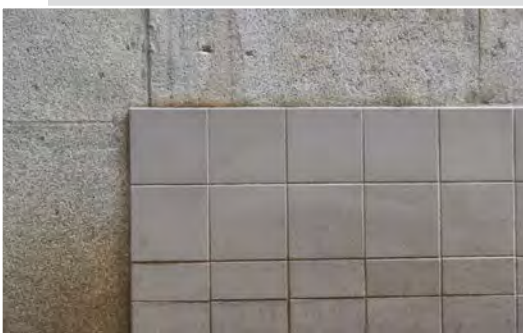

Figure 3. Grey ceramic tile.



Figure 4. A 1985 architect's rendering of the Administration Building. The entrance canopy was later removed. An addition in the form of a glazed atrium now takes its place. Photo A-3463, retrieved from University of Saskatchewan Archives.

2. Character - Defining Elements

2.1 Materials

The exterior materials of the Administration Building are in keeping with those of the [MacKinnon Building](#) to which it is an addition. 'Greystone,' which has come to characterize the University of Saskatchewan campus, is the primary exterior material. Greystone is complemented by cut Tyndall stone. Precast concrete panels form a base for the exterior walls. (For further information on building stones used at the U of S, refer to ['Appendix: Stone.'](#)) All three of these materials are illustrated in Figure 1 and are in excellent commemorative condition. Glazing is modern in its materiality, featuring double-glazing and aluminum frames.

Painted exposed concrete is a primary element on the interior of the building and a character-defining material (Figure 2). Concrete columns are also left exposed throughout the building. The main stair features a balustrade made of concrete. The concrete is often accompanied by grey tile which appears on window sills, around the bases of columns and as a cap on the concrete balustrade (Figure 3). Doors in the building are either oak (Figure 5) or painted steel. Door hardware has a brass finish, also shown in Figure 5. Painted steel is used for handrails and balustrades (Figure 6).



Figure 5. Brass-finish door handle.

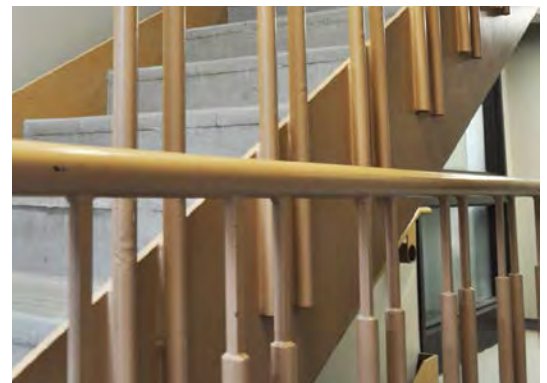

Figure 6. Painted steel balustrade.



Figure 7. Triangular entrance canopy, now demolished. Photo A-7071, retrieved from http://scaa.usask.ca/gallery/uofs_events/articles/1956.php



Figure 8. Abstracted references to Collegiate Gothic forms.



Figure 9. Reference to keystones in the stonework above the windows.

2.2 Form & Style

The Administration Building is Post-Modern in style, featuring references in form, detail and materiality to the historical architecture of the campus, but simplified in its detail. As illustrated in the architect's rendering shown in Figure 4, the Administration Building takes its scale and formal cues from the adjacent [MacKinnon Building](#). The building is roughly T-shaped in plan, connecting to the back of the MacKinnon Building with a recessed entrance and lobby. Originally the entrance was marked by a triangular canopy (Figure 7), which was removed during a later expansion. The front face of the building features a shallow bay with a gabled roof line, referencing similar details on the MacKinnon Building and other collegiate gothic examples (Figure 8). The height of the Administration Building, at three storeys above grade, roughly matches that of the MacKinnon Building.

The exterior stone detailing references historical precedents in materiality and form, but is abstracted through the use of simplified ornamentation. For example, cut Tyndall stone is used as a trim around window openings, but the lintel is given an exaggerated depth and a reference to a keystone above the windows is highly abstracted (Figure 9). Cut Tyndall stone is also used at the parapet and scuppers along the roofline. These exterior stone details are character-defining.

2.3 Location

The Administration Building was constructed as an addition to the MacKinnon Building which was at the time slowly losing its function due to structural degradation. Its location adjacent to the MacKinnon Building, (Figure 11), was necessary as it was intended to become the new administrative center of the university.



Figure 10. Narrow windows.

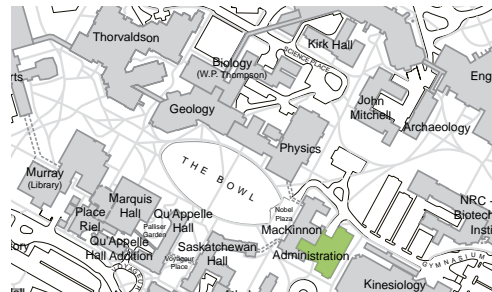

Figure 11. The location of the Administration Building is indicated in green on this contemporary campus map.

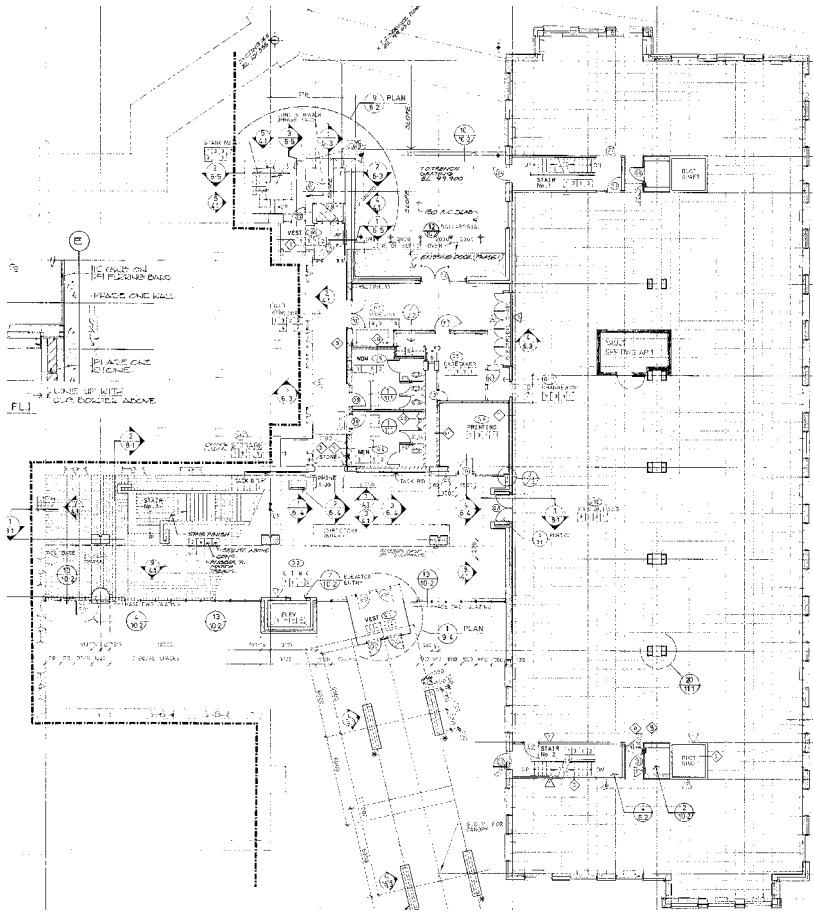

Figure 12. Original ground floor plan of the Administration Building. Retrieved from Facilities Management Division Asset Record System, File AB-671-AB.

2.4 Spatial Configuration

The Administration Building is a three-storey office building, each floor similar in layout. An east wing contains flexible office space (Figure 12), later fit out with demountable walls. The open plan of the office wing has allowed for its reconfiguration many times since the building's construction. The central wing connects the building back to the [MacKinnon Building](#), and houses the entrance lobby, a grand staircase, as well as services such as washrooms, storage, receiving and mechanical rooms. The building links to the MacKinnon Building on all three of its levels.

The three levels of the Administration Building are connected vertically by a central stair, located in a glazed atrium space (Figure 13). The atrium is built up against the former exterior wall of Convocation Hall, part of the MacKinnon Building, such that the old stone wall now forms an interior feature of the Administration Building. This strategy is repeated at many other locations throughout the building (Figure 14).

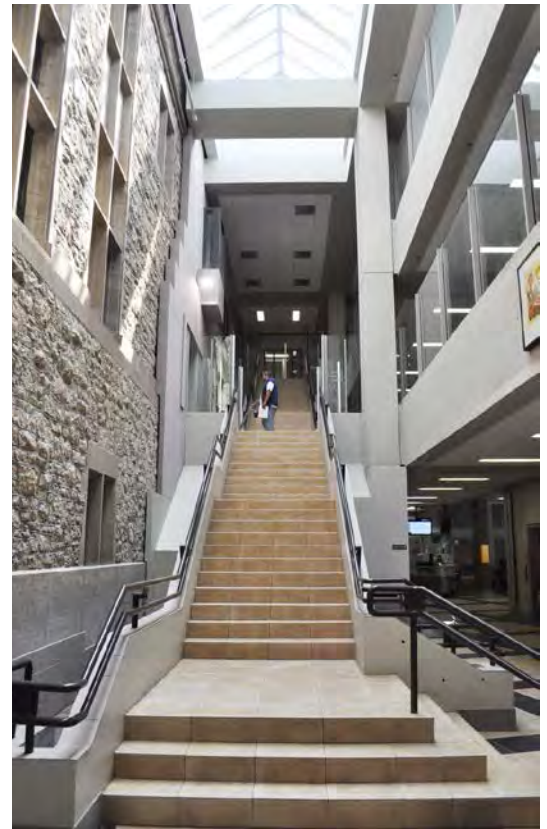

Figure 13. Central stair in the atrium.



Figure 14. Exterior wall of the MacKinnon Building enclosed in the Administration Building.



Figure 15. A perspective drawing of the 'arrival court.' A small outdoor courtyard was located to the left of the entrance canopy. Retrieved from Facilities Management Division Asset Record System, File AB-671-AB.



Figure 16. The Administration Building during construction. The concrete walls are visible. Photo A-7037, retrieved from http://scaa.usask.ca/gallery/uofs_events/articles/1956.php

As it was originally constructed, the entrance to the Administration Building was set back to form an exterior courtyard between it and the [MacKinnon Building](#). The courtyard was bisected by a walkway, covered in a triangular canopy, leading to the main entrance (Figure 7 & 15). In 1997, a large, triple height atrium was added to the north side of the building, enclosing the courtyard. A new paved forecourt with low stone walls was added to the north of the new addition.

2.5 Systems

The structural system of the Administration Building is a cast-in-place concrete frame and floors, except for the roof which is supported by steel. Figure 16 illustrates the building under construction with the concrete components exposed. The concrete exterior walls and columns are faced in greystone on the exterior, but are exposed on the interior. Exposed concrete also forms the structure of the central stair and the balustrades surrounding the atrium. The exposed concrete structure is a character-defining element.

2.6 Use(s)

The Administration Building was constructed with the purpose of accommodating the functions of the [MacKinnon Building](#), and houses administrative offices, meeting rooms, and some student services. With the structural failures that plagued the MacKinnon Building from 1979 until its restoration in 2005, a new facility was needed to become the administrative centre of the university. Most of the McKinnon Building was closed after the completion of the Administration Building in 1987. The Administration Building was built with large, open floor plans to allow for maximum flexibility. Figure 17 illustrates an open plan office in the Administration Building.

2.7 Cultural & Chronological Associations

The Administration Building can be associated with its designer, Clifford Wiens, Saskatchewan's most celebrated architect. Wiens was born near the community of Glen Kerr, Saskatchewan, in 1926. He studied agriculture at the University of Saskatchewan and art in Banff before his acceptance into the Rhode Island School of Design, where he studied architecture. In 1956, he began his forty year career as an architect in Regina. His architecture is marked by innovative solutions to structural problems, bold details and artistic composition of broad simple forms. During his career, Wiens was honoured with three Massey Medals. In 2011, Wiens received the Royal Architectural Institute of Canada's Gold Medal, in recognition of his significant contribution to Canadian architecture.

The Administration Building may be associated with the [MacKinnon Building](#). Built in 1912, the MacKinnon Building served for over seven decades as the administrative centre of the university. The Administration Building was commissioned to replace the older building when it was declared unsafe. When the MacKinnon Building was renovated and restored to use, the two buildings became physically and functionally linked.



Figure 17. Registrar's Office, September 22, 1987. Photo A-7049, retrieved from http://scaa.usask.ca/gallery/uofs_events/articles/1956.php



Figure 18. 1938 portrait of Walter C. Murray located in the Administration Building.

3. Associated Objects

The paintings of all former University Presidents are displayed in the Administration Building. The 1938 portrait of the university's founding President, Walter Murray, is shown in Figure 18. A large collection of other pieces of artwork from the university's art collection are also housed in the building. These pieces range in date from the early 1920's to the present and contain works by renowned Saskatchewan artists such as Allen Sapp and Dorothy Knowles.

4. Supporting Documents

Facilities Management Division (2012). Asset Resource Database [Data File]. Retrieved from \\usask\fmddfs\files\iis\IIS_Public\ARS.

University of Saskatchewan Archives. (Retrieved 2012). *Campus Buildings: New Administration Building*. Retrieved from http://scaa.sk.ca/gallery/uofs_buildings/



5. Summary of Character - Defining Elements

Materials

- greystone walls
- Tyndall stone trim
- exposed concrete interior walls
- painted steel balustrades
- brass door hardware

Form & Style

- 3-storey scale
- abstracted ornamentation
- elements referencing historical forms in a simplified manner

Location

- original location as an addition to the MacKinnon Building

Spatial Configuration

- link to MacKinnon Building
- open office plans
- main stair
- atrium & skylight
- shared walls with MacKinnon Building

Systems

- exposed concrete structure

Uses

- administrative functions

Cultural & Chronological Associations

- Clifford Wiens
- MacKinnon Building



008

Qu'Appelle Hall



008

Qu'Appelle Hall

Alternate Names

'New' Residence
Second Residence
Kelsey

Architect(s)

David R. Brown and Hugh Vallance, Brown and Vallance Architects, Montreal

Builders

Smith Brothers and Wilson, General Contractors

Construction Dates

1914-1916

Recognition

University of Saskatchewan 'A' Listed



Figure 1. Indiana limestone trim on a 'greystone' wall.



Figure 2. Granite steps.

1. Statement of Significance

Qu'Appelle Hall was the second residence hall built at the University of Saskatchewan. It is an excellent and characteristic example of Collegiate Gothic architecture, although the full scope and detail of the original design were never realized. Begun in 1914, Qu'Appelle was constructed during the First World War. The unfinished character of the building reflects the time period in which it was built and contributes to its heritage value. Qu'Appelle Hall was planned as part of the 1909 Master Plan, and its orientation on campus is integral to the framing of several courtyards intended by architects Brown and Vallance. Additions were carried out in 1962 by Izumi Arnott & Sugiyama Architects Ltd., and renovations by Melvyn Malkin Architect took place in 1972. The additions are beyond the scope of this report.



Figure 3. Qu'Appelle Hall as viewed from the 'Bowl' in 1923. Note that the Bowl is in the process of being landscaped. Saskatchewan Hall is visible to the left. Photo A-735, retrieved from http://scaa.usask.ca/gallery/uofs_buildings/

2. Character - Defining Elements

2.1 Materials

Qu'Appelle Hall closely followed the first wave of construction at the university, and was designed with a similar palette of materials to those of the [MacKinnon Building](#) and [Saskatchewan Hall](#). The primary exterior material is rough-faced 'greystone'. Cut stone trim and ornamentation is in Indiana Limestone (Figure 1), a subtle change from the MacKinnon Building and Saskatchewan Hall, where sandstone was used for this purpose. Granite was used for exterior staircases (Figure 2), although a concrete ramp has been poured over the granite stairs at the north-east entrance. Granite was also used as a base course for the exterior walls. (For further information on building stones used at the U of S, refer to ['Appendix: Stone.'](#))

Exterior doors on Qu'Appelle Hall are made of oak with inset glass. Other materials include slate roof tiles, copper drainage hardware and exposed wooden rafter ends. On the west façade, a series of ornate painted steel balconies distinguish the building from its predecessors (Figure 4). All of the original exterior materials are character-defining elements.



Figure 4. Steel brackets supporting a balcony on the west side of Qu'Appelle Hall.

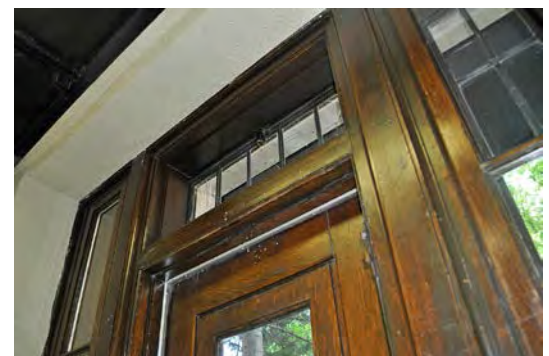

Figure 5. Oak window and door surrounds, steel framed sidelites.



Figure 6. The uppermost staircase: iron treads, stringers and balustrade, oak banister.

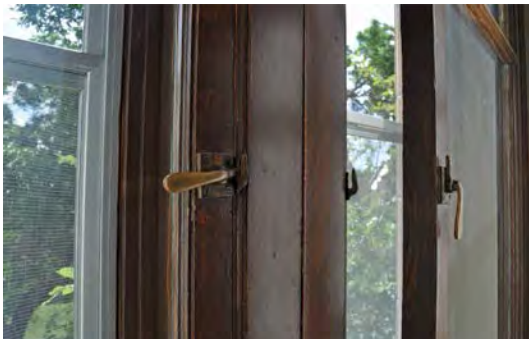

Figure 7. L to R: aluminum framed window, oak window surround, brass hardware, original wooden framed glazing.

Oak is a primary interior material, used for doors, door transoms, windows, door and window trim, stair handrails, fireplace surrounds and decorative trim. Stair balustrades are constructed of steel and iron (Figures 5 & 6). Door and window hardware is brass. Originally the interior doors featured glazed transoms. These have all been replaced with a metal panel save for a few doors in the basement and exterior (Figure 5). Windows are single-glazed and framed in oak. The original storm windows have been replaced by permanently affixed aluminum framed storm windows with screens (Figure 7). The original oak features are character-defining elements.

Although rarely used in other early University of Saskatchewan buildings, marble is employed quite heavily in Qu'Appelle Hall. Stair treads and landings and window sills are typically made of marble. A few marble baseboards remain. Marble is also found in combination with terrazzo as a flooring material in the basement. As Figure 8 illustrates, the former pool deck was finished in marble and terrazzo. The marble is white in colour and is generally in good condition, however, some of the marble landings have cracked. Some of the marble has been replaced by a locally available green marble that is also found in Saskatchewan Hall (Figure 9).

The walls of this building were originally painted plaster. They have been stippled in the public spaces and covered with wallpaper inside the residence rooms. Most of the floors were originally wooden, but in 1972, concrete floors were installed and were finished in carpet. Ceilings have been altered with the addition of suspended ceiling tiles throughout the public corridor spaces.



Figure 8. Marble and terrazzo located around the former pool. Both show evidence of having been painted.

Qu'Appelle Hall has three fireplaces that are visible and several others have been concealed within walls. As Figure 10 shows, these feature oak surrounds and brick hearths. The fireplaces are character-defining elements.

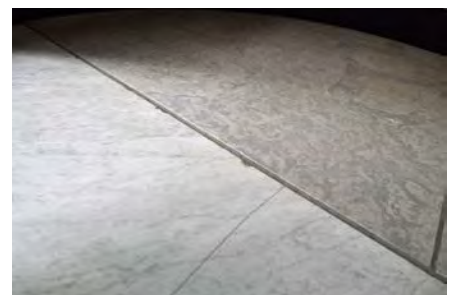

Figure 9. L to R: cracked original white marble, green replacement marble.

2.2 Form & Style

In plan, Qu'Appelle Hall was designed as a C-shaped building, opposite [Saskatchewan Hall](#) and forming a courtyard, now called [Voyageur Place](#), between the two buildings. In the 1909 Master Plan, Qu'Appelle Hall figures essentially as the mirror-image of Saskatchewan Hall, but in the detailed elaboration of its design, and in the extent of its completed form, several differences developed. Ranging from three to four storeys above grade, it was designed to be one storey taller than Saskatchewan Hall. It was also never built to completion as its original plans intended. Its north-west wing was not constructed, and a kitchen and servants' quarters were similarly postponed or abandoned. Figure 11 shows the areas that were constructed, in relation to the original plans. Figure 12 is a sketch of the building, including the unbuilt portions, as conceived by the architects. Qu'Appelle Hall was also intended to feature extensive carved stone decoration, as indicated in the drawing in Figure 13, but much of this was never completed. Figure 14 shows stone blocks around the arched stone entries that were prepared for decoration but never carved. The building may have gone unfinished due to the interruption of the First World War and its effects on the manpower of the construction industry and the finances of the university. (See also section 2.7)



Figure 10. Oak mantelpiece and brick hearth.

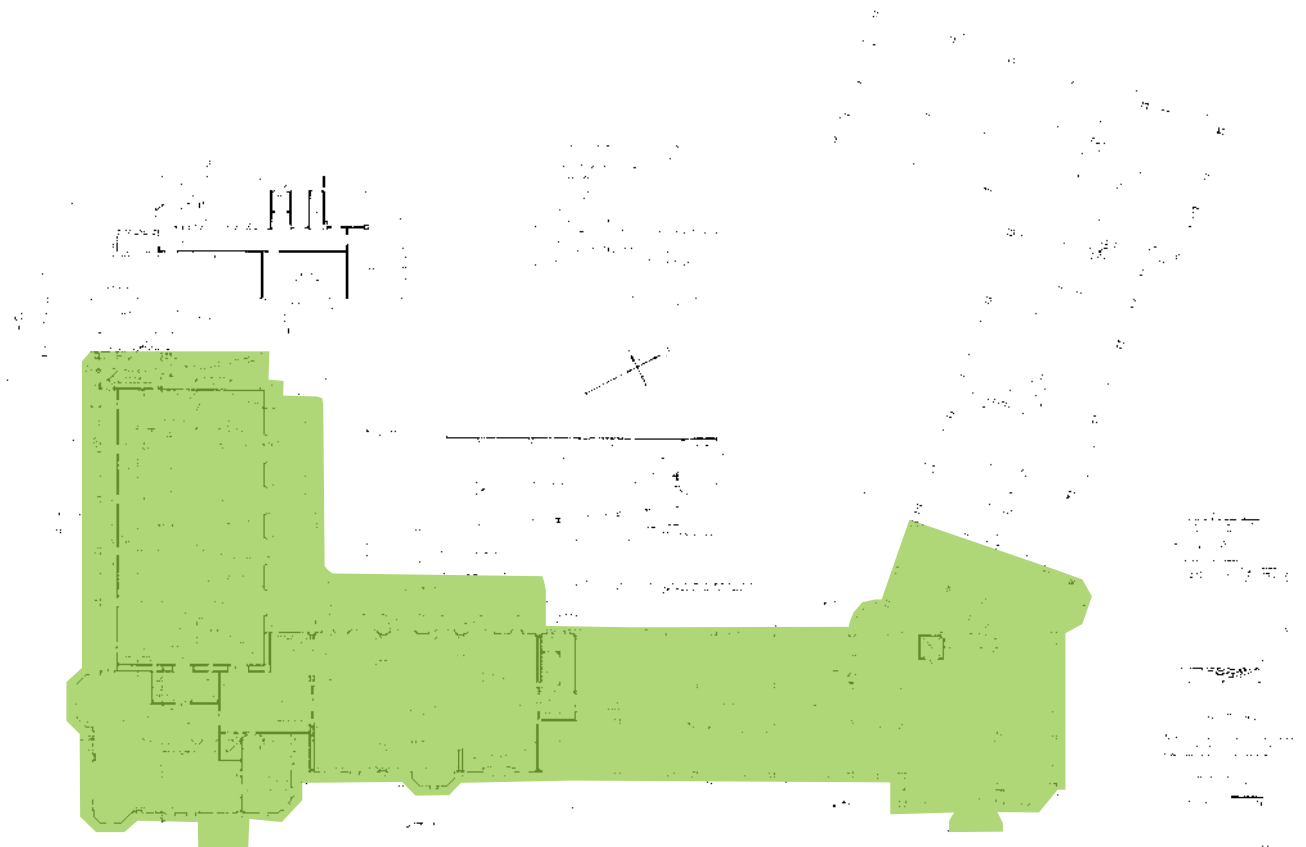

Figure 11. Basement floor plan. The portion which was built is indicated in green. North is to the right. Retrieved from Facilities Management Division Asset Record System, File Q-32-T.

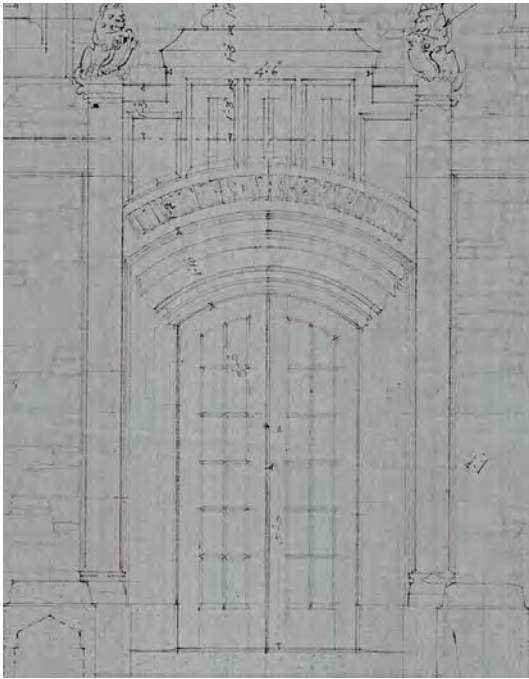

Figure 13. Plans for Qu'Appelle Hall: cut stone reliefs and statuary. Retrieved from Facilities Management Division Asset Record System, File Q-3-T.



Figure 12. The intended form of Qu'Appelle Hall as portrayed in a sketch by Brown and Vallance Architects for the construction firm, Richardson Builders, ca. 1909. Photo A-3751, retrieved from http://scaa.usask.ca/gallery/uofs_buildings/



Figure 14. Stone blanks above an entrance, intended for carved decoration.

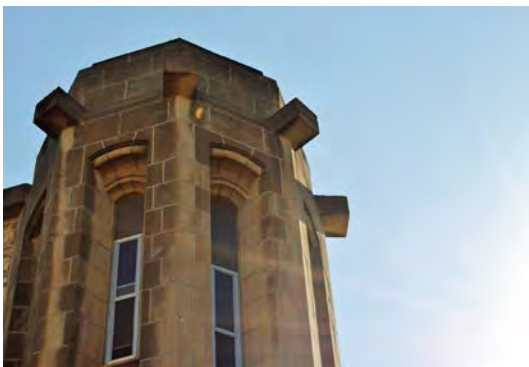

Figure 15. A turret with limestone protrusions and narrow archer style windows.

Qu'Appelle Hall is an excellent example of Collegiate Gothic architecture, despite its incomplete ornamentation. Its elevations are playful, asymmetrical compositions featuring gabled walls, projecting oriel windows, pointed arches, turrets and towers. Gabled dormer windows punctuate the roof line. On the south elevation, tall arched windows adorned with limestone tracery indicate the former location of a dining hall. The south-west and north-west corners of the building are marked by turrets, with narrow archer-style windows, containing circular stairs (Figure 15). Stone piers between the tall windows on the southern façade reference those of gothic churches (Figure 16). Indiana limestone string courses punctuate the façade on all sides of the building. On the west façade facing [Palliser Garden](#), arched door and window openings and ornate painted steel balconies overlook the courtyard (Figure 17).



Figure 16. A gothic arched window with tracery and spandrels.



Figure 18. Qu'Appelle Hall is highlighted in green on the 1909 Campus Plan. The yellow spaces show outdoor quadrangles which Qu'Appelle Hall helps to form. North is to the left.

2.3 Location

Qu'Appelle Hall helps to define three outdoor courtyards: [‘The Bowl’](#), [Palliser Garden](#) and [Voyageur Place](#). As indicated in Figure 17, Qu'Appelle Hall is located with its north façade facing The Bowl. Its east side frames the courtyard now called Voyageur Place. Along with Marquis Hall, Qu'Appelle forms an outdoor courtyard known as Palliser Gardens to its west. The shape and scale of this and other buildings of the period were carefully arranged to define intimately scaled outdoor spaces. The Campus Plan of 1909 was as much a landscape plan as it was a plan for the arrangement of buildings, and the campus was conceived by its architects as a landscape

of interconnected courtyards. The courtyards formed by Qu'Appelle Hall are therefore important character-defining elements, and its scale, material quality and detail are important features of these outdoor spaces.

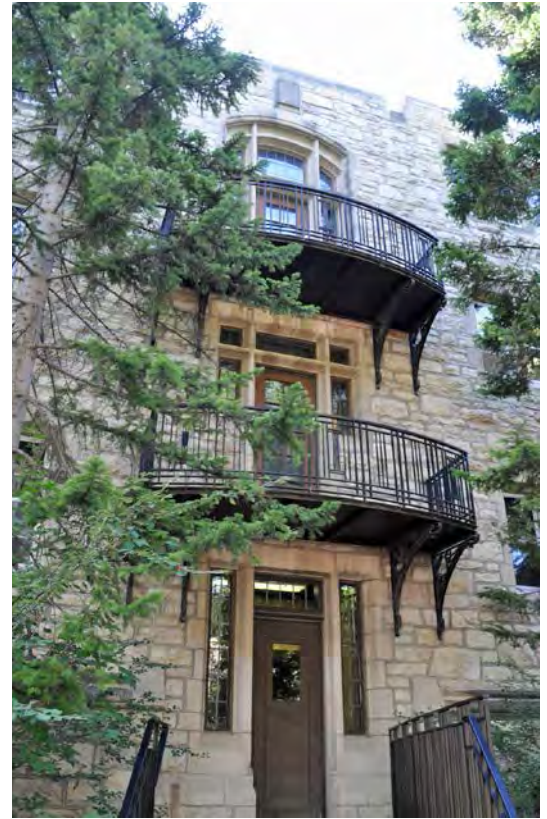

Figure 17. Ornate steel balconies on the western face of the building.

2.4 Spatial Configuration

Most of Qu'Appelle Hall is organized as a series of residential rooms arranged along double loaded corridors (Figure 19), except for the south wing, which originally accommodated larger spaces such as a dining hall on the ground floor and a swimming pool in the basement.

This south wing has been substantially reconfigured over time. Its basement originally accommodated a common room, dressing room and a pool (Figures 11 & 20). The common room featured two fireplaces and ground level windows to let in natural light. One of the fireplaces, shown in Figure 10, was designed with oak seating and an intricate brick hearth. This fireplace and seating has been preserved and its commemorative integrity is intact. The configuration of the former pool and dressing rooms has been preserved, but their uses have not. The pool itself was drained in 1972 and filled with concrete in 1980. On the ground floor, the south wing was originally configured as a dining hall; a grand space, two storeys tall, with high windows to the north and south and fireplaces at either end (Figure 21). From the outset, however, the dining room was not used for its intended purpose. It was used initially as a gymnasium and was later subdivided for a number of other purposes (Figure 22).

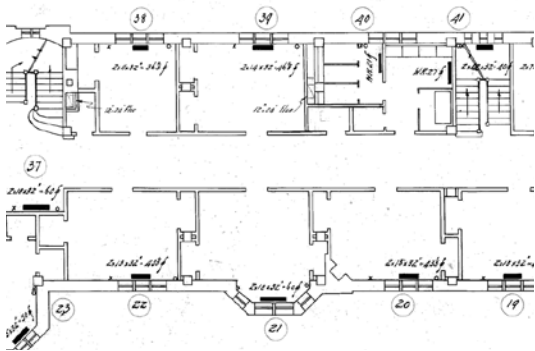

Figure 19. A portion of the original ground floor plan. North is to the right. Retrieved from Facilities Management Division Asset Record System, File Q-17-T.



Figure 20. A photo of the pool in the basement of Qu'Appelle Hall as it appeared in 1955-56. The photo was taken during a 'girls swim meet.' Photo B-556, retrieved from <http://www.usask.ca/greenandwhite/issues/2002/winter2002/features/feature06.php>

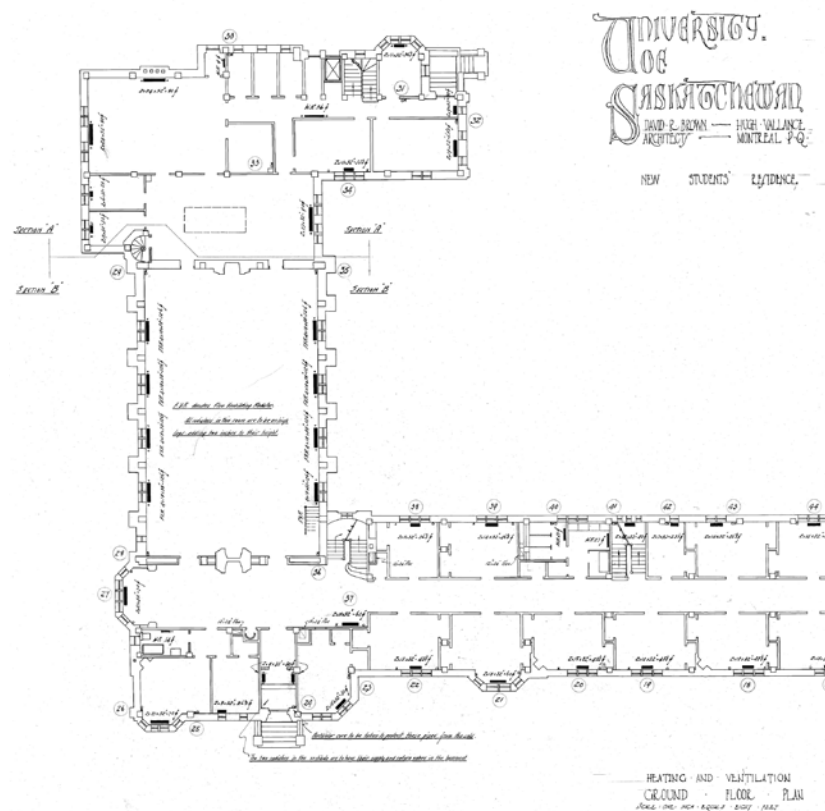

Figure 21. The original layout of the south end of the ground floor. The large open space was a dining room with two fireplaces. North is to the right. Retrieved from Facilities Management Division Asset Record System, File Q-17-T.

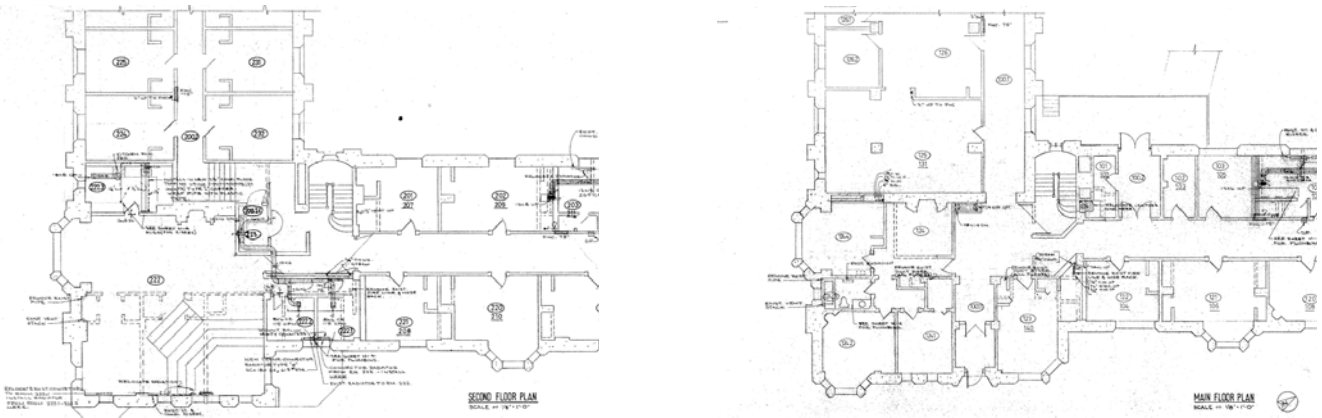

Figure 22. 1972 renovations to the south wing. L to R: the second floor plan, the main floor plan. North is to the right. Retrieved from Facilities Management Division Asset Record System, File Q-271-AB.

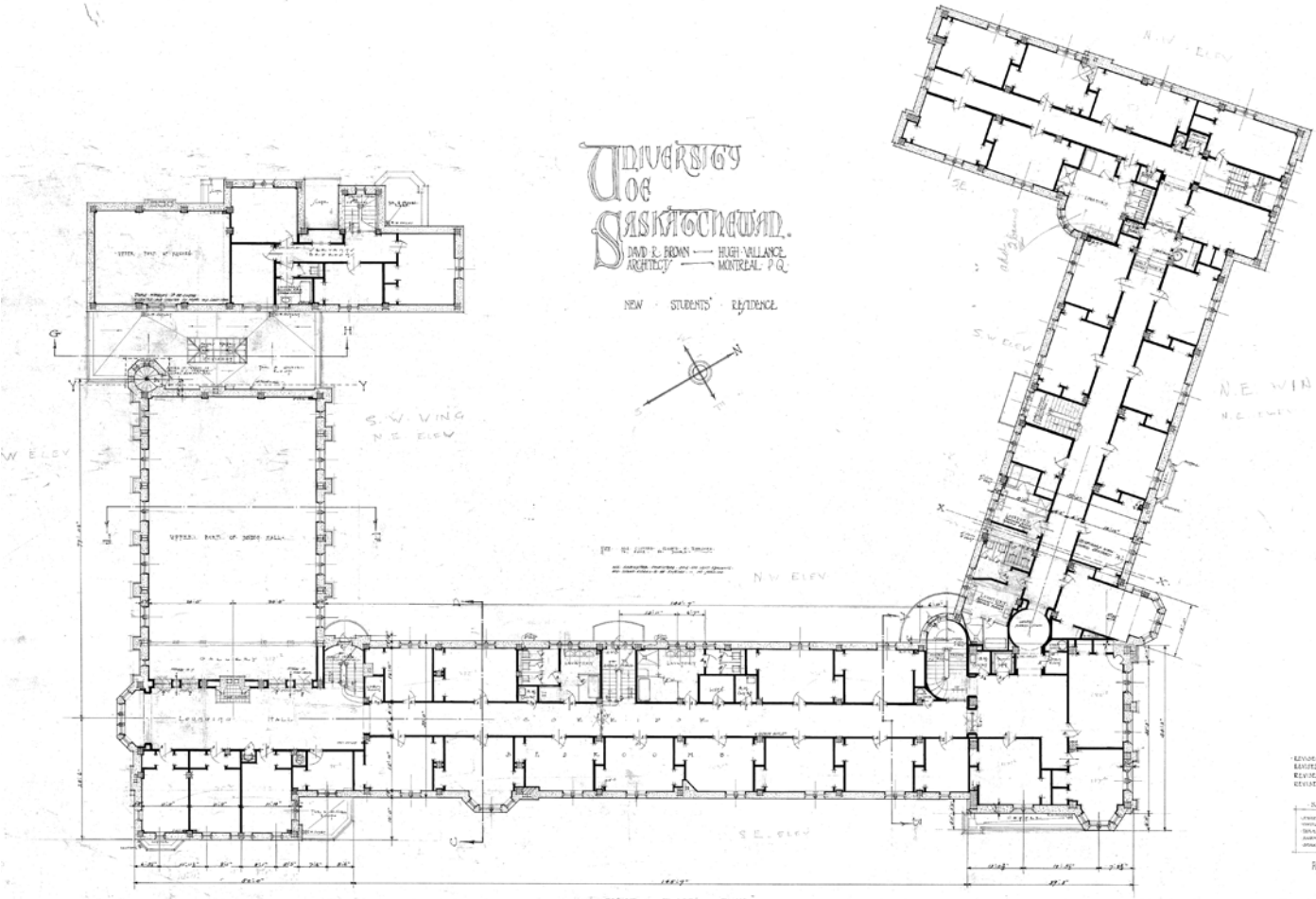

Figure 23. The original second floor plan shows an open space above a dining area and a lounge hall. North is to the right. Retrieved from Facilities Management Division Asset Record System, File Q-30-T.



Figure 24. The Qu'Appelle Hall gymnasium ca. 1930. Photo A-8028, retrieved from http://scaa.usask.ca/gallery/uofs_students/image_detail_decade.php?image=a-8028



Figure 25. Lounges in Qu'Appelle Hall where the former 'dining hall' existed. Photo A-3523, retrieved from http://scaa.sk.ca/gallery/uofs_buildings/.

The second floor of the south wing was once the open space above the dining hall. This wing has been renovated by the insertion of a floor plate, and is now known as 'Church,' owing to the gothic arched windows of its rooms. A comparison of Figures 22 and 23 demonstrate the changes made to this portion of the building.

The third floor of the south wing has become known as 'The Rafters.' The rooms here are named for their high, slanted ceilings that take the shape of the roof directly above. These rooms look out of the dormer windows that puncture the roofline of the south wing. Formerly, these rooms were accessible only by a spiral staircase in the turret on the building's south west corner. This spiral staircase was removed as part of renovations in 1972, and the 'Rafters' are now reached by new stairs added at either end of the hall.

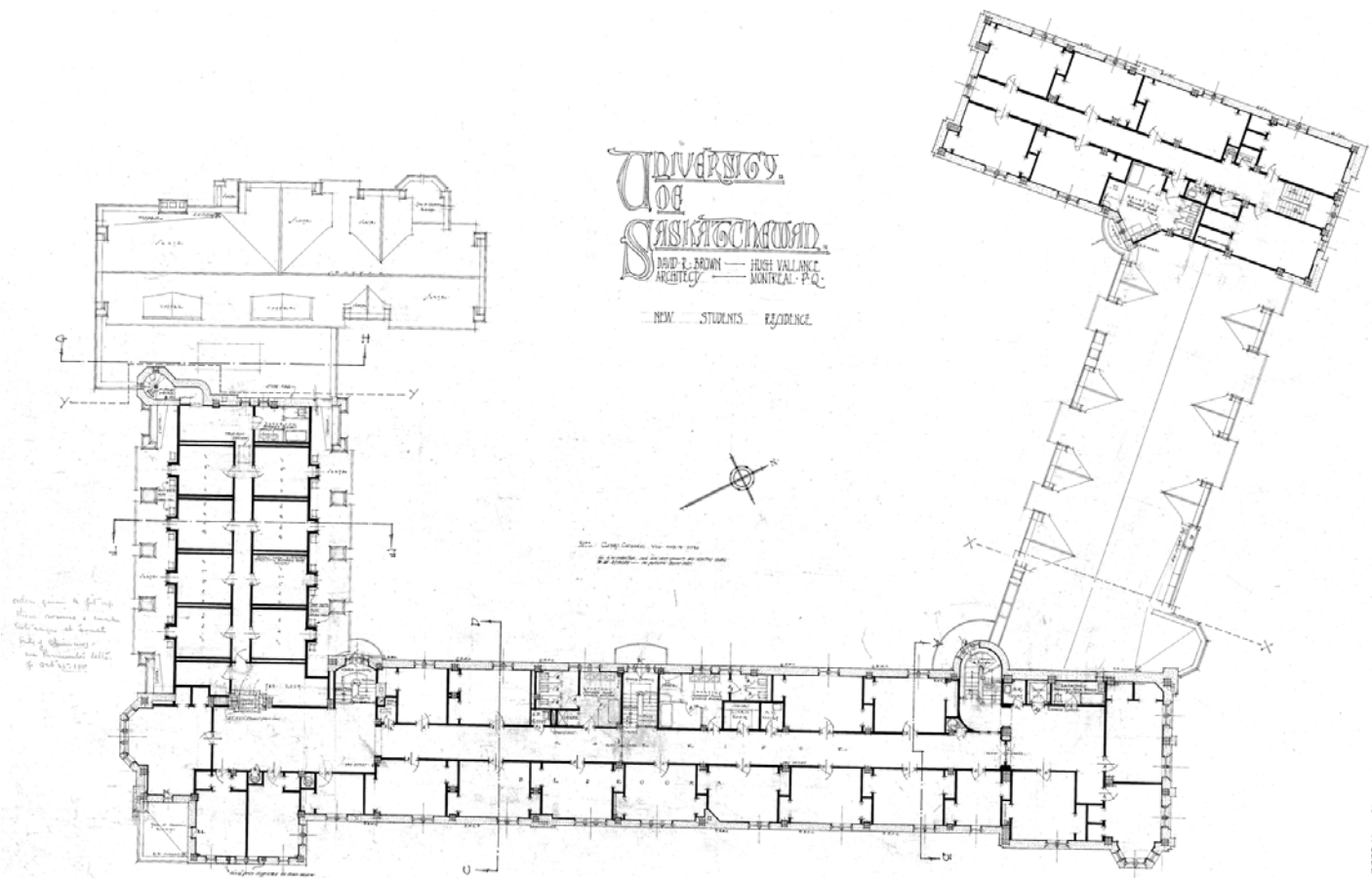

The north wing of the building has almost completely maintained its original configuration. On the ground floor, the layout of the interior residence rooms has been preserved. Slight changes have been made to the interiors of some of the rooms: fireplaces have been enclosed in the walls of several ground floor residence rooms. The south east corner of the ground floor has been converted into an apartment style residence enclosing the bay window that once allowed sunlight into the south end of the ground floor corridor.

The second and third floors of the building have also retained their original double loaded configurations. Served by three stairwells, the rooms all adjoin a spacious hallway. At the southern end of the hall a bay window allowed light into an open area with a fireplace. The bay window featured a built-in gathering area that has been maintained. Renovations have removed the three southernmost rooms with the effect of creating a large lounge with a kitchenette and a set of washrooms. The fireplace and bay window have both remained, however, they have been enclosed in a TV lounge.

The fourth floor of Qu'Appelle Hall is known as the 'Tower,' and is no longer used because it is served by only one staircase, and therefore does not conform to the current fire code. This area consists of a suite of four rooms in the north east corner of the building.

Figure 26. Original third floor plan. 'The rafters' are in the upper left (south west) corner, accessible here only by the turret staircase. North is to the right. Retrieved from Facilities Management Division Asset Record System, File Q-29-T.

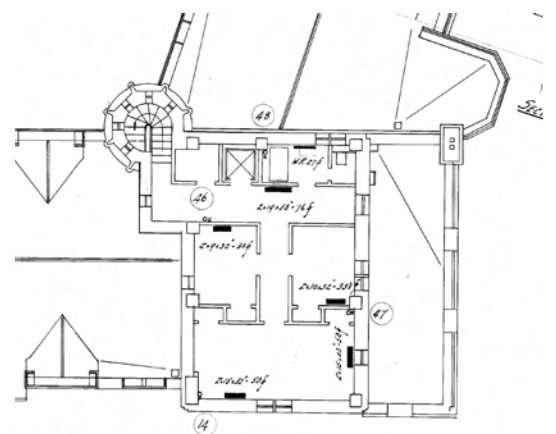

Figure 27. 'The Tower' as it was originally configured. It has since been divided into residence rooms. Retrieved from Facilities Management Division Asset Record System, File Q-14-T.

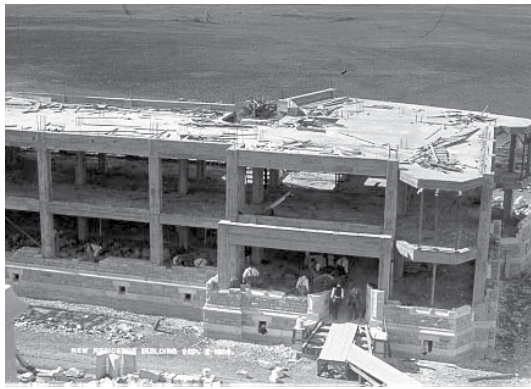

Figure 28. Qu'Appelle Hall under construction, September 2, 1914. Photo A-721, retrieved from http://scaa.sk.ca/gallery/uofs_buildings/.



Figure 29. A womens' diving competition held at the Qu'Appelle Hall pool ca. 1955-1956. Photo A-1064C_1, retrieved from http://scaa.usask.ca/gallery/uofs_students/image_detail.php?image=a-1064c.1

2.5 Systems

The original structure of Qu'Appelle Hall consists of cast-in place concrete slabs supported by concrete beams and columns. The roof rafters are wooden, and are supported by the concrete frame. The exterior walls of Qu'Appelle Hall are of stone, supported on concrete foundation walls and footings. At the exterior stone walls, the concrete structure is buried within the masonry construction and is not visible, but is evident in photographs taken during construction (Figure 28). This early concrete structure proved problematic, and in 1972, an extensive rehabilitation project was undertaken to reinforce it. Excessive deflection in the concrete beams was addressed by the addition of steel supporting columns at the midspan of each structural bay. An additional structural concrete slab was poured over top of the existing one both to strengthen it and to level the floors, which had sagged due to structural deflection.

2.6 Use(s)

Qu'Appelle Hall was built to function as a residence hall and still functions in this capacity. Other functions within the building have seen some change.

The basement of Qu'Appelle Hall used to house a swimming pool (Figure 29). The pool was 18 feet wide, 45 feet long and about 8 feet deep with a spring diving board. For several years after the pool was shut down the change room area was used as a gym. The pool has since been filled in and the room is now used as storage for the book store. The ground floor of Qu'Appelle Hall was built with a dining hall. From the outset, the spacious, naturally illuminated room was used as a gymnasium (Figure 24). Subsequent renovations converted the space into study lounges and meeting rooms.

The third floor, often referred to as the 'Tower', is in disuse. Traditionally the area housed staff and then residents. It has become uninhabited due to fire safety issues.

Because Qu'Appelle Hall has functioned continuously as a residence hall, its original spatial configuration has remained substantially unaltered, and its commemorative integrity is generally intact.

2.7 Cultural & Chronological Associations

The configuration of Qu'Appelle Hall, and its uninterrupted history as a residence hall has contributed to a strong sense of place. Different wings and floors have become nicknamed, often according to their unique spatial attributes. The places that have evolved within Qu'Appelle Hall include 'Kelsey,' the 'Rafters,' 'Church,' and the 'Tower.' Kelsey refers to the central portion of the building. The rooms in 'Church' have gothic arch shaped windows with tracery, which were formally the upper windows of the dining hall. The rooms in 'The Rafters' have sloped ceilings and dormers. The 'Tower' is so named for its form and for the single staircase which serves it.

As discussed in Section 2.2 above, the unfinished character of Qu'Appelle Hall associates it with the First World War.

3. Supporting Documents

Author Unknown. (Spring 2002). From Polo to Parties. *Green and White*. Retrieved from <http://www.usask.ca/greenandwhite/issues/2002/spring2002/features/1021956733.php>

Author Unknown. (Spring 2013). Tell us your Swimming Pool Stories! *Green and White*. Retrieved from <http://www.usask.ca/greenandwhite/issues/2002/winter2002/features/feature06.php>

Facilities Management Division (2011). Asset Resource Database [Data File]. Retrieved from \\usask\fmddfs\files\iis\IIS_Public\ARS

Snell, G. Personal communication, August 12, 2011.

Heiber, K. (1984). *The Greystone Review '84: 75 Years of Students at the U of S*. Saskatoon: 1984.

Hayden, M. (1983). *Seeking a Balance: The University of Saskatchewan 1907-1982*. Vancouver: University of British Columbia Press.

Murray, D.R. & Murray, R.A. (1984). *The Prairie Builder: Walter Murray of Saskatchewan*. Edmonton: NeWest Press.

University of Saskatchewan Archives. (Retrieved 2011). *Campus Buildings: Qu'Appelle Hall*. Retrieved from http://scaa.sk.ca/gallery/uofs_buildings/

University of Saskatchewan Archives. (Retrieved 2011). *The Student Experience, Sports: In the Pool*. Retrieved from http://scaa.usask.ca/gallery/uofs_students/index.php?load=pool_1



5. Summary of Character - Defining Elements

Materials

- steel and iron balconies, balustrades and steps
- slate tile roofs
- copper drainage hardware
- 'greystone' walls
- Indiana limestone trim and

decoration

- granite stairs and base
- oak-framed windows and transoms
- quarter sawn oak doors, door surrounds, fireplace surrounds, and stair handrails
- marble floors, landings, stair treads and partitions
- terrazzo floors
- brick hearths

Form

- framing of outdoor courtyards
- narrow floorplates
- 3-4 storey scale
- pitched roofs & gables

Style

- arched windows, entries, doors and fireplaces
- stone quoins
- stone string courses
- slate tile roof
- dormer windows
- archer windows
- spandrels
- decorative drainage spouts
- gothic arch windows and doors
- stone tracery
- turrets
- exposed rafter ends
- decorative balconies
- stone piers
- vaulted ceilings
- arched transoms
- crenellated parapet
- bay & oriel windows
- faux balconies
- carved stone brackets

Spatial Configuration

- narrow footprint
- double loaded corridors
- turrets
- wide corridors
- high ceilings in upper floor rooms and ground floor corridor
- formation of outdoor courtyards

Uses

- student residence
- swimming pool
- 'dining hall' gymnasium

Cultural & Chronological Associations

- unfinished cut stone ornaments
- First World War



009

Physics Building



009

Physics Building

Alternate Names

Science Building

Architect(s)

David R. Brown and Hugh Vallance, Brown and Vallance Architects, Montreal

Builders

Smith Brothers and Wilson, General Contractors

Construction Dates

1919-1921

Recognition

University of Saskatchewan 'A' Listed

1. Statement of Significance

The Physics Building is a significant heritage building at the University of Saskatchewan, constructed between 1919 and 1921, and designed by the architectural firm of David Brown and Hugh Vallance of Montreal. It has heritage value as one of a collection of early stone buildings located around [‘The Bowl’](#), a large landscaped courtyard forming the heart of the campus. The Canadian Register of Historic Places has called this group of buildings “the finest collection of Collegiate Gothic university buildings in Canada.” The Physics Building was originally planned to be constructed as part of a second phase of buildings including a second residence, a chemistry building and an arts building. The Physics Building was approved in principle at an April 1914 meeting, at an estimated cost of \$100,000, but was delayed in favour of the residence and wasn’t tendered until November 12, 1914. By this time the First World War had begun and the Physics Building was postponed for another five years. Architect David Brown redesigned the Physics Building for lack of any other work to do in the office during these years of hardship.



Figure 1. Materials of the Physics Building: greystone complemented by Indiana limestone with a granite base.



Figure 2. The Physics Building as viewed from the Bowl in June, 1960. This photograph was taken before additions were made to either end of the building. Photo A-670, retrieved from http://scaa.sk.ca/gallery/uofs_buildings/

After the war, the Physics Building became a project of special concern for the university. President Walter Murray appealed to the Board of Governors, “in the strongest manner possible the urgency of the need for the Physics Building.” The need arose from a lack of laboratory and general classroom space; without the Physics Building, the university would have had to turn students away. In 1921 Murray’s concerns were assuaged and the Physics Building was completed according to the 1909 plan.

The Physics Building was situated such that it closed the northern vista of The Bowl, which was at that time surrounded by open prairie. Boasting the first real lecture theatre at the university, the Physics Building soon became used by all colleges and departments. The lecture theatre and classroom space gave the university the ability to grow and accommodate more students. The final sum of construction costs for the building was \$437,000.

Note: The Physics Building is configured with floors numbered Basement, First Floor, Second Floor and Attic. This report follows the same convention.



Figure 3. Main entrance to the Physics Building.

2. Character - Defining Elements

2.1 Materials

The exterior of the Physics Building was designed to match in style and materials the other buildings already constructed around [The Bowl](#). Its walls are constructed of local 'greystone', with Indiana limestone for cut stone decoration and window surrounds, and a granite base course (Figure 1). Granite was also used for the exterior steps leading up to the main entrance (Figure 3). The greystone walls of the Physics Building were built in the 'scotch masonry' style, with squared stones laid up in a more tightly coursed pattern than on the earlier [MacKinnon Building](#). The architect described the effect as "stiff and formal". The roof of the Physics Building features slate tiles. The stone façade of the Physics Building and its slate tile roof are character-defining elements. (For further information on building stones used at the U of S, refer to [Appendix: Stone.](#))

In the entry foyer, the original slate stair treads have been replaced by concrete steps. Both the exterior doors and the interior vestibule doors are in oak. On all the foyer walls brick is used to create arches supporting a vaulted plaster ceiling. Public corridors also feature brick wainscoting and arches with plaster walls and ceilings (Figure 25). Corridor floors are slate with inset red clay tile. Doors and door surrounds are quarter sawn oak, featuring glazed panels. The glazing of the panels features a character-defining frosted pattern that renders the panels translucent (Figure 5). Some of these glazed panels have been replaced with oak to obstruct the view between corridor and classroom; such is the case at the doors of the lecture theatre. Transoms are composed of three glazed lites. In some instances they have been replaced with a single lite or another material. Window frames are fashioned out of steel and where there are latches they are brass, as shown in Figure 6. Brass ventilation grilles, some painted, are found throughout the building. Cast iron radiators, although painted, are still found throughout the building (Figure 7).

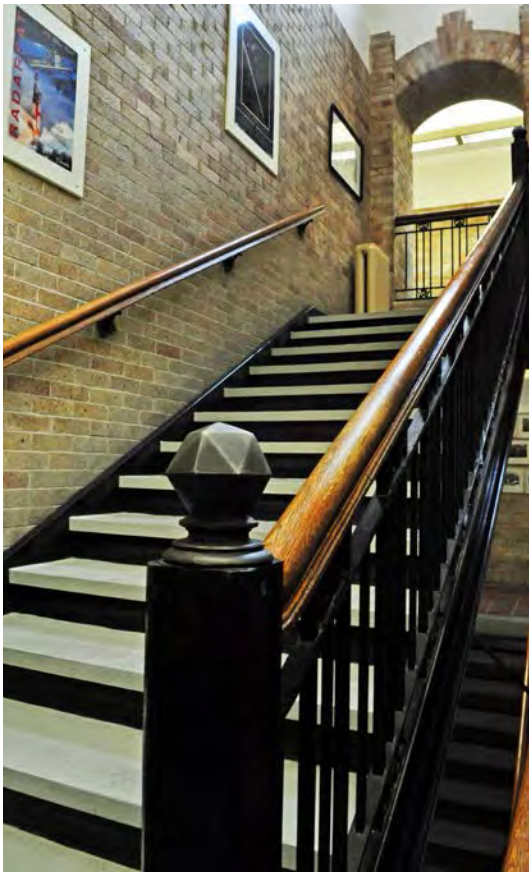

Figure 4. Main staircase: steel and iron balustrade and stringers, oak banister. The concrete treads are not original.



Figure 5. Patterned glazing in a quarter sawn oak door.

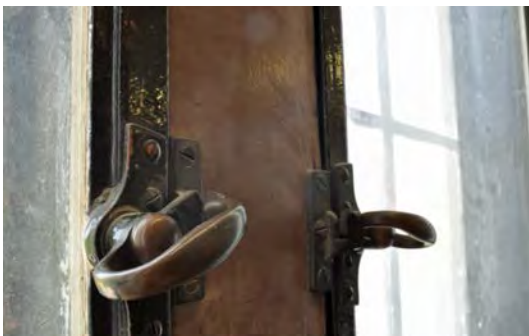

Figure 6. Brass window latches.



Figure 7. Cast iron radiator.

The main staircase in the Physics Building shares many characteristics with other early University of Saskatchewan buildings, such as the MacKinnon Building: slate treads, and oak handrails supported by steel and iron balusters (Figure 4). The commemorative integrity of the staircase is diminished by the fact that the treads between the ground and first floor have been replaced with concrete. The remaining original slate treads in the Physics Building were replaced with matching slate in 2012. Two secondary staircases also exist in the building: a narrow flight of stairs leading from the Second Floor to the Attic level and roof, and an interconnecting spiral stair between the Second storey and the Attic. Both of these secondary staircases are constructed of iron and steel (Figure 8).



Figure 8. Steel and iron staircase.

The third floor or attic features a material set completely different from the rest of the building. Shown in Figure 9, the walls appear to be made of painted wood as well as the doors. The floor is painted concrete and the original ceiling has been covered by a suspended acoustic tile system. Steel roof trusses, which form part of the roof structure, are also partially exposed in the attic level (Figure 10). (See Section 2.6 Systems).

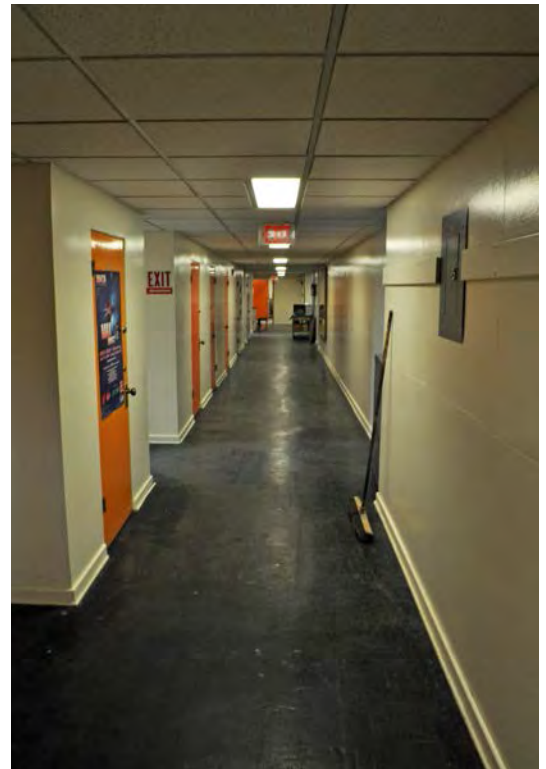

Figure 9. Attic corridor.

The lecture theatre (Figure 11) is a character-defining element, but many of its material finishes have been altered over time. The concrete risers and wooden tablet-arm chairs are original. The painted wood ceiling, painted wood wall panelling and acoustic panels on the walls and ceilings were the product of later renovations. The brick walls have also been painted. The original oak and slate chalkboard, although worn, has not been refinished. The original steel and iron balustrade is pictured in Figure 11. Overall, this room has a high level of commemorative integrity.



Figure 11. Lecture theatre: steel and iron balustrade and desk mounts, original windows and concrete risers.

The interiors of rooms



Figure 10. Steel truss.



Figure 12. Modern aluminum framed secondary glazing over the interior of the original windows.

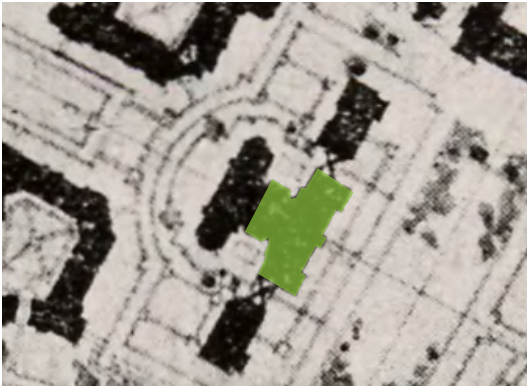

Figure 13. Plan view of the Physics Building. The original built portion is indicated in green. North is to the left.

now used for offices have been maintained to a high level of commemorative integrity although some alterations have been made. Flooring in many offices has been replaced by vinyl composite tile (VCT). Many doors between offices are no longer functional, however, in many cases they exist in their original state. Original wooden moldings are still in place near the ceilings although they have been painted. In many offices the original windows have been retrofitted with new aluminum framed secondary glazing (Figure 12). This method allows for the original windows to be kept, while improving their thermal performance. Many of the original large window and transom frames feature hinged blind covers. No original blinds are known to remain. (See Section 2.6 Systems).

2.2 Form

The Physics Building is a T-shaped building in plan, laid out with its primary axis parallel to the central axis of [The Bowl](#). Its secondary axis is laid out perpendicular to the first, aligned with the centre of The Bowl and protruding to the north of the building. The architects intended for the Physics Building to eventually take the shape of an H, with two hallways joined by lecture theatres at the centre. Figure 13 illustrates the original plan, and the form of the building as constructed in 1921.

The Physics Building as built functions as an enclosure, defining the northern edge of The Bowl. The height of the Physics Building includes a half exposed basement, two floors above ground and an attic. This makes the massing of the Physics Building consistent with the scale of the other buildings which ring The Bowl; an important factor in maintaining the pedestrian scale of the central campus.



Figure 14. View looking north at the Physics Building ca. 1962. (The Betatron addition had been made at this point but is not visible from this point of view). Photo A-10687, retrieved from http://scaa.sk.ca/gallery/uofs_buildings/

The form of the Physics Building has been added to over time. Figure 14 shows the original form. For a plan view of the original form refer to Figure 13. In 1948 the Betatron Building was built as a one storey addition accessible through the basement of the Physics Building. The Betatron Addition featured thickened concrete walls to contain the gamma rays being researched there. This addition also featured a small concrete chamber for gamma rays to be shot into and measured. The thickened walls of the chamber are shown in Figure 15. Between 1966 and 1967, an addition to the Physics Building was constructed to the south-east.

A similar modification was made to the building's form on the north-west where a link to the Geology Building has joined the two buildings, as seen in Figure 17.

These adaptations came to form a continuous building face that fully encloses the north side of The Bowl. All three additions change the commemorative integrity of the form of the Physics Buildings by adding to its massing; however, none of the additions have removed any of the pre-existing form. The 1966-67 Physics Addition and the Biology Building are beyond the scope of this report.



Figure 15. The betatron room.

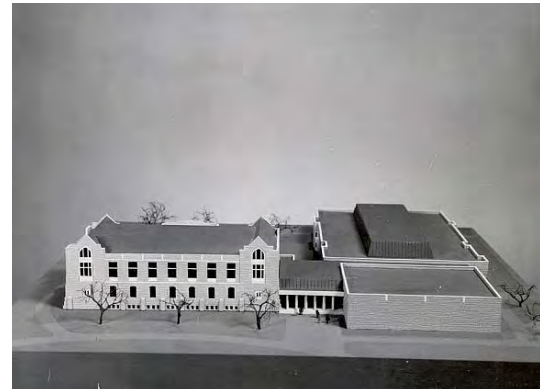

Figure 16. A July 1964 Architect's Model for the Physics Building Addition. Photo A-4381, retrieved from http://scaa.sk.ca/gallery/uofs_buildings/



Figure 17. L to R: the facades of the Geology and Physics Buildings.



Figure 18. A recessed, vaulted entryway with pointed arches is a Collegiate Gothic character-defining element. Other typical Collegiate Gothic decorative elements, such as grotesques, heraldry and reliefs are absent.

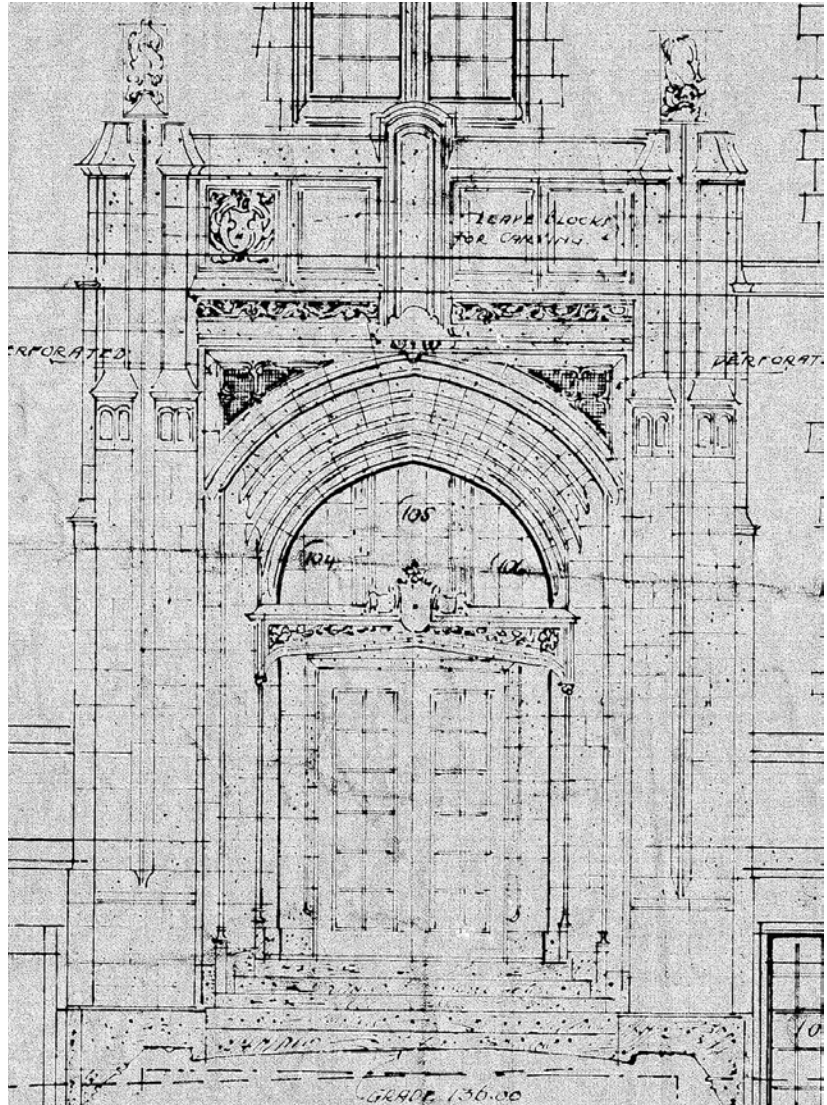

Figure 19. A drawing specifying ornamentation around the main entry. Retrieved from Facilities Management Division Asset Record System, File P-6-T.



Figure 20. Arched windows, stone piers and spandrels.

2.3 Style

With these additions to the Physics Building, none of the original stylistic elements of the building appear to have been altered; the original building maintains its Collegiate Gothic style with a high degree of commemorative integrity. While the Betatron addition, completed in 1948, largely blends in with its predecessor, the 1966-67 addition stands as a contrasting element from which the original Physics Building is easily discernible. The Geology Building sympathizes with the Physics Building, making use of greystone, bay windows and stone piers but is also a clearly differentiated building.

The exterior of the Physics Building features a number of elements associated with the Collegiate Gothic style. The main elevation, facing The Bowl, is composed of a row of windows on each of the basement, first and second floors, terminated at either end by a more prominent end bay. Both end bays feature a gabled roof line and a large double-height arched window opening (Figure 23). The central element of the façade is the main entrance, whose double doors are recessed within an intricately carved gothic vault. This recess is framed by Indiana limestone piers (Figure 18). A row of horseshoe arches in the form of tracery decorates the two piers (Figure 21). Further ornamentation was originally specified, but never carried out. Figure 19 shows this ornamentation in the form of carved stone statuary and reliefs, but the stone blocks intended to be carved still stand blank, awaiting decoration. Figures 18 and 21 both show the blank stonework that was intended to be decorated.

At the basement level, a series of Indiana limestone piers align with the structural frame. The first floor windows all have arched openings. The second floor windows are rectangular, and feature stone spandrel panels. The roof line is punctuated by a row of narrow decorative archer-slots. Figure 20 shows the basement level piers, the arched first floor windows, and the second floor windows and spandrels.

Collegiate Gothic elements are continued inside the building. The entrance vestibule features brick walls and arches, and a second set of oak doors, with an arched wooden transom. In the corridors, a brick wainscoting is extended to form brick archways around door openings (Figure 25). The doors also feature arched transoms. Many of the interior windows share this arched shape. Many secondary hallways feature vaulted ceilings and arched entries. Figure 22 shows some of these interior elements. The attic contains heritage value in the large arched windows of the two end bays, which are set at floor height and nearly reach the ceiling (Figure 30).

The staircases serving this building also contain character defining Collegiate Gothic elements. The central staircase features ornate cast iron and steel balustrades. An iron and steel balustrade featuring decorative finials adorns the second level of the main lecture theatre. These character-defining elements are discussed in the Materials section; refer to Figure 4.

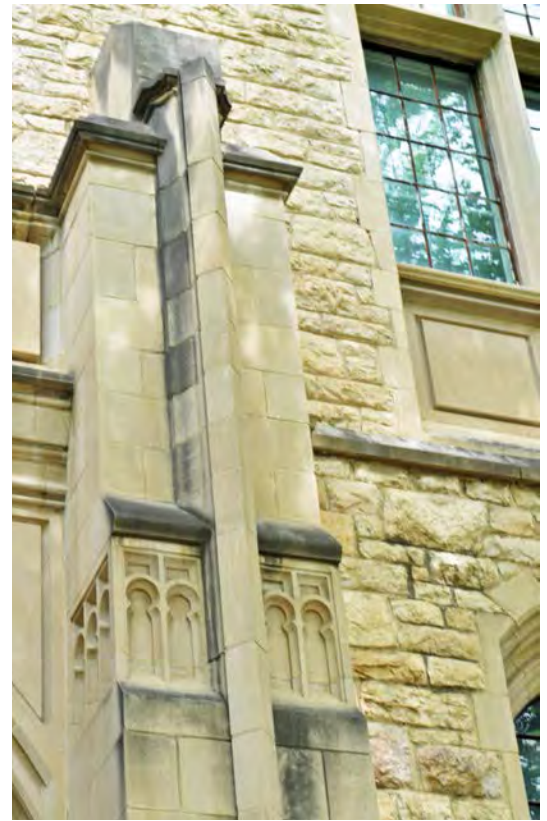

Figure 21. Horseshoe arch reliefs decorate either side of the main entry.

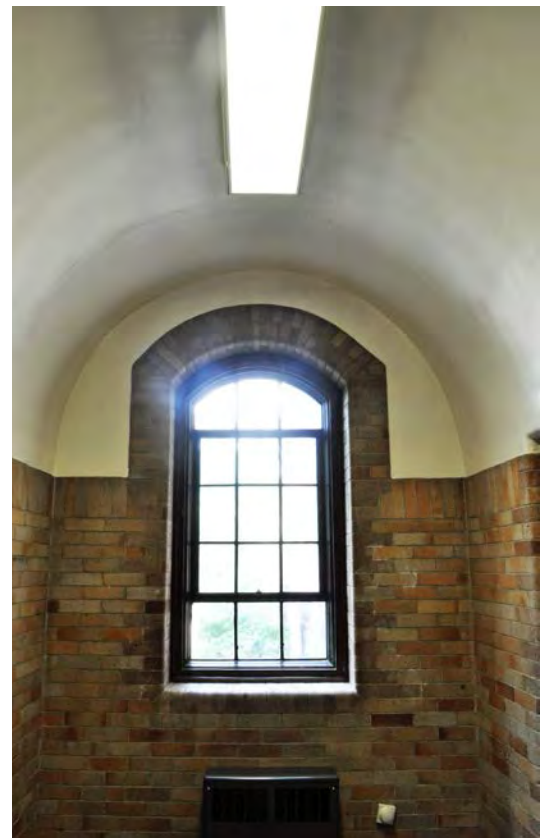

Figure 22. A vaulted ceiling and brick wainscoting.

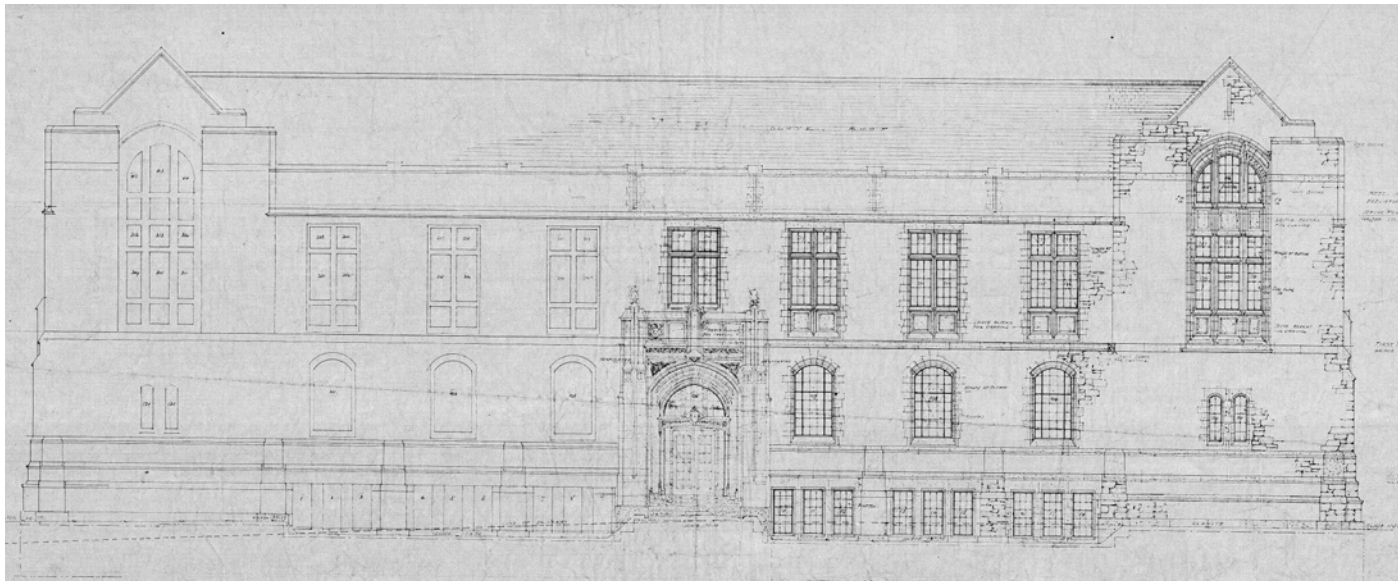

Figure 23. A 1917 elevation of the Physics Building. Retrieved from Facilities Management Division Asset Record System, File P-6-T.



Figure 24. The location of the Physics Building on the 1909 Campus Plan is indicated in green. North is to the left.

2.4 Location

The location of the Physics building is faithful to the 1909 Campus Plan by Brown and Vallance (Figure 24). In that plan, [The Bowl](#) is located at the intersection of two axes, which divide it into four quadrants. The Physics Building is centred on the secondary axis dividing The Bowl.

The Physics Building encloses the northern edge of The Bowl and sits directly parallel to it. A straight axis can be drawn from the grand entrance of the building to the outdoor quadrangle between Saskatchewan and Qu'Appelle Halls known as [Voyageur Place](#). The prominent location of the Physics Building has maintained its commemorative integrity and is a character-defining element.

2.5 Spatial Configuration

As discussed earlier, the Physics Building is T-shaped in plan. The longer bar form, which sits parallel to the central axis of The Bowl, was arranged on each of the basement, first and second floors as a series of rooms arrayed along a double-loaded corridor (Figure 26). These rooms contained laboratories, classrooms and offices. The second volume of the building, which extends from its north side, contained the larger space of the lecture theatre, which spans between the first and second floors.

Several changes have been made to the spatial configuration of the Physics Building. The main corridor on the ground floor no longer terminates in rooms at either end. With the continuation of the building into the Physics Addition on one side and the Geology Building on the other, the corridor has now been lengthened to become a conduit through the building rather than one for purely internal circulation. Figures 27 and 28 show the changes to the spatial configuration of the building on the east and west end of the corridor respectively.



Figure 25. The main corridor of the Physics building relies on electric light.

The basement's spatial configuration has been changed in a similar fashion. Figure 26 shows its original layout. The east portion of the basement has been reconfigured to connect to the basement of the Physics Addition. The large lab that Figure 26 shows at the end of the basement corridor has become an extension of the hallway. Figure 27 shows this change. The west end of the basement has not been extended.

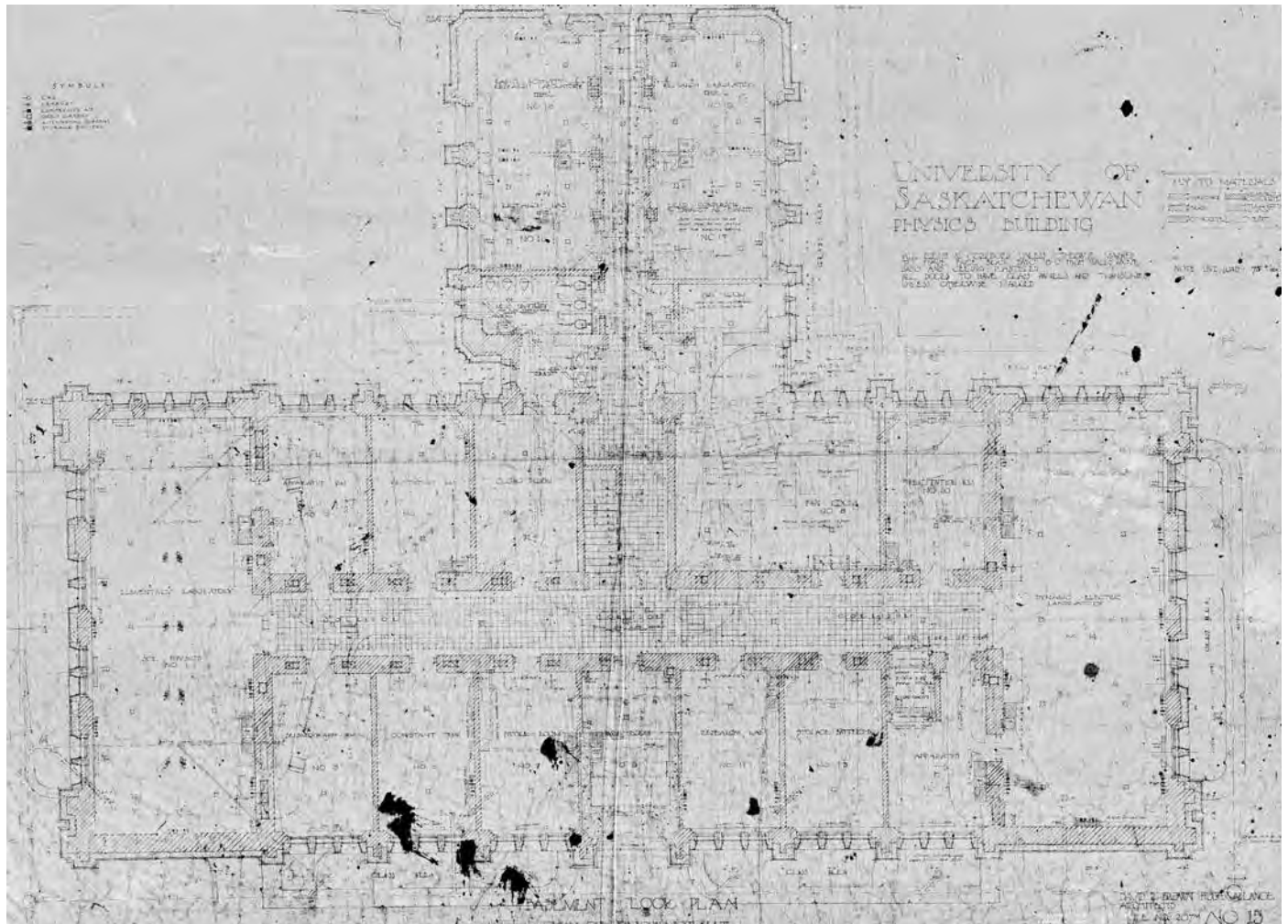

Figure 26. A 1917 basement floor plan shows labs at either end of the main corridor. Retrieved from Facilities Management Division Asset Record system, File P-10-T.

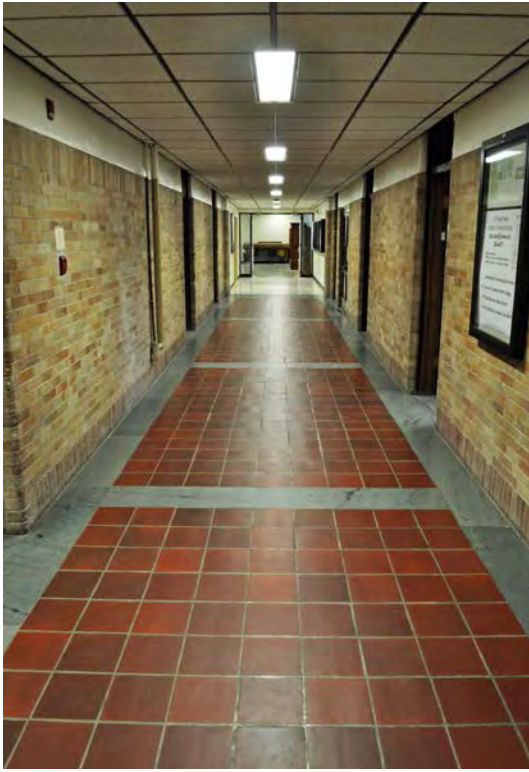

Figure 27. The main corridor features brick walls, terra cotta and slate floor tiles. A suspended ceiling tile system has obscured some of the transom windows above the doors.

The application of suspended ceiling tiles in the basement has reduced the height of these spaces. The ceiling in the northern portion of the building has not been covered. Where the dropped ceiling has been installed, some transoms have been partially obscured. Fluorescent lighting has been installed within the suspended ceiling tile system and now provides the majority of the light in the corridors.

The ground and second floors retain their high ceilings. The spacious dimensions of the corridors are a character-defining element. High ceilings also remain in many of the adjacent rooms. The tall windows that allow abundant daylight into these rooms have also been maintained, and contribute significantly to the character of these spaces.

The rooms in the attic space are also filled with daylight, owing to the large skylights and arched windows there. The skylights are original features, which retain their character and are useful in lighting offices, equipment rooms and labs. These skylights are important in defining the light and airy character of the attic. The exposure of the steel truss system, the high ceilings and sloped walls of the attic are all elements integral to the quality of this space (Figure 30).

As the university's first true lecture theatre, the double height lecture hall in the Physics Building is an important space in the history of the University of Saskatchewan. The space still holds great commemorative integrity in its tall proportions, large windows and steeply sloping risers. These tenets serve to enhance the perception of the height of the room and define it as the Physics Building's grand academic space. (See Figure 11 Section 2.1 Materials).

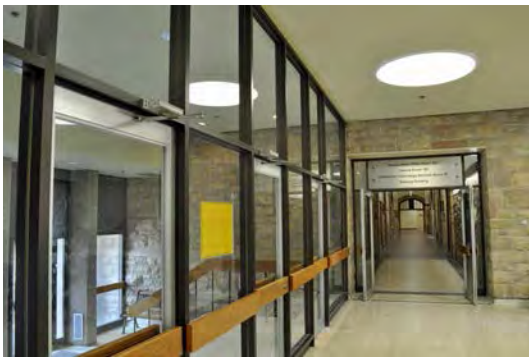

Figure 28. Lobby of the Physics Addition.

2.6 Systems

The primary structure of the Physics Building consists of cast-in-place concrete floors supported by load-bearing brick and stone walls at the exterior, and by two parallel brick walls on the interior. The floors are built in an unusual way, with cast-in-place concrete poured over and embedding hollow clay tile blocks. Figure 31 shows this unique flooring structure. Concrete beams support this assembly. The same clay tile and concrete structure was used in the [Thorvaldson Building](#) at the University of Saskatchewan, and in both cases reflects experimentation with concrete structures during the early years of their application.

The roof structure over the laboratory wing in the Physics Building consists of a sloped concrete slab with embedded steel I beam purlins on a system of steel trusses. Steel columns and a steel truss system support the roof structure as shown in Figure 30. The truss system spans the width of the roof and continues along the slanted walls created by the slope of the roof. The walls that have been added in the attic now conceal the steel column supports shown in Figure 30. The steel truss remains visible in the attic. The roof structure over the lecture theatre is a cast-in-place concrete slab with embedded steel I beam purlins.

A notable innovation in the Physics Building relates to the provision of electricity. Each work station was equipped with access to gas, compressed air, and both A/C and D/C power outlets. In fact all rooms were built with these conduits in case their conversion into physics labs became necessary. At the time of construction it was common practice for D/C power to be provided by means of a portable battery. The Physics Building was built with a large storage battery in the basement wired to a distribution panel so that electrical current could be transmitted to any room. This method was shown to be superior and attracted a lot of attention from other universities building physics labs in later years.



Figure 29. The west wall of the Physics Building now makes up part of the interior of the Geology Building.

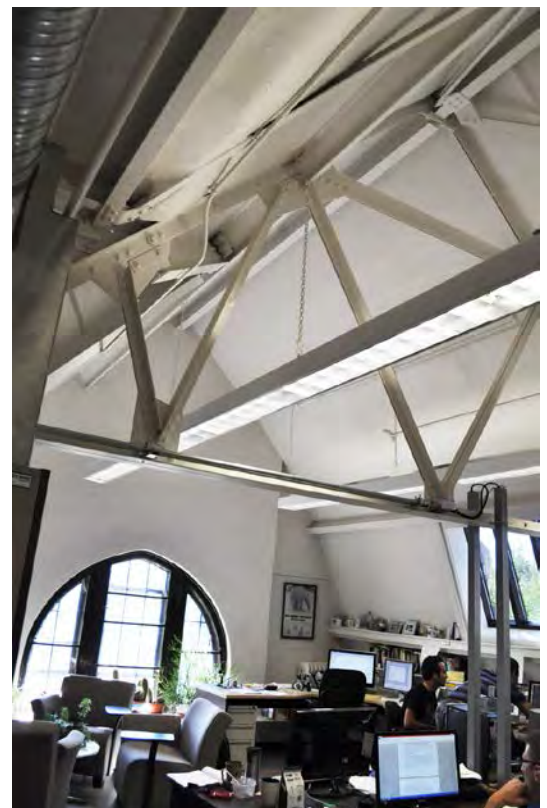

Figure 30. Attic: large gothic arched window, exposed truss and high sloped ceiling.



Figure 33. Fire hose carrier.



Figure 34. Hinged oak valance.

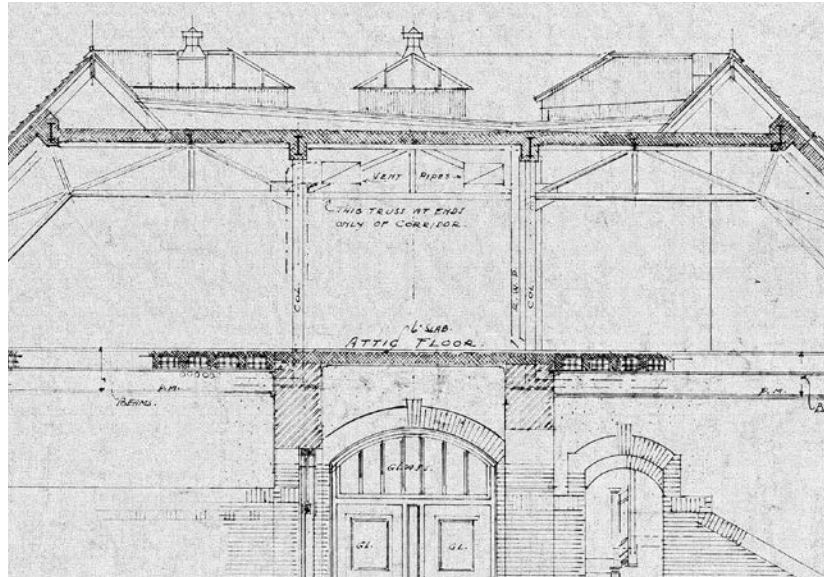

Figure 31. A 1917 section shows the roof structure of the Physics Building. Retrieved from Facilities Management Division Asset Record System, File P-2-T.

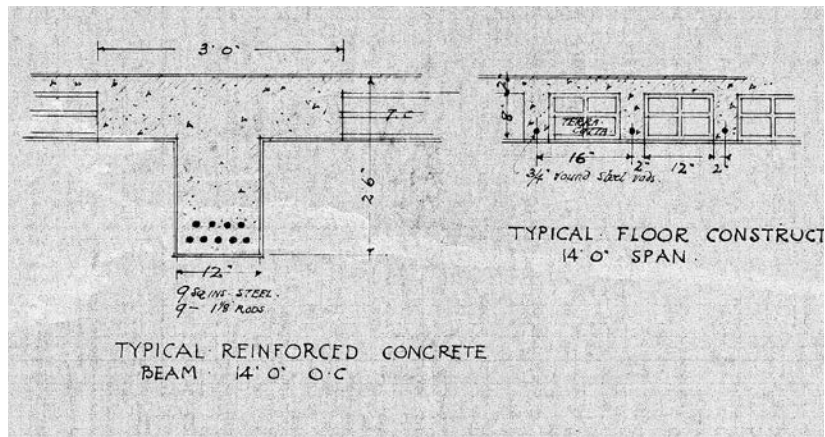

Figure 32. A 1917 section shows the floor structure of the Physics Building. Retrieved from Facilities Management Division Asset Record System, File P-2-T.

The building also still carries remnants of more common systems at the time. For example, fire hose carriers can still be found attached to some of the stand pipes (Figure 33). Also, as the building was constructed for use in scientific education and experimentation, many of the windows and transoms were equipped with hinged valance boxes (Figure 34). The valances were presumably provided to house dark blinds for controlling light levels in the labs. Some windows still have built-in chases and provisions for tying down the blinds. The hinged valances remain, but no blinds are known to still exist.

2.7 Use(s)

The Physics Building was originally used for classrooms, laboratories, equipment, recitation rooms and offices. It housed biology laboratories until a Biology Building could be constructed. As Figure 35 shows, the ground floor originally housed an apparatus room, an optics laboratory, offices and classrooms. When the building was first occupied in 1921, biology was allotted the two large ground floor labs, the large lab at the west end of the basement and a number of smaller rooms in the basement for offices. Physics occupied the rest of the building aside from a few other assorted uses.

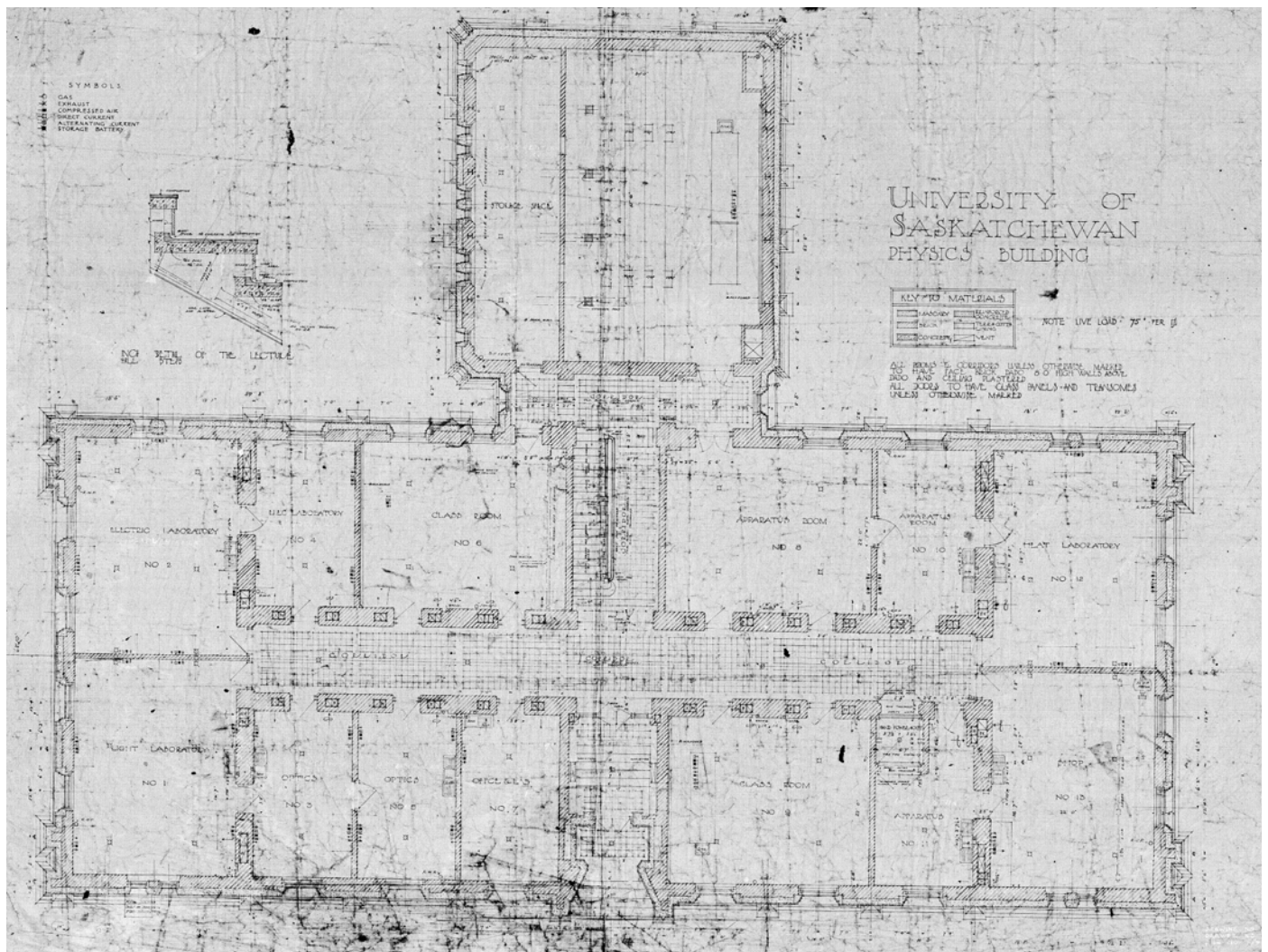

Figure 35. 1917 first floor plan for the Physics Building. Rooms were arranged with the assumption that professors would use minimal lab space in conjunction with classrooms and offices to carry out their research. Retrieved from Facilities Management Division Asset Record System, File P-9-T.



Figure 36. The ground floor has a seminar room where an apparatus room used to be.



Figure 37. East end of the ground floor corridor.

These other uses included a room for the Dominion Soil Analyst, the Shortt Library of Canadiana, a small medical library, and one room each for storage and a seismograph, all in the basement. The Physics Library was located on the second floor and in later years on the west end of the ground floor. It was incorporated into the Natural Science Library around 1986. The attic was used for varied purposes. Approximately four to five years after construction was completed the attic was divided into several spaces. These saw numerous occupancies: a lab for soil science, a painting studio for noted artist Augustus Kenderdine, storage for museum material from settlers originating in Central Europe, a room for binding books for the university library and the workspace of a taxidermist. Designated in the architect's drawings as museum space, the attic level is now home to graduate student offices, individual labs and equipment storage.

On the first floor, the rooms have in most cases retained their original size and configuration, but their uses have changed. This reflects the evolution of teaching and research practices over time. These rooms were designed on the historical assumption that experiments and research would be carried out by professors in small individual lab spaces. With changes in class size and experimentation methods these rooms were no longer sufficient for such uses and now house individual offices. Similarly, the room labelled 'Apparatus Room no. 8' in Figure 35 is now a seminar room, as shown in Figure 36.

The second floor has undergone much the same transformation as the first floor: from classroom space to office space. Once home to labs, offices, apparatus and recitation rooms it now houses the laboratories and offices of the Institute of Space and Atmospheric Studies. The rooms terminating either end of the first floor corridor are still existent and in use. Figure 38 shows the original uses of the second floor.

The main lecture hall pictured in Figure 39 is a character-defining element indicative of the building's original use. The room has stayed true to its original purpose and retains its commemorative integrity.

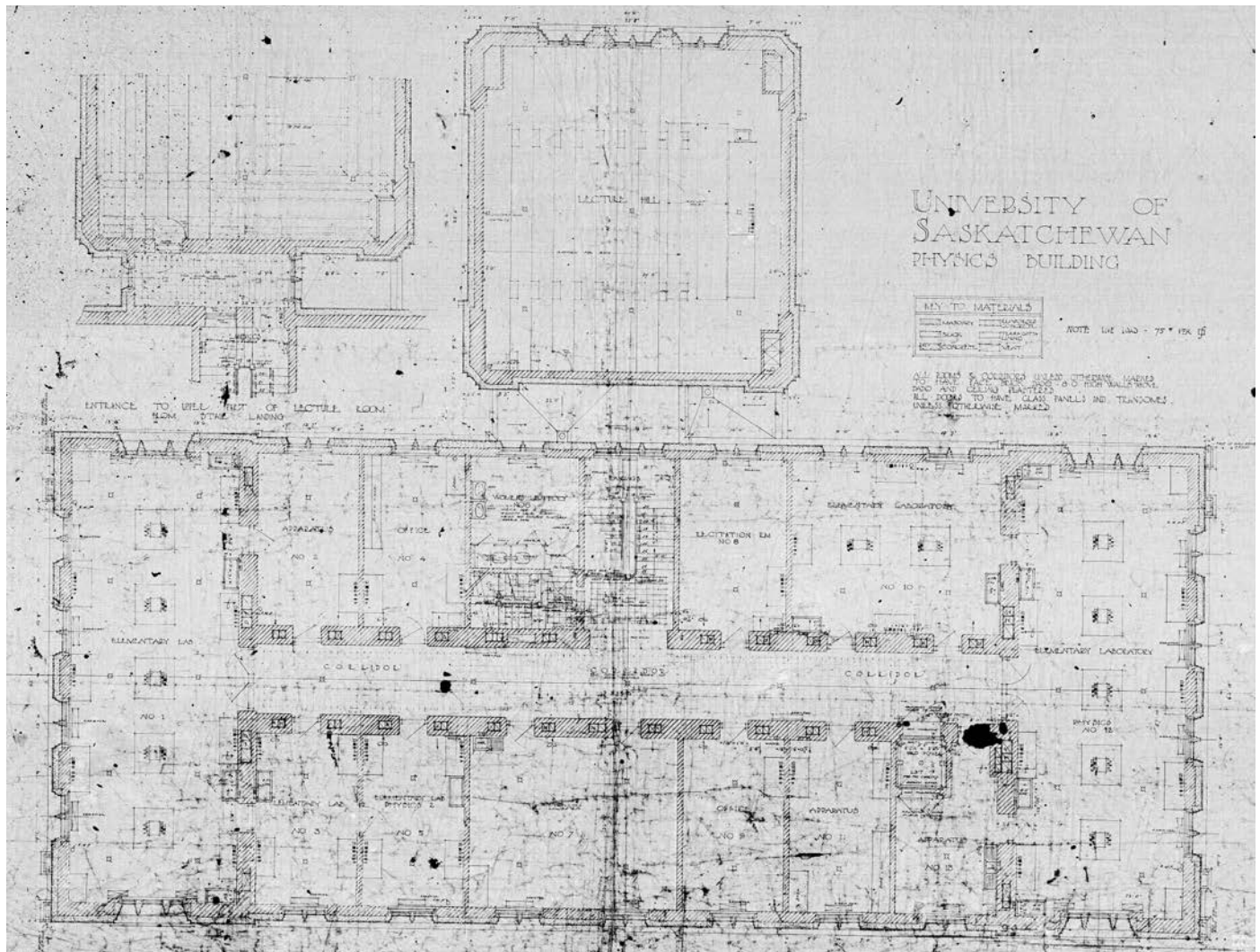

Figure 38. The 1917 second floor plan. Retrieved from Facilities Management Division Asset Record System, File P-8-T.

2.8 Cultural & Chronological Associations

In the circumstances of its delayed construction, the Physics Building may be associated with the First World War and the economic situation it created. The unfinished stone decoration at the main entry is also perhaps an indication of these economic difficulties (Figure 40).

Nobel prize winner Dr. Gerhard Herzberg is associated with the Physics Building. He was a member of the University of Saskatchewan Physics Department from 1935 to 1945. Herzberg was a physicist and physical chemist, who won the Nobel Prize for Chemistry in 1971, “for his contributions to the knowledge of electronic structure and geometry of molecules, particularly free radicals”.[2]. Herzberg’s work is commemorated in the Physics Addition as shown in Figure 41.



Figure 39. The University of Saskatchewan's first lecture hall.



Figure 40. Stone blocks over the entrance to the Physics Buildings were intended for future carved decoration, but were never completed.



Figure 41. A display in honor of Nobel Laureate Dr. Gerhard Herzberg.



Figure 42. The Physics Club in photographs dating from 1930 to 1967.

3. Associated Objects

The collection of Dr. Gerhard Herzberg memorabilia on display in the lobby of the Physics Building contributes to its character. Figure 42 shows another set of items that records the heritage of the building: a collection of photographs depicting the Physics Club through the years 1930 – 1967 is located on the ground floor, north of the staircase. They record a social aspect of campus life specifically linked to the Physics Building.

In October of 1983 a plaque and display case were dedicated inside the Physics building to commemorate the contribution of Dr. Balfour Currie and Dr. Frank Davies during the Second International Polar Year. Figure 43 shows the plaque being dedicated to the events happening in 1932-1933. The display case holds record books with observations as well as an auroral intensity recorder and original auroral photos.

Many objects of heritage value are stored in the building. These are shown in Figures 44 through 47. In the basement of the Physics Addition, old equipment and apparatus are stored. Objects of interest include: glass instruments hand blown by former Department Head Ertle Herrington (Figure 44), parts from the 1948 Betatron (Figure 45) and the first X-Ray unit in Western Canada (Figure 46).

Architects Brown and Vallance designed furnishings for the Physics Building that are shown in Figure 47.

4. Supporting Documents

Currie, B. (1976). *The Physics Department 1910-1976 University of Saskatchewan*. Saskatoon: University of Saskatchewan.

Rangacharyulu, C. Personal communication, June 10, 2011.

Facilities Management Division (2011). Asset Record System [Data File]. Retrieved from [\\usask\ fmddfs\files\iis\IIS_Public\ARS](http://usask.fmddfs/files/iis/IIS_Public/ARS)

Kerr, Don. (1989). Building the University of Saskatchewan 1907-1930. *Prairie Forum*, 5(2), 157-181.

Thomas, L.H. (1959). *The University of Saskatchewan 1909-1959*. Saskatoon: University of Saskatchewan.

University of Saskatchewan Archives. Buildings and Grounds Department 2015, 12, Presbyterian College, a) Brown D.R., c) Smith Bros, e) Miscellaneous.

University of Saskatchewan Archives. (Retrieved 2011). *Campus Buildings: Physics Building*. Retrieved from http://scaa.sk.ca/gallery/uofs_buildings/



Figure 43. 24 October 1983. Elva Currie (left) and Nell Davies unveil a plaque in the Physics Building to mark the contribution of their late husbands Drs. Balfour Currie and Frank Davies during the second International Polar Year in 1932-1933. Photo A-8619, retrieved from http://scaa.sk.ca/gallery/uofs_buildings/



Figure 44. Glass instruments hand blown by Ertle Harrington.

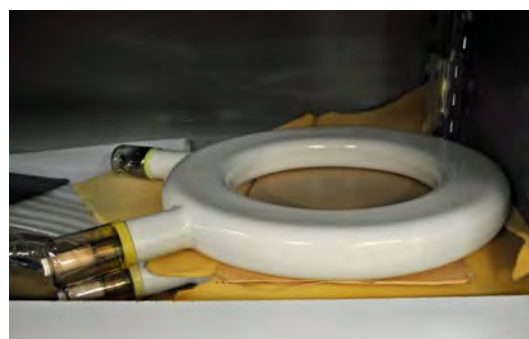

Figure 45. A part used in the betatron, ca. 1948.

5. Summary of Character - Defining Elements



Figure 46. Dr. Herbert Weaver's X-Ray Machine, the Ranney-Wimshurt-Holtz static machine. Dr. Weaver moved to Saskatoon in 1905 and the X-Ray machine arrived in 1906, making it Western Canada's first X-Ray unit.



Figure 47. Apparatus cases designed for the building by Brown and Vallance Architects.

Materials

- greystone walls
- Indiana limestone trim and decoration
- slate roofing and floors
- quarter sawn oak doors,

frames

- and window surrounds
- patterned glazing
- red clay tile floors
- grey granite base course
- brick interior walls,

wainscoting

- and arches
- plaster walls and ceilings
- steel framed windows
- brass door and window hardware and grates
- cast iron and steel tablet arm chairs
- cast iron and steel staircase with slate treads
- cast iron radiators
- slate chalkboard

Form

- scale (3 storey height)

Style

- arches and gothic arches (doors, windows, entries, transoms)
- keystones
- stone piers
- string courses
- absence of stone ornament
- stone spandrel panels
- horseshoe arches

Location	<ul style="list-style-type: none"> ▪ vaulted plaster ceilings ▪ on secondary axis of the Bowl ▪ enclosing northern edge of the Bowl ▪ terminates axis of Voyageur Place
Spatial Configuration	<ul style="list-style-type: none"> ▪ double loaded corridors ▪ small, individual 'lab spaces' ▪ double height lecture theatre ▪ high ceilings
Systems	<ul style="list-style-type: none"> ▪ concrete floors with embedded clay tile ▪ remaining components of historical power distribution system ▪ fire hose carriers ▪ exposed truss in attic ▪ hinged blind boxes
Use(s)	<ul style="list-style-type: none"> ▪ continuous use for physics education and research (classes, labs, apparatus storage, offices, recitation rooms, workshops) ▪ studio of Augustus Kenderdine
Cultural & Chronological Associations	<ul style="list-style-type: none"> ▪ first lecture theatre (housed classes from every department) ▪ unfinished stone ornamentation ▪ Nobel Prize winner Dr. Gerhard Herzberg



013

Thorvaldson Building



013

Thorvaldson Building

Alternate Names

Chemistry Building

Architects

David R. Brown, Brown and Vallance Architects, Montreal

David R. Brown Architect, Montreal

Builders

Bennett and White, Shannon Brothers

Construction Dates

1921-1924, additions in 1966, 1988 and 2003

Recognition

University of Saskatchewan 'A' Listed

1. Statement of Significance

Originally named the Chemistry Building, the Thorvaldson Building was designed by Architect David R. Brown of Montreal. Hugh Vallance, Brown's former partner, left the firm in March of 1923 to form his own practice. Although preliminary drawings for the building were completed in 1913, the structure was not built until 1924 due to the disruption of the First World War, followed by economic constraints. The building as realized reflects the affluence of the roaring twenties in its ambitious scale, rich materials and detailed execution. In these respects, it also represents the apex of the Collegiate Gothic phase of architecture at the University of Saskatchewan. The building is of significant heritage value by virtue of its age, historical importance and the high quality of its design and craftsmanship. In 1966, the building was expanded and renamed in honour of Thorbergur Thorvaldson, whose research into the chemical and material properties of concrete resulted in important advancements to this construction material. (Additions carried out to the building in 1966, 1988 and 2003 are beyond the scope of this report).



Figure 1. Greystone walls, Indiana limestone trim and window surrounds, painted steel framed windows and granite base course.

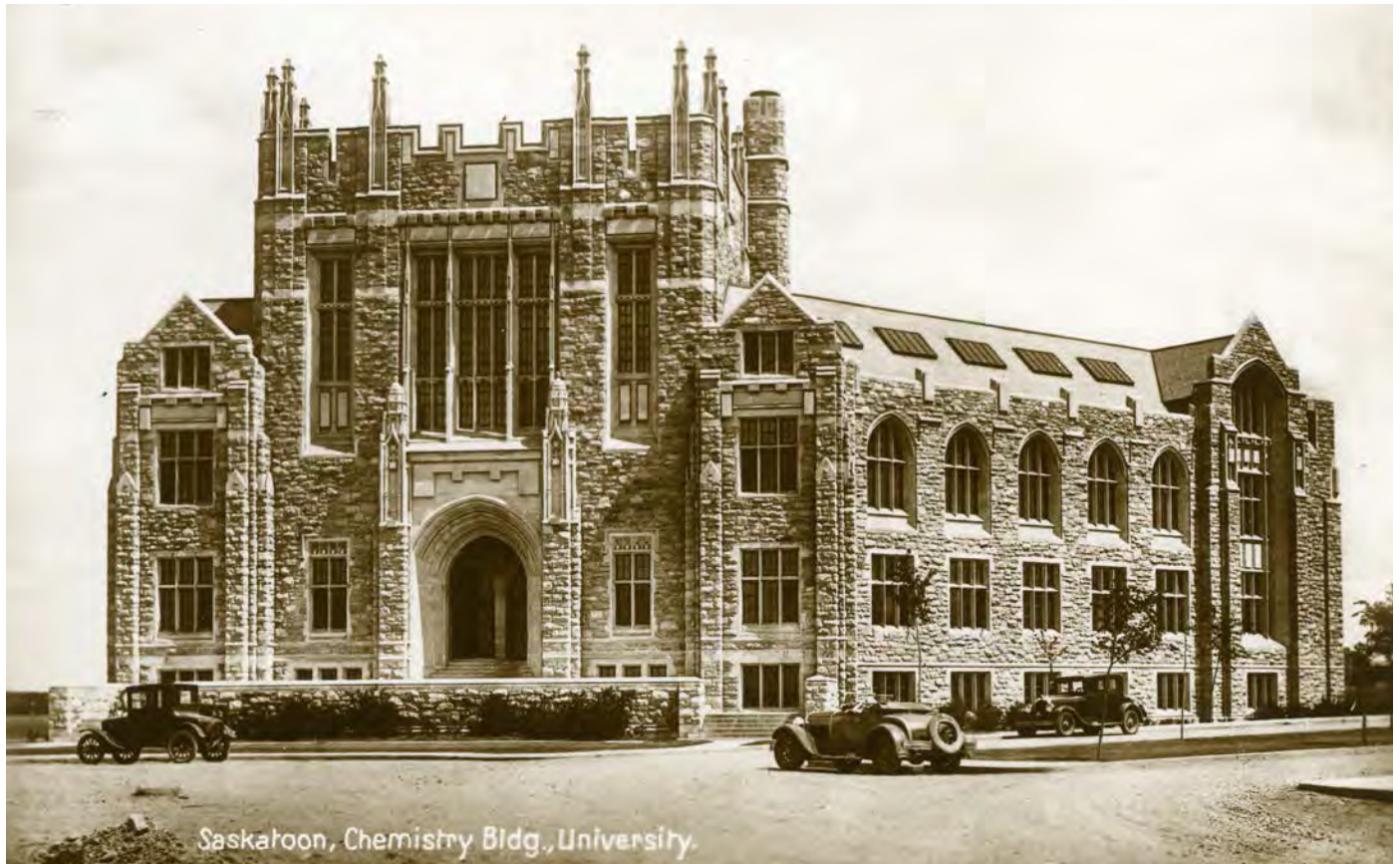

Figure 2. The Thorvaldson Building, 1924. Photo A-3923, retrieved from http://scaa.usask.ca/gallery/uofs_buildings/

Note: The Thorvaldson Building is configured with floors numbered Basement, Ground Floor, Second Floor, etc... This report follows the same convention.

2. Character - Defining Elements

2.1 Materials

'Greystone', in a buff color with scatterings of pink and purple, is the principal exterior material of the Thorvaldson Building. This material is significant both for its local origin and because it characterizes the early architecture of the University of Saskatchewan campus. A fine-grained grey granite forms the building's base, as well as the stairs leading to its grand main entrance. Doors and windows are trimmed in Indiana limestone, which is also used for various other decorative stone elements. All of the stone materials have heritage value as elements defining the character of the building. The stone of the Thorvaldson Building generally remains in a state of excellent commemorative integrity. (For further information on building stones used at the U of S, refer to ['Appendix: Stone'](#)).



Figure 3. Slate tile roofing, lead covered louvres on exterior venting.



Figure 4. Replacement windows in the northern annex.



Figure 5. Oak door frame and transom with carved gothic motifs.



Figure 6. Brick wainscoting, quarter sawn oak door and brass door hardware.



Figure 7. Red terracotta tile, slate stair treads, iron balustrade and bronze banister.

Pitched roofs were originally clad in slate, and most remain so, although it is not known how much original material remains. Roof flashings and ridge caps were formed from copper. Some of these elements have been replaced with prefinished steel, but much of the copper remains in a good state of commemorative integrity (Figure 3). The east wing of the building originally featured a saw-tooth roof with skylights, but this feature has been removed and replaced with a conventional flat roof. Ventilation louvers on the back side of the tower were clad in lead, which remains in place (Figure 3).

The windows of the building are generally single-glazed steel-framed casements of which there is both an exterior and an interior set. These remain in excellent condition with the exception of the east wing. There, the original double-height steel framed windows have been replaced with aluminum framed windows (Figure 4).

The main entrance of the Thorvaldson building features an elaborate portico, with a carved limestone archway leading to a vestibule formed by two sets of oak doors. The exterior doors are replicas of the original oak doors, made in 2011, and mounted in the original oak frame. The interior doors are set into an intricate oak frame and transom, carved with various gothic motifs. This feature is a striking piece of artistry and is in very good condition (Figure 5).

The finish materials of the interior of the building exist in varied states of commemorative integrity. Many of the original oak doors remain, including their brass hardware, and are generally in good condition (Figure 6). Although some have been removed or replaced. Public corridors have red clay terracotta floor tile which is generally in good condition. In the basement some replacements have occurred. In the public corridors and many other rooms, walls are of painted plaster, with brick wainscoting (Figure 6). These character-defining materials are generally in excellent commemorative condition where they have survived.



Figure 8. Remaining wood panelling over replaced sink.

The main stairs of the Thorvaldson Building are a grand feature dominating the entrance hall. The stairs are formed of slate treads, with painted steel stringers, a cast and wrought iron balustrade and a bronze handrail (Figure 7). In 2012, the slate treads and landings on the staircase were replaced with new slate matching the original material.

In the laboratories, classrooms and offices, some material integrity has been lost. Originally the building featured birch flooring in its laboratories and classrooms, but none remains. The laboratories featured stone sinks made of New York granite with porcelain covers. These have been replaced with stainless steel sinks such as the one shown in Figure 8. Blackboards were specified for all labs and classrooms; three chalkboards of slate and oak remain and are in good condition. The largest of these boards is the sliding chalkboard which is still used in the auditorium today. The oak chart frames in the auditorium space have also been maintained. The brick wainscoting, steel and brass window hardware and wooden trim of the windows has been maintained in the classrooms, labs and many offices (Figure 9).

The auditorium or ‘Airplane Room’ is well-known at the university both for its striking form and for its historical integrity. Its materials are largely unchanged. Painted plaster and brick walls are well-maintained and original. The steel and wood tablet arm chairs are original but are in poor commemorative condition. The tablets record decades of student graffiti with dates as far back as 1933. The concrete of the tiered floor has been covered by vinyl composition tile (VCT), but the risers have their original concrete finish. The brass ventilation grilles have been well maintained (Figure 11). The domed ceiling of the Airplane Room has long been covered in a spray-applied acoustical material. An alumnus who attended class in the space from 1947-1950 recalls that the ceiling was, “like the rest of the ceilings in the building,” and that the asbestos finish on the dome came later (Tom Jasienuk, personal communication, August 17, 2012). With this information it can be assumed that the dome was finished in plaster. Ceramic tiles are still visible in the flat ceiling surrounding the dome. (Structure discussed in section 2.5 Systems). The oak-framed windows remain in excellent commemorative condition. The bottom row of windows have been rendered opaque with the addition of dark steel panels into the window frame as shown in Figure 11. Underneath the large windows is an oak cupboard with brass screens which houses cast-iron radiators. The commemorative integrity of this cabinet is intact (Figure 12).



Figure 9. Steel window frames with oak surrounds and brass window hardware.

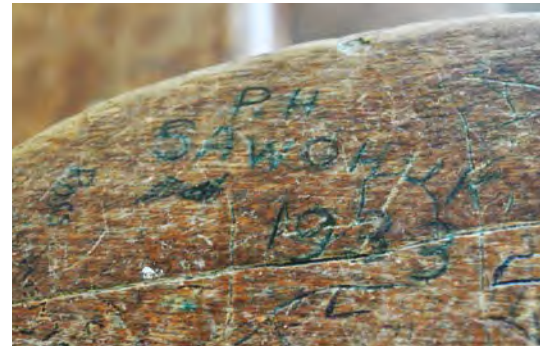

Figure 10. Graffiti on a lecture theatre tablet dated 1933.

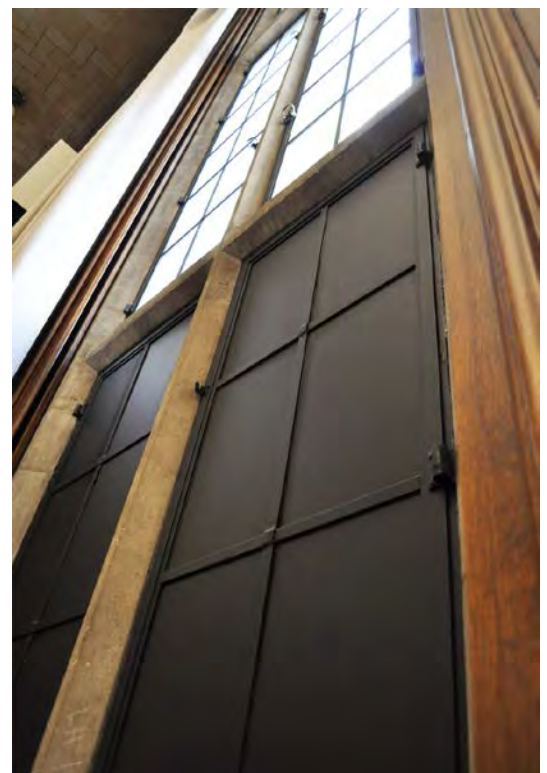

Figure 11. Original windows with opaque steel panels.



Figure 12. Painted cast iron radiators in original oak cabinet with brass screen.



Figure 13. The Thorvaldson Building, ca. 1930. Photo A-10983, retrieved from <http://sain.scaa.sk.ca/items/index.php/chemistry-building-5;rad>



Figure 14. Chapel at King's College, Cambridge. Retrieved from http://en.wikipedia.org/wiki/File:Kings_College_Chapel_Cambridge.JPG

2.2 Form & Style

The Thorvaldson Building, in its form and detail, illustrates the European and ecclesiastical roots of the Collegiate Gothic architectural style perhaps better than any other building at the University of Saskatchewan. Compare, for example, the Thorvaldson Building (Figure 13) to the chapel of King's College Cambridge (Figure 14). The imposing scale of the Thorvaldson Building, its verticality, the character of its grand entrance, and its stylistic references to architectural elements such as flying buttresses, spires, and church portals make clear reference to this and other precedents in European Christian architecture.

The Thorvaldson Building was never completed as planned; it was originally designed to have a north wing that would have made it symmetrical. In the original design, intended to be realized in two stages, the large tower element containing the main entrance and the auditorium was a central volume connecting two lower classroom and laboratory wings. Figure 15 shows the building as it stood at the completion of its first phase. The form of the Thorvaldson Building maintains its commemorative integrity, since little of the original building has been removed; however, over the years it has been expanded significantly.



Figure 15. 1924, the original form of the Chemistry Building. Photo A-249 retrieved from <http://sain.scaa.sk.ca/items/index.php/university-of-saskatchewan-archives;isdiah>



Figure 16. References to flying buttresses in the stonework of the Thorvaldson Building.

The cut and carved limestone reliefs and sculptures on the Chemistry Building differ from those of its predecessors in that they are generally not figural representations, but instead represent purely architectural motifs. For example, there are examples of gothic arches, stylized flying buttresses, battlements, finials and trefoil motifs, but no human figures, gargoyles or grotesques. A unique character-defining element of this building, visible in Figure 16, is its tracery on the large panel of glazing on the front elevation. This carved stone element is a subtle representation of a series of flying buttresses, compressed into the thickness of the window opening. The most exuberant examples of carved stone decoration are found above and surrounding the principal entrance. A ribbed arch forms the entrance, in the manner of a cathedral portal. A brick vault, laid up in a herringbone pattern, separates the portal from the doors (Figure 17). Collegiate Gothic decoration is to be found on virtually all of the building's exterior surfaces. Greystone quoining defines the corners of the building and a crenellated parapet forms its roofline. The uppermost windows are all shaped as gothic arches, as shown in Figure 18. These windows have been maintained in a good state of commemorative integrity. The central wing of the building features a row of double-height arched windows (Figure 4), which are also character-defining elements.

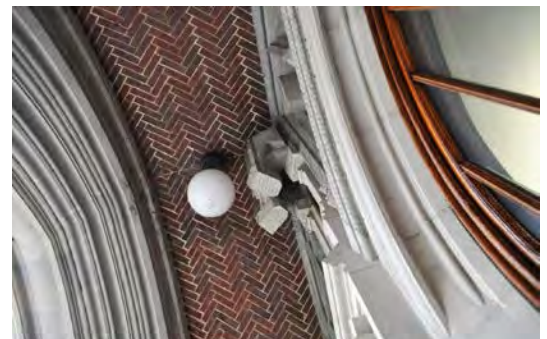

Figure 17. Tiled vault with gothic arches on either side.



Figure 18. Gothic arch windows below a crenellated parapet.



Figure 19. Balustrade detail.

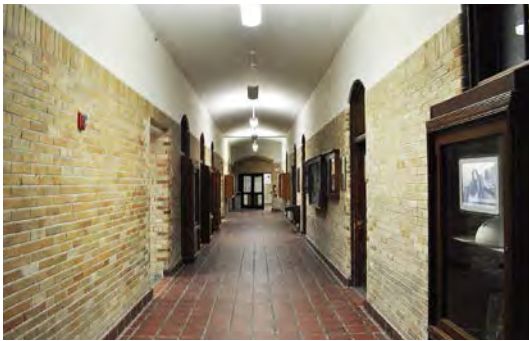

Figure 20. Interior stylistic elements include arched transoms and vaulted ceilings.



Figure 21. Transoms in the basement have been compromised by a dropped ceiling.

The interior of the building also contains many character-defining stylistic elements. The main entrance has an intricate carved wooden screen surrounding the doors (Figure 5). In the foyer, the ceiling is in the form of a series of intersecting plaster vaults (Figure 18). This staircase, in slate, cast and wrought iron, is a significant character-defining element. (Refer to Section 2.2) The balustrades of the staircase are supported by ornate wrought iron brackets shown in Figure 19.

Figure 20 shows the brick wainscoting lining corridors and the arched transoms above doorways on the 1st and 2nd floors. (The transoms of the third floor are not arched). All of the corridor ceilings, with the exception of those in the basement, are vaulted. Most of the arched transoms exist in a good state of commemorative integrity with the exception of the basement level, where a dropped ceiling now obscures these character-defining elements, as shown in Figure 21. In some places transoms have also been replaced with an opaque material.



Figure 18. Plaster vault and dome, terracotta tile floor.

The auditorium of the Thorvaldson Building, also known as the Airplane Room, exhibits many character-defining elements of style. The most obvious element is the 68 foot dome which crowns the room. The dome remains in good commemorative condition. Its form has been maintained, and although the ceiling has been covered with a fibrous fireproofing material, that material has itself acquired its own historical significance, as discussed in Section 2.8. The location and volume of the Airplane Room are registered on the front elevation of the building, by the large panel of windows above the main entrance. These soaring windows and of the scale of the space itself contribute greatly to the grand style of the building, reinforcing the imposing impression of the stone exterior (Figure 22).



Figure 22. The dome of the 'Airplane Room.'

2.3 Location

The Thorvaldson Building does not appear on the original Brown and Vallance plan of 1909 (Figure 23), but was added at a later date. It first appears in its final configuration on a 1924 revision to the master plan, drawn while the building was under construction. David Brown included this revised plan in an article for the *Journal of the Royal Architectural Institute of Canada*, describing the architecture of the campus. Figure 24 shows the 1924 plan with the Thorvaldson Building included. The orientation of the building distinguished it from its predecessors; the Thorvaldson Building did not face inward, toward the 'Bowl,' but outward, towards the river and the growing city of Saskatoon.

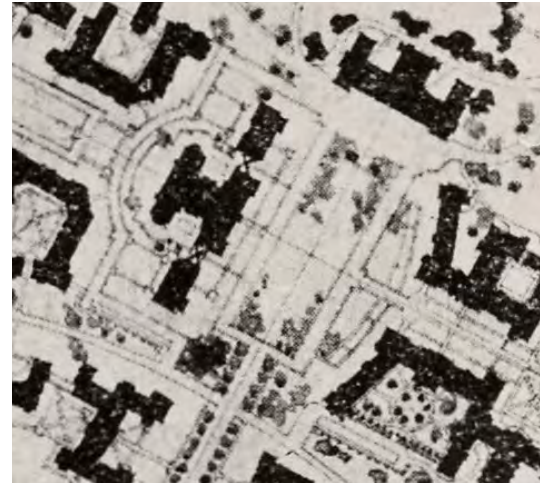

Figure 23. The Thorvaldson Building is not shown on the 1909 Campus Plan. The plan is oriented with north to the left.



Figure 24. The location and orientation of the Thorvaldson Building is indicated in green on a 1924 version of the Campus Plan. The plan is oriented with north to the left. Retrieved from Avery, C. (2007). *Oasis for Learning: Landscaping at the University of Saskatchewan*.

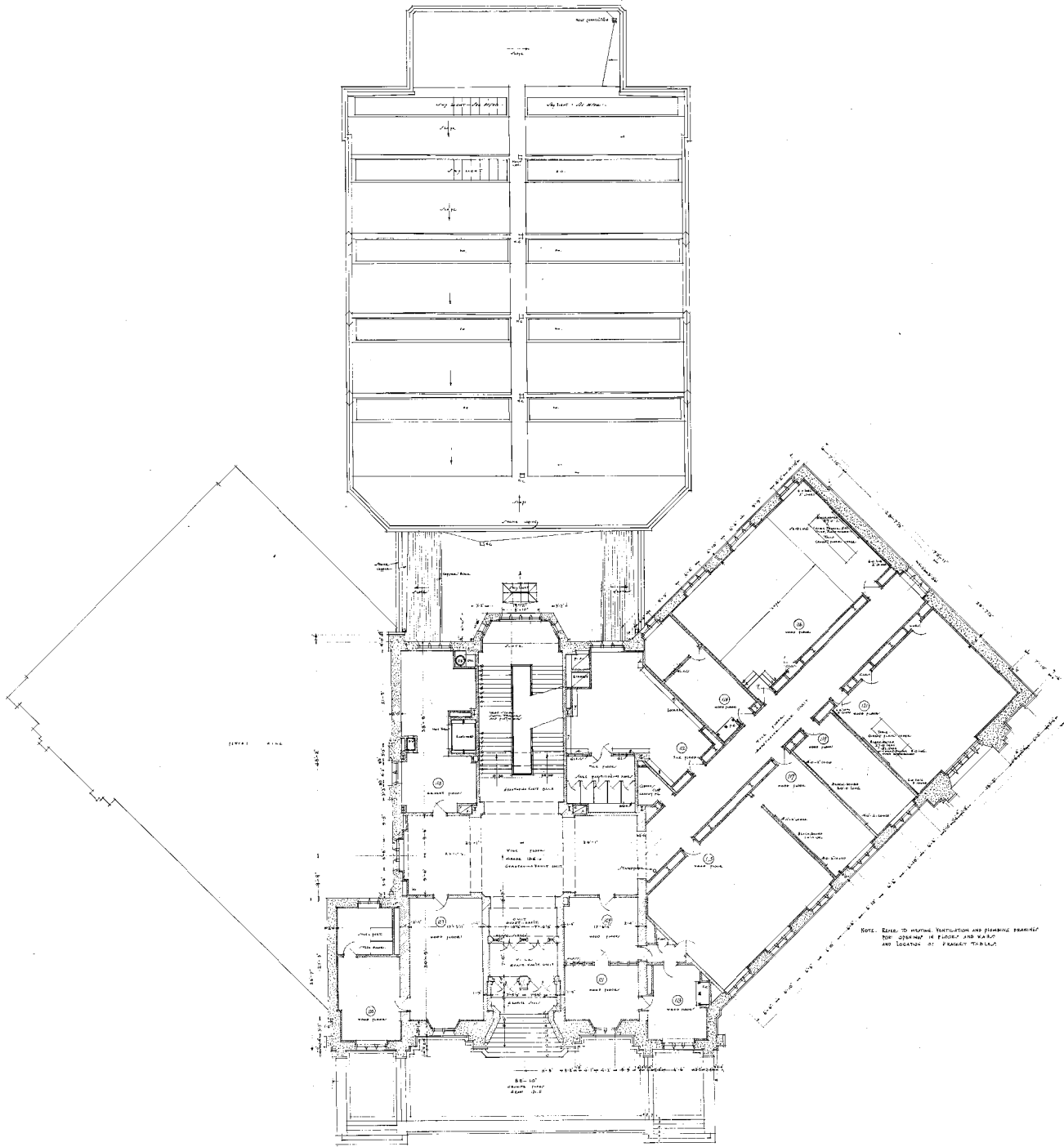
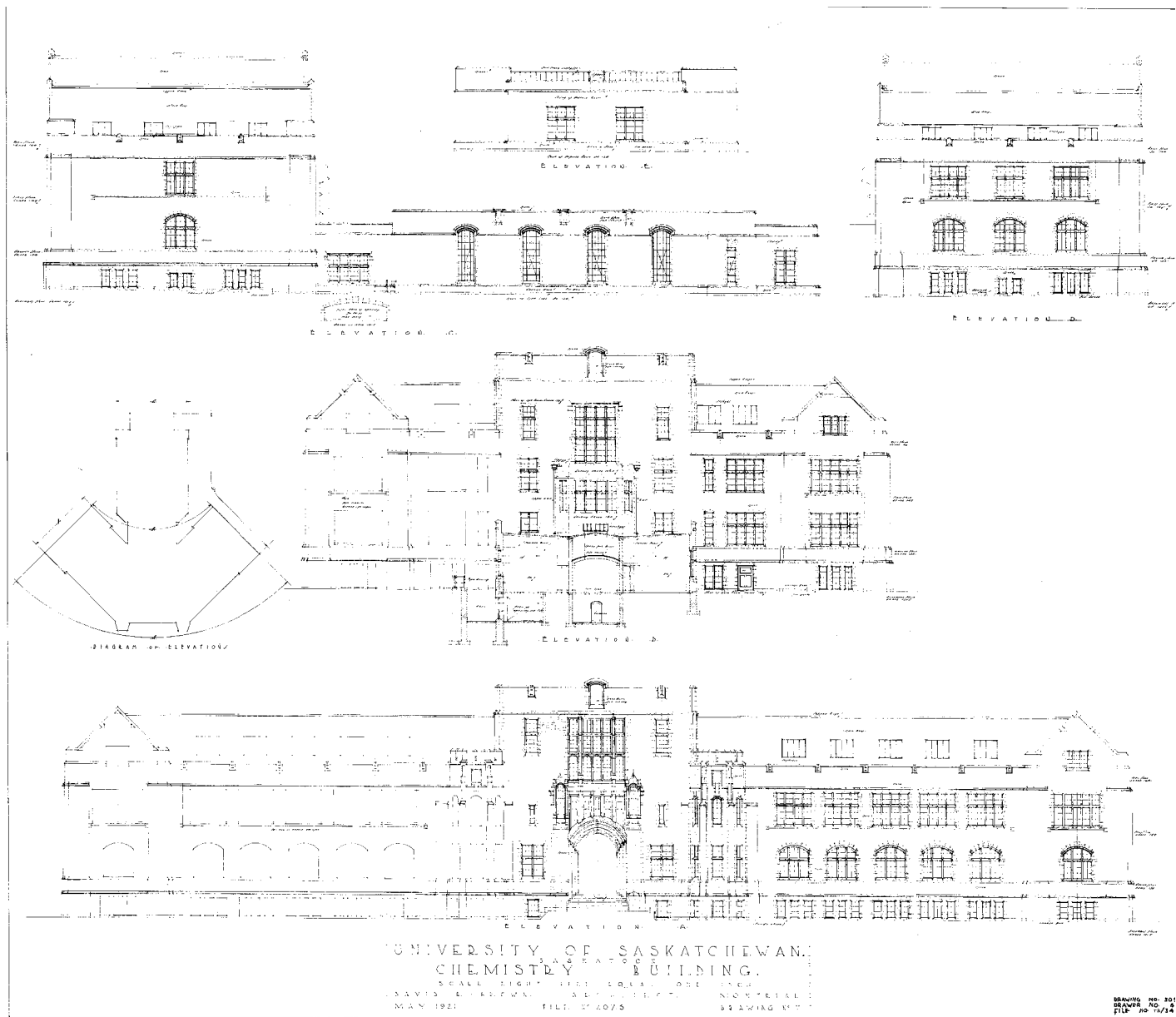

Figure 25. Original ground floor plan. North is oriented to the left. Retrieved from Facilities Management Division Asset Record System, File TB-10-T.

2.4 Spatial Configuration

The Thorvaldson Building as originally conceived has an unusual floor plan, shaped in the form of an arrow, with three wings intersecting at 45 degree angles, at the main entrance. This plan was never fully realized, and is missing its north wing, but the shape and configuration of the other two original wings have been maintained to a good degree of commemorative integrity, despite later additions. Figure 25 illustrates the original ground floor plan, with the missing north wing shown in outline. Figures 26 and 27 illustrate an early version of the building that was eventually discarded in favour of the current design.



The laboratories and classrooms of the Thorvaldson Building were configured along double-loaded corridors, with the exception of the large auditorium and the central laboratory wing. The corridors remain very much intact, but the rooms arrayed along the corridors have been changed in many instances. In the late 1940's, there were about 5,000 students attending classes on campus. The population was large relative to the space available on campus and so labs in the Thorvaldson building were converted into lecture rooms to alleviate the situation. The problem was so severe that the university brought in old aircraft annexes from the airport to serve as laboratory space (Tom Jasienuk, personal communication, August 17, 2012). Aerial photos of the campus show that the annexes appeared in 1946, were reconfigured in 1965 and had been removed by the spring of 1977 (University of Saskatchewan Archives, Photo B-545). The labs of the basement floor were enlarged by the removal of partition walls.

Figure 26. Early elevations show a window configuration different from the one existing today. The entrance in this version is also more simple. Retrieved from Facilities Management Division Asset Record System, File TB-34-T.

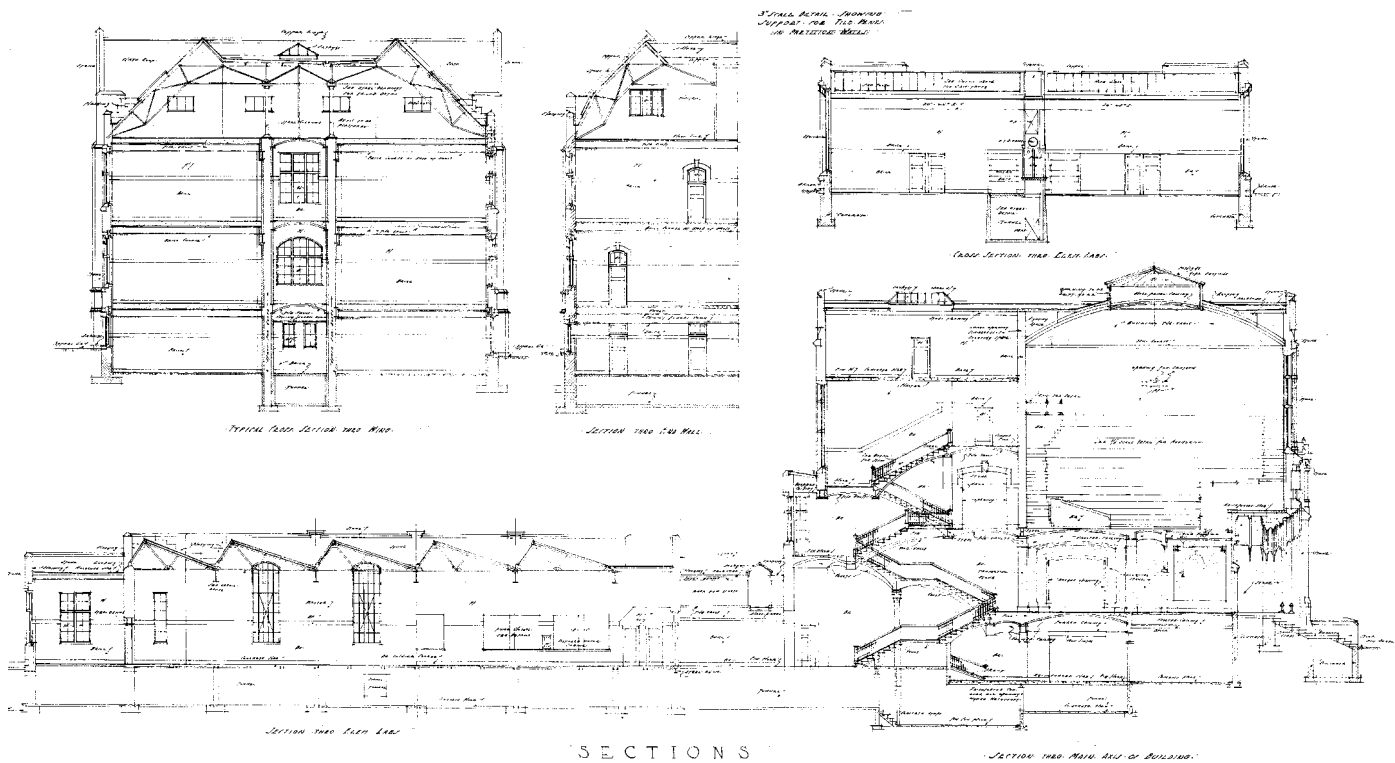

Figure 27. Early sections depict the airplane room with a skylight in the guastivino dome. Retrieved from Facilities Management Division Asset Record System, File TB-2-T.



Figure 28. Several doors have been replaced by display cases.

The double loaded configuration of the corridors remains and is a character-defining element. The rooms arranged along these corridors have seen much renovation. The configuration of many rooms has changed to accommodate evolving spatial requirements. Some rooms have been subdivided by the addition of partition walls and others have been combined to create larger spaces through the removal of walls. In order to accommodate the new spatial configurations, some doors in the corridors have been removed and replaced with display cases as shown in Figure 28.

The spatial configuration of the large auditorium, or Airplane Room, has not changed and has a high degree of commemorative integrity. Its volume is based on an almost cubic proportion, bisected by the tiered floor of the seating, such that its height and width are equal, although it is slightly longer than it is wide. The room is crowned with a shallow dome.

The public spaces of the Thorvaldson Building, such as the corridors and the grand staircase, have maintained their commemorative integrity. The arrangement of these spaces has not changed, except where original corridors connect to newer additions. An overhead walkway from the Geology Building now enters the building immediately east of the grand staircase. Also, a large addition was appended to the west side of the building in 1966. The east wing has also been extended slightly, with the addition of a fire stair.

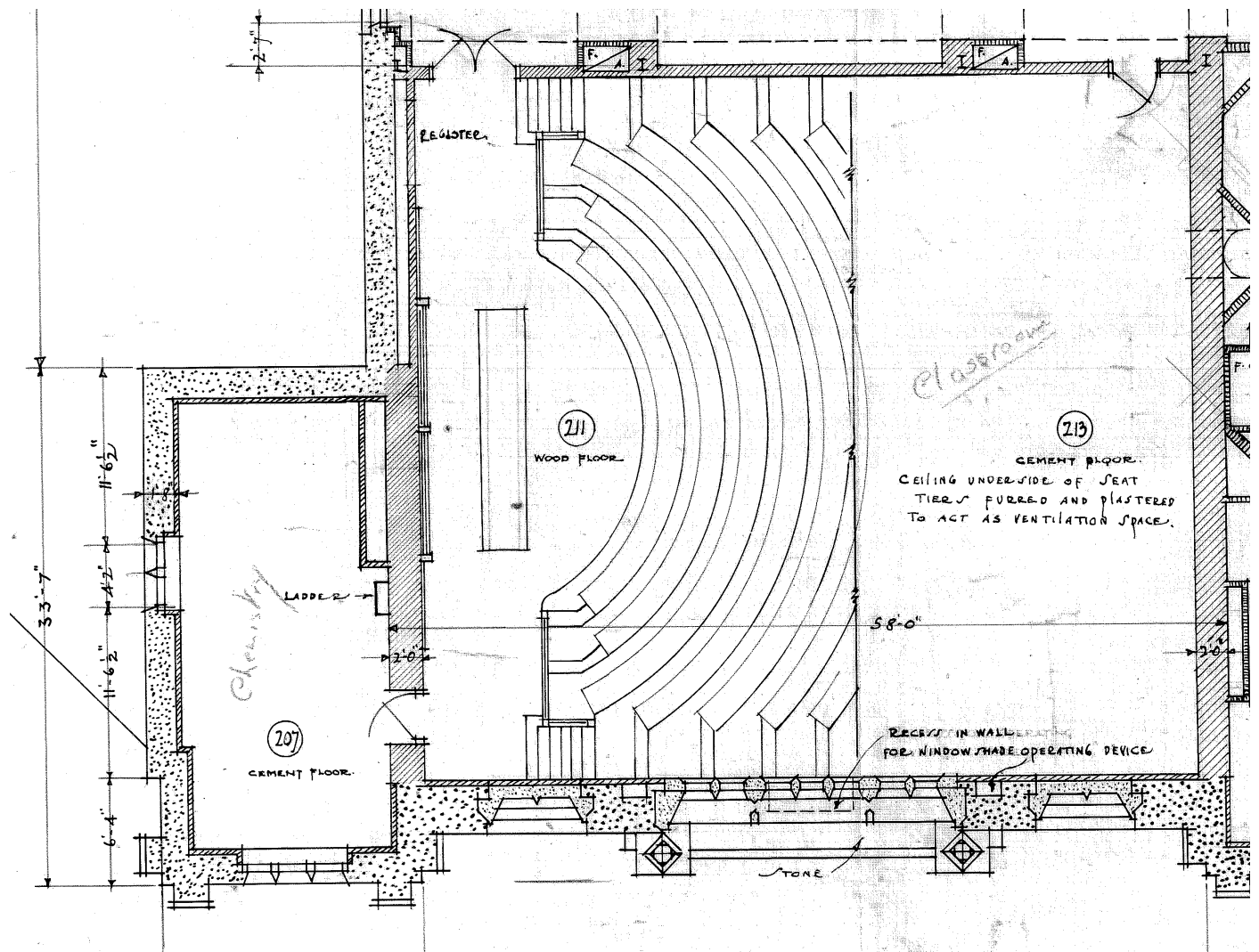

Figure 29. Plan of original configuration of the auditorium. The door to the anteroom exists but is no longer functional. Retrieved from Facilities Management Division Asset Record System, File TB-11-T.

2.5 Systems

The dome of the Airplane Room is a feature of particular heritage significance. This dome is an example of the 'Guastavino Tile Vault System', a system for the construction of thin-shelled structural vaults and domes patented in 1885 by a Spanish-American architect and builder named Rafael Guastavino (1842–1908). The Guastavino system was briefly popular in buildings of the Beaux-Arts style at the turn of the 20th century. It was used in prominent buildings such as New York's Grand Central Station and Toronto's Union Station. The system used standardized terracotta tiles and layers of mortar, laid up in an interlocking herringbone pattern, to form a thin, self-supporting shell about 4 tiles deep. The tiles were laid flat and parallel to the arc of the vault, rather than perpendicular to the curve, as in the Roman fashion. The terracotta tiles were about 10 mm thick, and approximately 150 mm by 300 mm in dimension.



Figure 30. The Thorvaldson Building with the 1966 addition. Photo A-63255 retrieved from <http://sain.scaa.sk.ca/items/index.php/university-of-saskatchewan-archives;jsdiah>

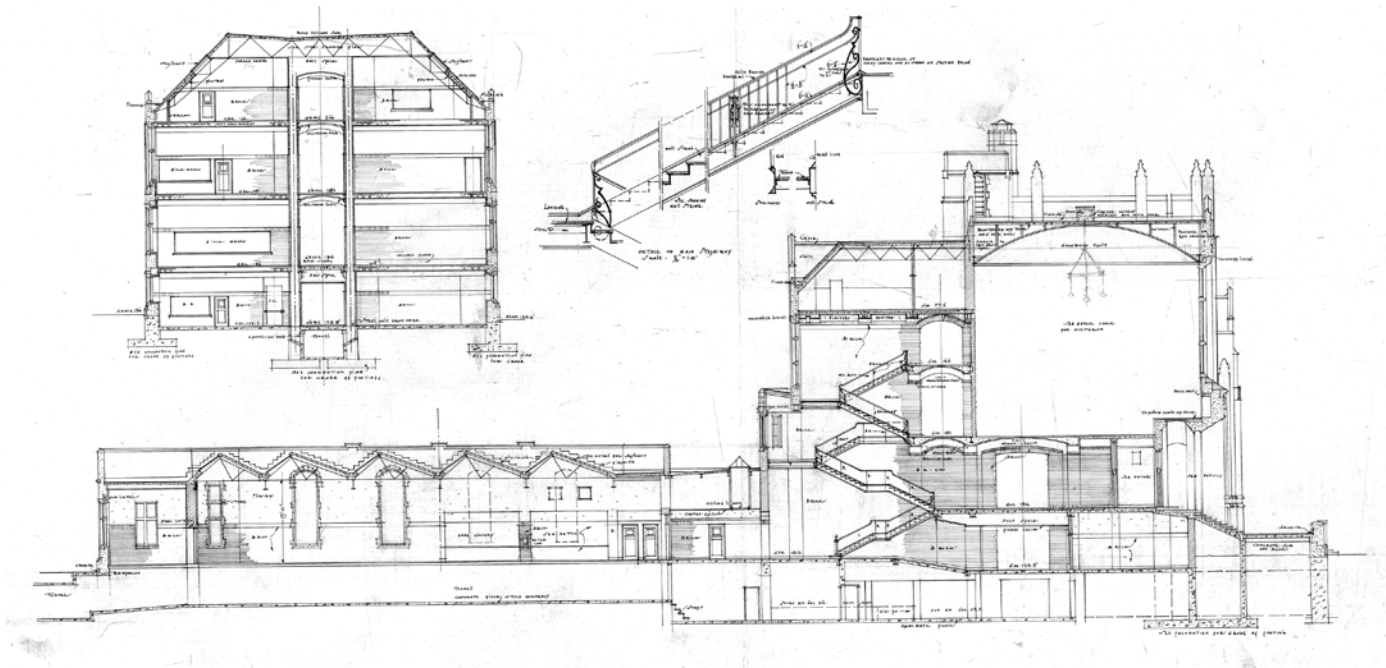

Figure 31. Sections through the building show the structure of the dome and the steel trusses used to support the roof. Retrieved from Facilities Management Division Asset Record System, File TB-15-T.

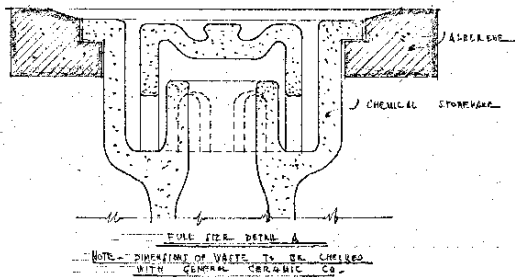

Figure 32. Detail of chemical waste trap showing use of ceramic plumbing and alberene stone sink. Retrieved from Facilities Management Division Asset Record System, File TB-77-T.



Figure 33. Stone sink located in the sub-basement of the Thorvaldson Building.

The dome of the Thorvaldson Building auditorium constitutes a character-defining element, both as a structural system particular to the historical period of its construction and as a prominent aesthetic feature. As a structural system, the Guastavino tile dome has commemorative integrity, although its original appearance has been compromised. The dome would likely have been finished originally in painted plaster, but is now covered with a spray-on acoustic material. This was done in order to mitigate an echo problem associated with the domed shape, but interestingly, has also contributed to the heritage value of the room in other ways, discussed in Section 2.7.

From the original architectural drawings, the structure of the building appears to be a hybrid system, with a structural steel frame encased in cast-in-place concrete on the interior, and exterior walls consisting of cast-in-place concrete, brick and stone. The roof structures typically consist of concrete slabs supported on steel trusses, with the notable exception of the Guastavino dome. Although a dropped ceiling has been installed in the attic, some of the steel structure at this level is visible. Floors are typically cast-in-place concrete, with embedded hollow clay tile, a system seen also in the [Physics Building](#). The drawings indicate cast-in-place concrete foundation walls and footings.

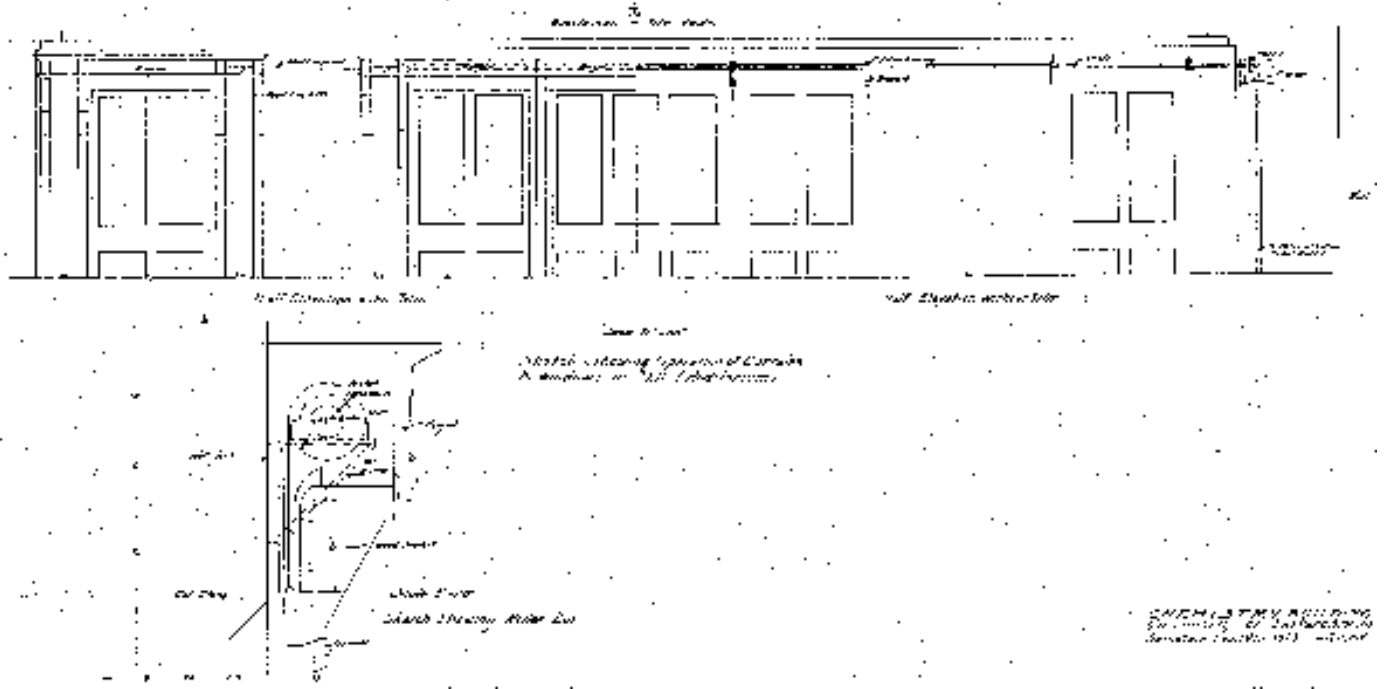

The ventilation and plumbing systems in the Thorvaldson Building were considered state-of-the-art at the time of their construction. All fume hoods and vents were covered in an acid proof lining. Labs came equipped with distilled water cabinets made of porcelain and stone. Parts of these oak cabinets still exist, and are visible above their newer counterparts (Figure 8). Labs also were built with sand baths which would put out a fire with a shower of sand if needed. As an additional precaution, water baths were also installed. (The sand baths no longer exist and the water baths have now been replaced). The plumbing at the work benches was specified in the best chemically-resistant materials available at the time: soapstone sinks and ceramic pipes. Figure 32 illustrates the details of the stone sink and ceramic waste trap. This system has been replaced, but some of the original stone sinks has been saved and at the time of this report are located in the sub-basement (Figure 32). The original plans indicated the provision of speaking tubes near the elevator, but these also no longer exist. The labs were equipped with two plumbing lines; one provided water and the other provided a solution of 80% alcohol intended for sterilizing equipment. Former student Tom Jasienuk recalls, “they rarely used the alcohol to sterilize and would fill bottles with it and go party. They’d have to cut it with 7-Up, juice or water because it was too strong...they frequented that tap a lot” (personal communication, August 17, 2012). With the removal of the lab spaces to the annexes the alcohol line was disconnected.

The original heating system of cast iron radiators, shown in Figure 12, was common at this time. The building’s radiators remain in good condition and are still in service.

Figure 34. Detail of window covering mechanism in the 'Airplane Room.' Retrieved from Facilities Management Division Asset Record System, File TB-81-T.



Figure 35. Dark blinds still exist over some of the transoms.



Figure 36. Dr. K. J. McCallum lectures in the 'Airplane Room'. Date unknown; possibly 1959. Photo A-1650 retrieved from <http://sain.scaa.sk.ca/items/index.php/university-of-saskatchewan-archives;jsdiah>



Figure 37. A 1924 architect's sketch of the Thorvaldson Building. Photo A-5955, retrieved from <http://sain.scaa.sk.ca/items/index.php/?search=query=a-5955>

A unique apparatus was designed to operate the curtains and blinds of the high windows in the auditorium. The oak window surrounds were built to contain a system of gears that would allow for the curtain to be drawn from below the window. This system is no longer used, but the apparatus may still be in existence within the oak window frame (Figure 34).

Blinds were also installed in the auditorium, as well as over the door transoms in the basement laboratories. When not in use, the blinds retracted into recessed pockets above the window frames. It is unknown whether they still exist within the frame of the auditorium windows, but the blinds do still exist in some cases in the laboratories (Figure 35). 'Pantasote' was the material used for these blinds. Pantasote was a leather substitute common in the early twentieth century, created by gluing together two layers of fabric with Pantasote gum. The surviving blinds are character-defining elements.

2.6 Use(s)

The Thorvaldson building was originally referred to as the Chemistry Building, replacing the makeshift labs in the basement of the [MacKinnon Building](#) that had up until that time housed the Chemistry Department. The building was also originally home to the Colleges of Home Economics and Pharmacy. The Thorvaldson Building now houses labs for chemistry and is also home to the Computer Science Department. The original plans for the building show that it was composed of several small labs, classrooms, store rooms and an auditorium. Labs, classrooms and the auditorium are all therefore character-defining elements. The ground floor was originally home to several labs, but is now almost exclusively offices. The use of the basement for laboratories is historically consistent. The second and third floors are home to computer labs, offices and seminar rooms. The use of the auditorium has never changed and its commemorative integrity as a lecture theatre remains intact.

When a member of the University of Saskatchewan community dies, the flag on the Thorvaldson building is flown at half mast.

2.7 Cultural & Chronological Associations

The Thorvaldson Building was the most elaborate of the early campus buildings, reflecting the confidence of the early 1920's (Figure 37). "It faced not inward toward The Bowl and the original buildings, but outward to what was expected to be an expanding future", (University of Saskatchewan Archives, retrieved 2012, *Campus Buildings: Thorvaldson Building*). However, the fact the north wing was never realized perhaps reflects the effect of the stock market crash of 1929, and the subsequent Great Depression.

The lecture hall, or Airplane Room, in the Thorvaldson Building is a particularly rich focus of cultural memory at the University of Saskatchewan. Over many years, students have affixed paper clips, pens or keys to paper airplanes and have flung them up to the ceiling where the planes stick in the material lining the dome. A story circulates around the university that during the Second World War, young airmen receiving pilot training in the room wrote their names on paper airplanes and tossed them up to the dome. When the pilots went off to war, it was rumored that some families would visit frequently to see if their son's plane was still stuck to the ceiling. The story goes that if the paper plane fell, it meant the pilot had died in action. Although there is no evidence to suggest families came regularly to check on the paper planes, the story gives the lecture hall its nickname, the 'Airplane Room'.

The University Archives has a collection of 366 paper planes retrieved prior to the removal of asbestos from the ceiling in 1995, the oldest one dating from 1961. However, some undated ones are yellowed and brittle with age, and could be older. One states: "By the time you read this, I'll be rich." Another unsigned missile was apparently a suicide note reading: "After this message was written, a young gentleman committed suicide." The room is an important element defining the character of the university and associating it with a significant historical event.

The Thorvaldson Building is named after Thorbergur Thorvaldson, former head of the Department of Chemistry at the U of S, and inventor of sulfate-resistant cement. Early in the Twentieth Century, a problem emerged in Western Canada related to the corrosive action of sulfates, often present in soil and groundwater, on concrete structures. Over time, this emerged as a major concern for engineers, when structural failures began to occur in otherwise well-designed concrete structures. In 1919, a team lead by C.J. Mackenzie, Dean of Engineering, and Thorbergur Thorvaldson, conducted research on the causes of this phenomenon. Thorvaldson devised technique that changed the crystalline structure of concrete, rendering it immune to sulfate damage. The manufacturing process for cement was changed as a result of his work, and the durability of concrete structures significantly improved.



Figure 38. The dome of the 'Airplane Room' with the paper airplanes that inspired the room's name.



Figure 39. Thorbergur Thorvaldson in the Cement Testing Lab, 1958. The building was dedicated to Thorvaldson for his work in sulphate resistant concrete. Photo A-1640 retrieved from <http://sain.scaa.sk.ca/items/index.php/university-of-saskatchewan-archives;jsdiah>

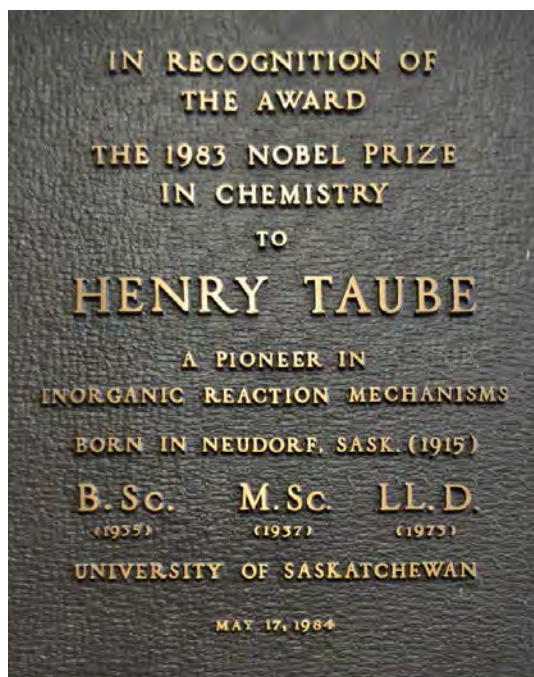

Figure 40. A plaque commemorating Nobel Prize Winner and University of Saskatchewan alumnus Henry Taube.

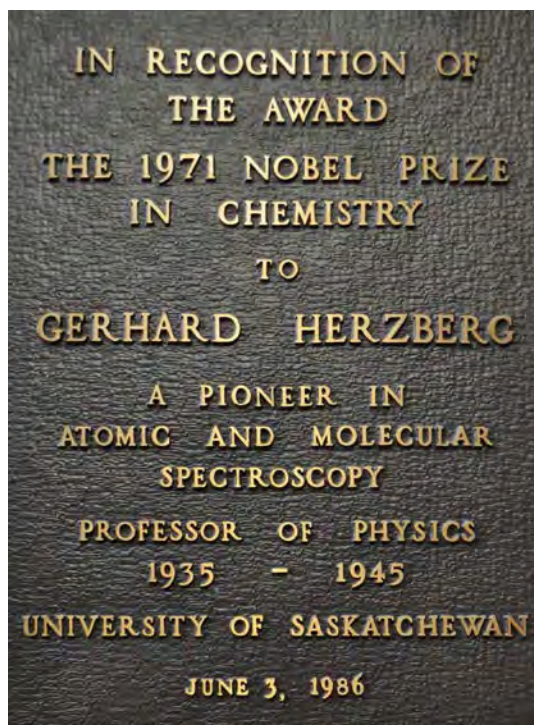

Figure 41. A plaque commemorating Nobel Prize Winner and University of Saskatchewan former faculty member Gerhard Herzberg.

Gerhard Herzberg can also be associated with the Chemistry Department and the Thorvaldson Building. He won a Nobel Prize in Chemistry in 1971 for his contributions to the knowledge of electronic structure and geometry of molecules. Herzberg was a member of faculty in the Physics Department from 1935-1945.

Two plaques in the building vestibule honor Nobel Prize winners Gerhard Herzberg and Henry Taube. (See Figures 40 and 41).

The Chemistry Building, as it was originally known, was officially opened in August 1924 during a special meeting of the British Association for the Advancement of Science. Representing both British and Canadian members, a group belonging to “all sections of the association,” took part in a CPR rail tour in order to get a “comprehensive view of the west,” (Hayes, 2007). The Association’s chemical section met in Saskatoon where the Chemistry Building was formally opened. Figure 42 depicts the scene.

3. Associated Objects

The paper airplanes in the ceiling of the Airplane Room, and those stored in the University Archives are character-defining elements of the Thorvaldson Building.

The remaining slate chalkboards and chart frames in the auditorium and laboratories are associated historical objects, as they are original to the building. The stone sinks that have been removed from use, but are being stored at the time of this report in the sub-basement, are also associated historical objects.

4. Supporting Documents

Avery, C. (2007). Oasis for Learning: Landscaping the University of Saskatchewan. *Saskatoon History Review*, 21, 11-24.

Delainey, W.P., Duerkop, J.D. & Sarjeant, W.A.S. (1982). *Saskatoon: A Century in Pictures*. Saskatoon: Western Producer Prairie Books.

Facilities Management Division (2011). Asset Resource Database [Data File]. Retrieved from [\\usask.fmddfs/files/iis/IIS_Public/ARS](http://usask.fmddfs/files/iis/IIS_Public/ARS)

Hayden, M. (1983). *Seeking a Balance: University of Saskatchewan, 1907-1982*. Vancouver: University of British Columbia Press.

Hayden, M. (1980). Where the 20's Didn't Roar – The University of Saskatchewan, 1920-1930, *Saskatoon History*, 1, 13-21.

Hayes, P. (April 20, 2007). Playing the Part of Host. *On Campus News*. Retrieved from http://news.usask.ca/archived_ocn/07-apr-20/4.php

Jasienuk, T., personal communication, August 17, 2012.

Murray, D.R. & Murray, R.A. (1984). *The Prairie Builder: Walter Murray of Saskatchewan*. Edmonton: NeWest Press.

Mysyk, W.K. & Kulyk, C.L. (2006). *Saskatoon's Stone*. Saskatoon: Houghton Boston Printers & Lithographers Ltd.

Office of the University Secretary. (Retrieved 2012). Ceremonies and Protocol: Flag at Half Mast. Retrieved from http://www.usask.ca/university_secretary/ceremonies/flag.php

Ralko, J. (2004). *Building Our Future: A People's Architectural History of Saskatchewan*. Calgary: Red Deer Press.

Silversides, B. (1985). Saskatoon Architects 1905-1920. *Saskatoon History*, 3, 20-37.

University of Saskatchewan Archives. Buildings and Grounds Department Series I. Chemistry Building.

University of Saskatchewan Archives. (Retrieved 2012). Events in the History of the University of Saskatchewan. Retrieved from http://scaa.usask.ca/gallery/uofs_events/articles/1924.php

University of Saskatchewan Archives. (Retrieved 2012). *Campus Buildings: Thorvaldson Building*. Retrieved from http://scaa.sk.ca/gallery/uofs_buildings/.



Figure 42. August 22, 1924. The Chemistry Building (later known as the Thorvaldson building) was opened by the Premier of Saskatchewan, C.A. Dunning. Other dignitaries on the steps of the Chemistry Building include W.C. Murray, F.W.G. Haultain, S. Basterfield, Sir D. Bruce, W.R. Motherwell and S.J. Latta. Photo A-241, retrieved from <http://sain.scaa.sk.ca/items/index.php/university-of-saskatchewan-archives;isdiah>

5. Summary of Character - Defining Elements

Materials

- greystone walls
- Indiana limestone trim and decoration
- granite base and exterior stairs
- red terracotta floor tile
- cast iron radiators
- main stair: cast and wrought iron balustrade, bronze handrail, slate treads
- slate chalkboards
- slate roof tiles
- slate thresholds
- quarter-sawn oak doors, trim, and millwork
- lead-covered ventilation louvres
- brass screen and ventilation grilles in Airplane Room

Form & Style

- original building is distinct from later additions, and visible on three sides.
- central volume with wings
- carved stone detailing
- gothic arches
- Guastivino dome
- vaults
- tower
- parapet
- crenellation
- quoining
- spandrels
- plaques

Location

- original location and orientation

Spatial Configuration

- wings with double loaded corridors
- triple height auditorium with dome
- central staircase
- original plan never realized



Structural Systems

- Guastavino dome
- steel trusses in attic

Uses

- Chemistry Department
- laboratories, classrooms, lecture theatre & offices
- flag protocol

Cultural & Chronological Associations

- Thorbergur Thorvaldson, inventor of sulphate-resistant concrete
- Nobel Prize Winner Henry Taube



021

President's Residence



021

President's Residence

Alternate Names

N/A

Architect(s)

David R. Brown and Hugh Vallance, Brown and Vallance Architects, Montreal

Builders

George Wiseman, Robert Neil, supervised by Alexander R. Greig

Construction Dates

1913

Recognition

University of Saskatchewan 'A' Listed

1. Statement of Significance

The President's Residence has significant heritage value due to its age, use, cultural associations, architectural quality and state of preservation. The President's Residence was built to provide a home for the first President of the University of Saskatchewan and his successors. The first President, Walter Murray, lived in the house from the time of its completion until the end of his tenure in 1937. The building's association with Murray is of historical significance. The use of the building as a residence has been historically continuous. The home has also been host to several notable events, including a visit by Queen Elizabeth II in 2005.



Figure 1. L to R: 'Greystone' and Indiana limestone.



Figure 2. The President's Residence, 1918. Photo A-711, retrieved from http://scaa.sk.ca/gallery/uofs_buildings/

The architecture of the President's Residence is consistent, in terms of style and materiality, with other historic places on the University of Saskatchewan campus. Its craftsmanship is of exemplary quality. The building was originally to cost \$32,000, but the final total came to \$44,615. The cost of the house is significant: at the time the house was worth more than double that of any other home in Saskatoon. President Murray was embarrassed by the extravagance, but his requests to reduce the cost went unanswered.

Note: The President's Residence is configured with floors numbered Basement, Ground Floor, Second Floor & Attic. This report follows the same convention.

2. Character - Defining Elements

2.1 Materials

The President's Residence is primarily constructed of the rough-faced dolomitic limestone commonly known as 'greystone', and familiar to much of the campus. The material is significant as it was gathered from the Saskatchewan prairie near the site of the university. Surrounds and other cut stone details are rendered in Indiana limestone (Figure 1). (For further information on building stones used at the U of S, refer to ['Appendix : Stone.'](#)) Slate tiles clad the roof, and at the eaves, exposed wooden rafter ends are visible. Copper eaves troughs and downspouts carry water from the roof to the ground. Figure 3 shows the detailing of the eaves.



Figure 3. Copper eaves troughs and exposed wooden rafter ends.



Figure 4. Quartersawn oak window frames with brass hardware and leaded glass.



Figure 5. The oak staircase.

A greystone fence encloses a garden on the east side of the Residence. A wooden balustrade sits atop the fence which is entered through a wooden gate. The wooden portion of the fence remains only on the northern portion of the enclosure. To the east of the fence is the greystone garage. The original garage was removed and a new one constructed in 2010. Stone from the original garage was re-used in the construction of its replacement, as was the copper crown atop its roof. A wood-clad addition to the east side of the house was constructed in 1989 in order to expand the kitchen.

The interior finishes and materials of the home have significant heritage value. Doors are crafted from quarter sawn oak as are cabinetry, seating, picture and crown moldings. In the attic the doors have been refinished with paint. Many of the glass cabinet doors and exterior windows feature leaded glass. Interior window frames, door surrounds, hearth mantles and baseboards are also made of quarter-sawn oak. Brass fixtures adorn doors and windows. Figure 4 shows the combination of oak, bronze and leaded glass used for windows.

A central staircase climbing from the basement to the ground floor, and also constructed of quarter sawn oak, is a significant character-defining element (Figure 5). Fireplace hearths are made from glazed tile set flush with the surrounding floors in varying buff and yellow colors. As shown in Figure 6, some of the hearths still retain their cast iron grates. Controls for the flue dampers are in bronze. All mantles are wooden except for the basement fireplace shown in Figure 7 which is made of granite. Brass hardware is also used on all windows and doors in the house. The brass materials are in an excellent state of commemorative integrity and contribute to the heritage value of the house.

The walls are clad in painted plaster. According to a common practice for this age of building, the plaster was mixed with horse hair in order to achieve a stronger material. The ground floor has maintained its original wooden flooring while the first floor and a portion of the basement have received new wooden flooring. In many cases a new hardwood floor has been installed. This is discernible at points where the glazed tile mantle sits below the level of the floor. The original flooring material likely exists underneath.

The pantry adjacent to the kitchen is unique in that its wooden cabinets and trim differ from those in the rest of the house. The pantry cabinets and door surrounds are made out of stained maple (Figure 8). The location of the wood suggests that the house was designed with different materials according to the purpose of the space. The pantry was intended chiefly for use by servants and so maple may have been used instead of oak because service rooms were not intended for public view. This interpretation is reinforced by the hardware on the cabinetry. Brass hardware is found throughout the residence on all windows and doors; however the style of hardware in the pantry is more utilitarian, implying a lower importance. The pantry also features a washboard countertop. The wood of the countertop is a lightly stained oak into which an arrow pattern has been carved, for drainage (Figure 9). A wooden insert has been installed where a sink used to be. The wood and brass in the residence exist in an excellent state of commemorative integrity.

In 2012, the ground floor kitchen underwent a renovation which saw it returned to a material palette reflective of its original design. Quarter sawn oak cabinetry with glass doors was installed. The kitchen and nearby sunroom doors were replaced with oak counterparts. These renovations did not preserve original materials, but replaced contemporary materials with more historically appropriate ones. (See Section 2.3 Style).

2.2 Form

Organized around a central hallway, the President's Residence is compact in form. The building reaches three stories in height above the ground. As a house, the scale of the President's Residence is smaller from most buildings on campus. However, without any other nearby structures to relate to, the President's Residence seems imposing. Its relatively small footprint and great height serve to enhance this effect. The Residence is designed to create a focus for its prominent river front site as shown in Figure 10. Many other early campus buildings were designed to form and enclose outdoor courtyards. The President's Residence is not shaped to frame any outdoor space. Rather, it creates a focal point of the land on which it sits.



Figure 10. The form of the President's Residence. Photo A-3400, retrieved from http://scaa.sk.ca/gallery/uofs_buildings/



Figure 6. Yellow glazed tile hearth and cast iron fire grate.



Figure 7. The granite fireplace.

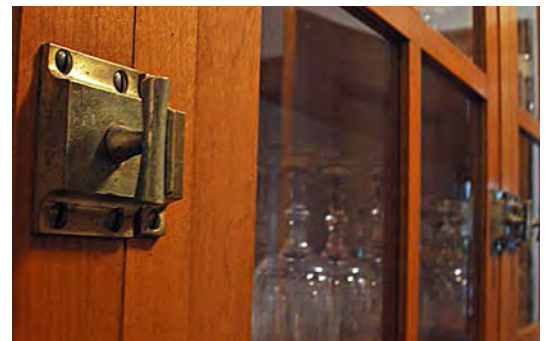

Figure 8. Maple cabinetry with utilitarian brass latches in the pantry.

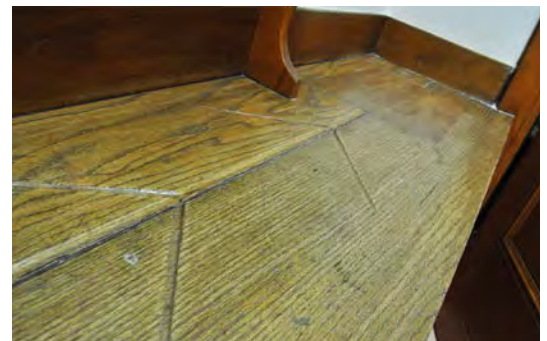

Figure 9. Oak countertop with carved drain board.



Figure 13. An arched doorway and surround sit atop a bay window.



Figure 14. Limestone corbels supporting the underside of a chimney.



Figure 15. Ornamental bracket on a copper downspout.

The form of the President's Residence has been amended over the years with numerous renovations. However, no deletions have been made to the original form, which is still discernible and in good commemorative integrity. The most extensive change has been to the building's east façade which has been extended to form a larger kitchen and an enclosed sun porch.

2.3 Style

The President's Residence is in the Arts and Crafts style with elements of the Collegiate Gothic. The Arts & Crafts was a primarily domestic style of architecture of the latter half of the 19th and early 20th centuries, that along with the Collegiate Gothic, formed part of the broader Victorian Gothic revival. The Arts & Crafts movement favoured traditional forms of craftsmanship, simple forms, manual production techniques and decorative motifs recalling mediaeval art. This style shares many characteristics with the Collegiate Gothic used elsewhere at the university, and the President's Residence blends elements of both styles.

The President's Residence has numerous Arts & Crafts character-defining elements, including pitched roofs with gable ends, bay and dormer windows, and various stone details. The slate tile material used to clad the roof is an element defining the character of the building. Punctuating the roofline are dormer windows. Both character-defining elements are shown in Figure 11. Oriel windows and bay windows animate the elevations (Figure 12). The small, archery style window above it is also characteristic of the gothic style. Above one bay window, a walkout balcony on the first floor is accessed through an arched doorway which contributes to the Gothic character of the building. (See Figure 13). Arches can also be seen framing one of the covered balconies. The



Figure 11. Dormer windows protrude from a roof clad in slate.



Figure 12. Oriel window with an arched window above it.

stonework of the exterior walls features quoins, buttresses and various other character-defining elements. The decoration applied to such utilitarian features as downspouts and chimneys, shown in Figures 14 and 15 respectively, are also elements of the Gothic Revival styles. Corbels such as those shown in Figure 14 are also used on some of the fireplaces.

The arch and vault are architectural elements characteristic of Gothic Revival styles. The ground floor corridor of this building has a vaulted ceiling as shown in Figure 16. The entrance facing the staircase on the ground floor corridor is framed by a small arch intersecting the vaulted ceiling of the ground floor corridor (Figure 17). Some fireplaces also feature arched mantles, as shown in Figure 18.

Due to its use, the President's Residence features numerous Arts and Crafts elements which serve to define its residential character. Many of the glass doors and windows feature character-defining leaded glazing with multiple small lites. This character-defining glazing is also found on interior cabinetry as shown in Figure 19. Doors with a glazed panel across their top third are particularly characteristic of the Arts & Crafts style (Figure 20). The motif cut into the wooden staircase is another characteristically Arts & Crafts element as is the row of three tall, narrow windows shown in Figure 21. Many of the windows of the building are operated by espagnolette bolts. These fittings (pictured previously in Figure 4) are character-defining elements.



Figure 18. An arched mantle.



Figure 19. Built in cabinetry features arts and crafts details.

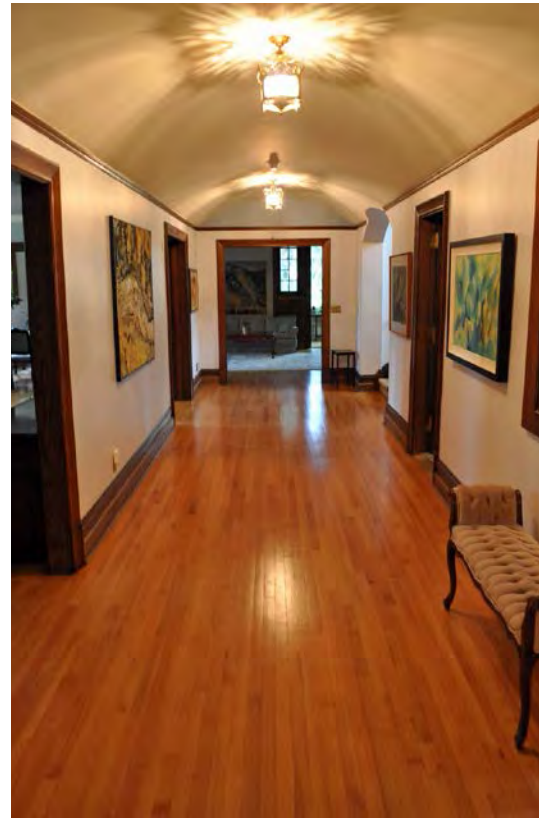

Figure 16. A vaulted corridor.

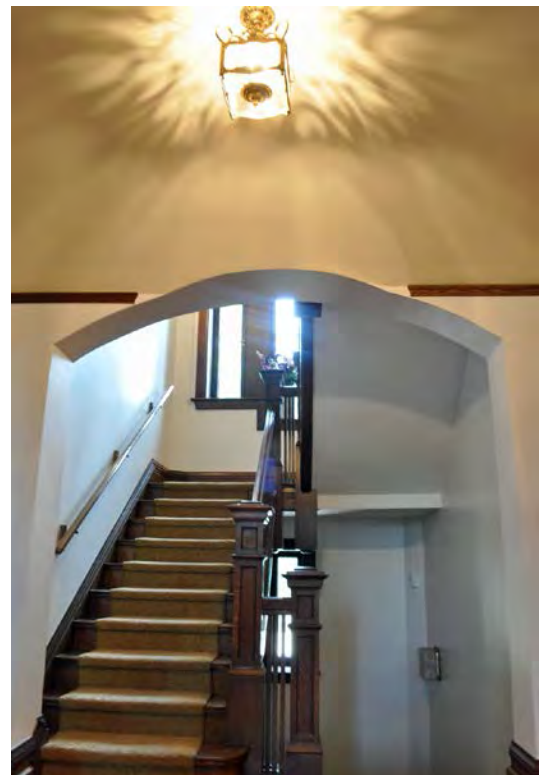

Figure 17. Two intersecting arches marks the entrance to the staircase.



Figure 21. Light shining through an Arts and Crafts style window.



Figure 22. Arts and Crafts style cabinetry.



Figure 23. Additions made to the east side of the residence.

In 2012, the kitchen was renovated with new oak cabinetry matching the details of the original maple pantry cabinets. Cabinet pulls were replicated from the pantry. Crown and door moldings were copied from elsewhere in the house. Figure 22 illustrates the quarter sawn oak cabinetry detailed in the Arts & Crafts style.

Other renovations to the President's Residence have been carried out in a modern idiom. The most salient example is on the east façade, shown in Figure 23. A sun porch enclosed in wood is distinctly modern in comparison to its traditional backdrop. Other examples of this are seen in the enclosure of porches on the north and west sides with modern glazing systems. The 2012 renovations saw some of the doors on the east side replaced with more historically sympathetic counterparts.

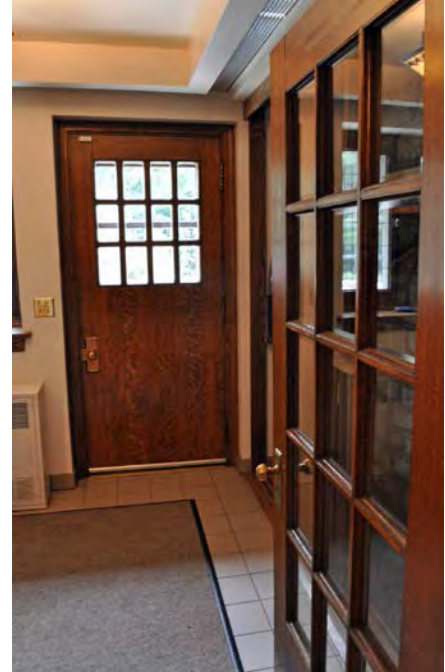

Figure 20. Arts and crafts style doors.



Figure 24. This view, ca. 1913, shows the President's Residence in the final stages of construction and gives an overall impression of the stylistic elements of the exterior of the residence. Photo A-707, retrieved from http://scaa.sk.ca/gallery/uofs_buildings/

2.4 Location

The President's Residence was located generally in accordance with the 1909 campus plan, as shown in Figure 25. Situated on a point on the east bank of the Saskatchewan River, the residence has one of the most prominent locations in the city. The visibility of the residence from across the river is a character-defining element of its location that announces the university's presence to the rest of the city.

2.5 Spatial Configuration

With a floor area of over 10,000 square feet, the President's Residence constitutes a large home, especially by the standards of its time. The building consists of a basement, and three above ground, including an attic. The two principle stories above ground are both arranged around a central corridor. The corridor on the main floor does not have any windows; however, spaces adjacent to it such as the stairwell and entry bring in natural light (Figure 21).

Originally, the layout of the ground floor was very parceled, with numerous partition walls defining separate rooms. Figure 26 shows the ground floor as it originally existed. This has been well maintained with a few exceptions; the front porch has been enclosed to create an entrance hall and the library and reception room have been combined. The result is a much larger and more open space.

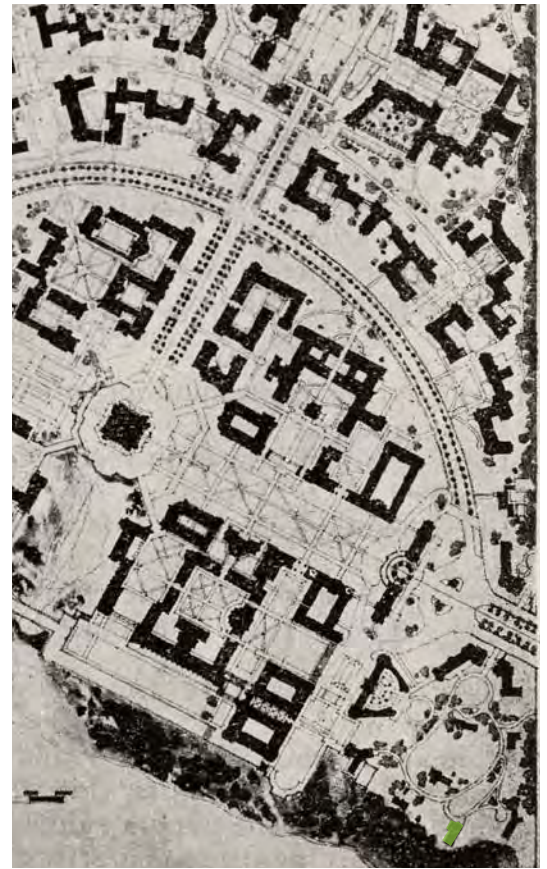

Figure 25. The location of the President's Residence is indicated in green on the 1909 Campus Plan by Brown and Vallance Architect's. North is represented to the left.

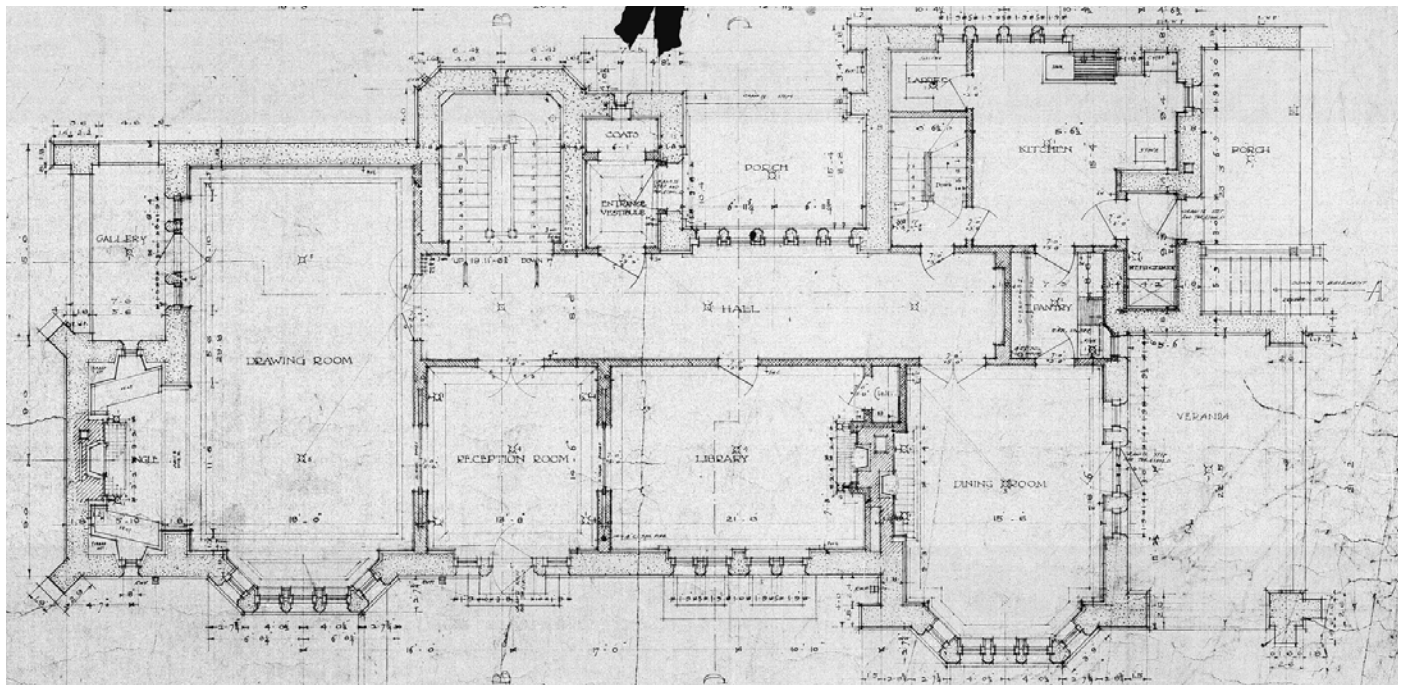

Figure 26. The ground floor plan of the President's Residence. The wall between the library and reception room has since been removed. The east side of the building has been extended. Retrieved from Facilities Management Division Asset Record System, File RP-4-T.

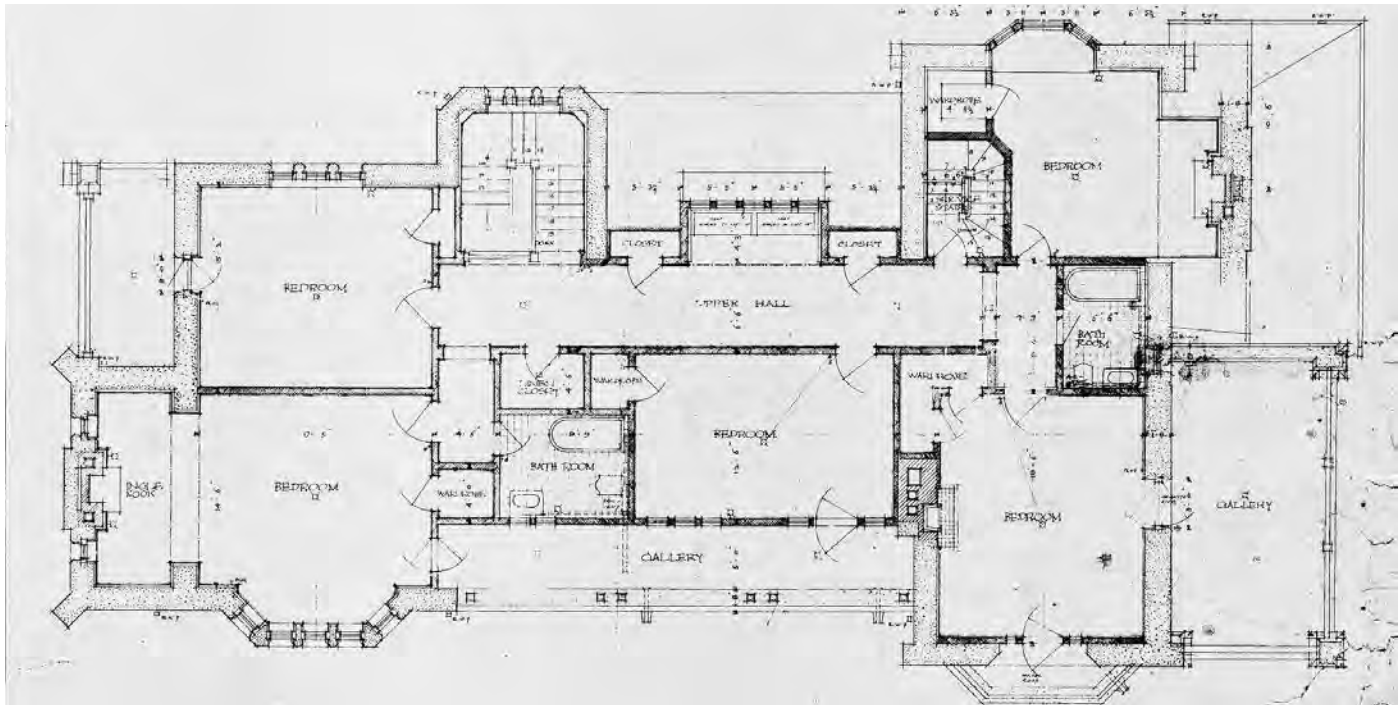

Figure 27. The second floor plan as it was originally constructed. Retrieved from Facilities Management Division Asset Record System, File RP-5-T.



Figure 28. Oriel window seat.

On the east side of the home, the interior of the house has been expanded by the addition of a sunroom and an addition to the kitchen. With these renovations, the original spatial configurations have been altered. For example, an access to the basement from outdoors used to be located at the bottom of an exterior set of stairs. This set of stairs is now enclosed.

The second floor of the residence was even more subdivided than the ground floor. The original floor plan is provided in Figure 27. Every room was separate with a single entrance. Like the ground floor, all of these separate rooms were organized around a hallway. Natural light was brought into the corridor by virtue of the glazing shown in Figure 21, and by dormer windows adjacent to the hall. Several window seats exist on the second floor, and are character-defining elements (Figure 28).



Figure 29. The renovations made to the former balcony.

Figure 27 illustrates the second floor plan of the President's Residence as it was originally conceived. The second floor has undergone some changes in configuration. A balcony on the south side of building has been enclosed. Figure 29 shows the enclosed balcony as it appears from outside. The bathroom adjacent to the balcony has been renovated into a kitchenette. The linen closet directly off the main corridor has been enlarged and converted into a washroom. The south west bedroom has had closets installed. Figure 30 provides a plan of the first floor with the renovated kitchenette included.

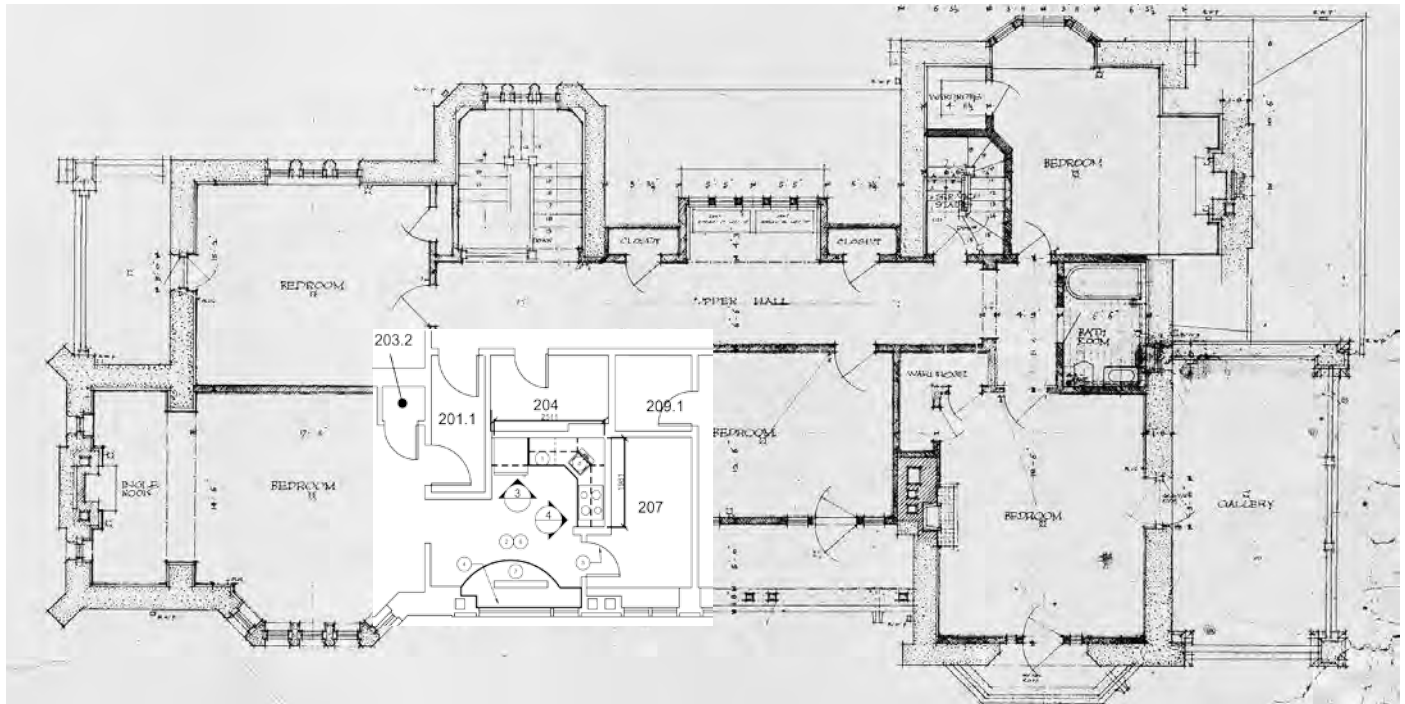

Figure 30. The second floor plan with the renovated kitchenette superimposed over it. This image is accurate as of 2011. Further renovations took place in 2012. Retrieved from Facilities Management Division Asset Record System, File RP-5-T.

The President's Residence features a number of balconies that are character-defining elements of its spatial configuration. A small walkout space on top of a bay window is shown near the bottom right corner of Figure 27, and from the exterior in Figure 13.

The attic floor comprises much less living space than the other floors. Most of its area forms a large open storage space. The upstairs living quarters are on the east side. The two bedrooms and washroom on this level are much smaller than those on the second floor. The configuration of these rooms is original to the building.

This house has seven fireplaces, all of which have been maintained. Although they don't function as they once did to provide heat, they still serve as interior focal points. Their locations, materials and form have been very well maintained and retain their commemorative integrity. The fireplace on the ground floor off the Drawing Room carries particular significance with respect to spatial configuration. Oak seating is built around this fireplace to form an angle nook. Figure 31 shows this configuration in plan.

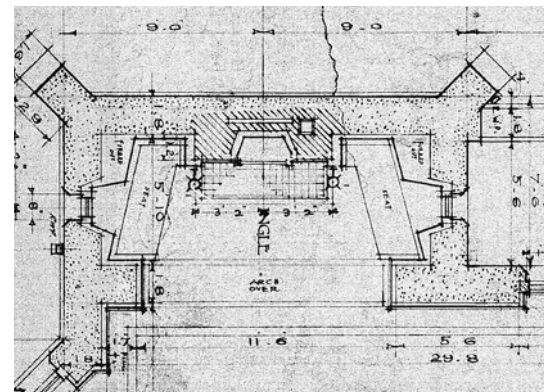

Figure 31. A hearth with built in oak seating forms a nook. Retrieved from Facilities Management Division Asset Record System, File RP-4-T.



Figure 32. Main staircase. Photo A-5508, retrieved from http://scaa.sk.ca/gallery/uofs_buildings/



Figure 33. A 1930's Christmas Party held for the faculty and their children in the President's Residence. Photo A-2848, retrieved from http://scaa.sk.ca/gallery/uofs_buildings/

This house features two staircases; one was intended as a service stair to be used only by the house staff. This stairwell provides the only point of access to the attic. The attic was therefore likely intended to serve as servant's quarters. A much wider and grander staircase shown in Figure 32 was intended to accommodate the President's family and their guests. This staircase features a two storey window that allows for an abundance of natural light to enter the ground level, basement and first floor.

2.6 Systems

Load-bearing exterior stone walls, supplemented by an interior wooden post and beam system, form the structure of this house. Stone foundation walls sit on concrete footings. The exterior walls of the house thicken visibly towards their base, expressing their function as structural elements. This is also visible in the thickness of the basement walls in comparison to the walls of the stories above. The interior walls of the basement are made of brick, and some are load-bearing. Stone buttresses on the corners of the exterior walls are decorative rather than structural. The wooden post and beam system is especially visible in the basement, where the posts meet beams in the ceiling to support the weight of the upper stories.

2.8 Use(s)

The President's Residence has had its historical use preserved to the present day. It is also often used to host events and receptions. Historically, Walter and Christina Murray used to hold an annual Christmas Party for the faculty and staff. More recently, the residence was host to the Queen on her 2005 visit.

With the building's use as a residence and a venue for receptions, the house serves two purposes. Its hospitality function has always been carried out on the ground floor of the house. Figure 34 shows an early example of the house being used for entertainment. The upper floors also maintain their use as personal living quarters.

Interesting to note is that the attic was designed for use by servants. Although the servants' quarters were built into the house, no record of live-in servants exists, so it appears that the attic space never served this purpose. From 1975 to 1980 the President's Residence attic floor was used to house students. Two students shared the larger of the two bedrooms and used the smaller of the rooms for a lounge and study space.

2.8 Cultural & Chronological Associations

The President's Residence was home to the university's first President, Walter Murray, and carries with it this association. The drawings prepared by Brown and Vallance Architects label the building 'Residence for Dr. Murray'.

3. Associated Objects

A grandfather clock stands at the east end of the ground floor corridor (Figure 35). The clock was pictured in this location as early as the 1930's (Figure 34). No record of the clock's purchase by either Dr. Murray or the university exists, so it is not known whether it is original to the house.

The ground floor dining room holds the original set of china purchased by Walter Murray in 1913 and used by President Murray and his wife Christina.



Figure 36. Indian tree pattern found on the Murray's china set.

This Spode china can be identified by its Indian tree patterning pictured in Figure 36. A basement cabinet may also hold some heritage value in its contents. Green colored depression-era glass is characteristic of the time in which the Murray's inhabited the house. Some of the china has no markings on its underside; usually a sign of older antique pieces.

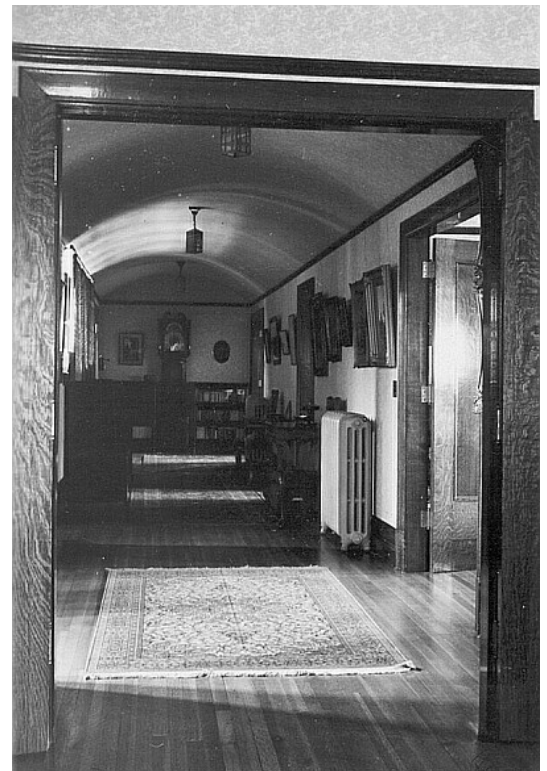

Figure 34. Visible at the far end of the corridor is a grandfather clock. Photo A-5507, retrieved from http://scaa.sk.ca/gallery/uofs_buildings/

4. Supporting Documents

FacilitiesManagementDivision (2011). AssetRecordSystem [Data File]. Retrieved from [\\usask.fmddfs\files\iis\IIS_Public\ARS](http://usask.fmddfs/files/iis/IIS_Public/ARS)

University of Saskatchewan Archives. Board of Governors Agendas, University of Sask. 1911.

University of Saskatchewan Archives. (Retrieved 2012). *Campus Buildings: Presidents Residence*. Retrieved from http://scaa.sk.ca/gallery/uofs_buildings/

University of Saskatchewan Archives. Jean Murray Fonds AII1(b) Finances.

University of Saskatchewan Archives. Jean Murray Fonds EIIC32 President's Residence.

University of Saskatchewan Archives. Presidential Papers Series V.RG2001.5.

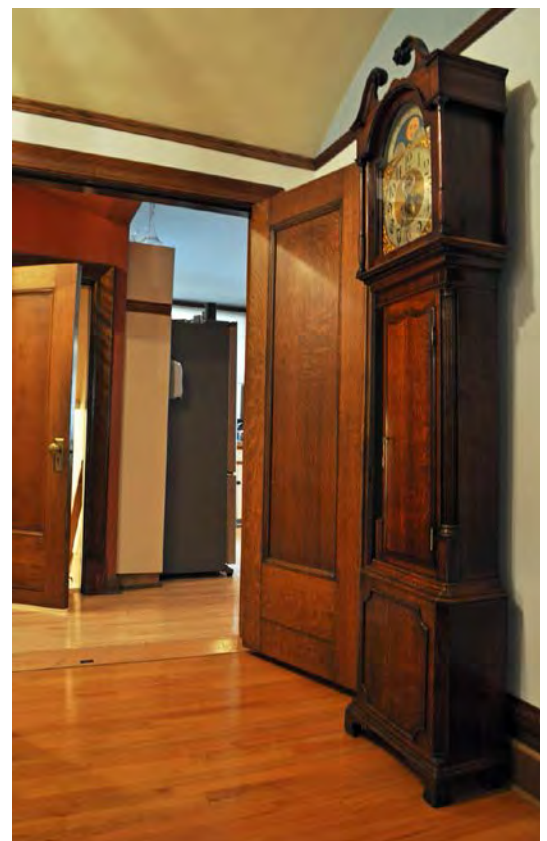

Figure 35. The clock still stands at the east end of the ground floor corridor.

5. Summary of Character - Defining Elements

Materials

- greystone walls
- indiana limestone ornamentation
- slate tile roofing
- quarter sawn oak doors, baseboards, moldings, cabinetry
- wooden floorboards
- maple pantry
- copper downspouts
- steel
- bronze and brass fixtures
- red clay terra cotta
- plaster (with horse hair)
- granite fireplace
- glazed tile hearth
- metal grates

Form

- large scale
- deep floor plate

Style

- elements associated with the Arts & Crafts style
- pitched slate roofs with gable ends
- corbels
- dormer windows
- bay windows
- oriel windows
- arches (mantles, entries, doors, windows)
- vaults (corridor)

Location

- according to 1909 campus plan
- visibility and prominence on riverbank



Spatial Configuration

- arrangement around central corridors
- natural light from glazing in circulation spaces
- parcelled interior
- outdoor spaces (porches, galleys)
- heated bathroom floor
- hearths (with built in oak seating)
- stairwells (service stair and guest stair)
- window seats

Systems

- piers

Use(s)

- residential on second and third floor
- entertaining on main floor

Cultural & Chronological Associations

- Dr. Walter Murray



025

Observatory

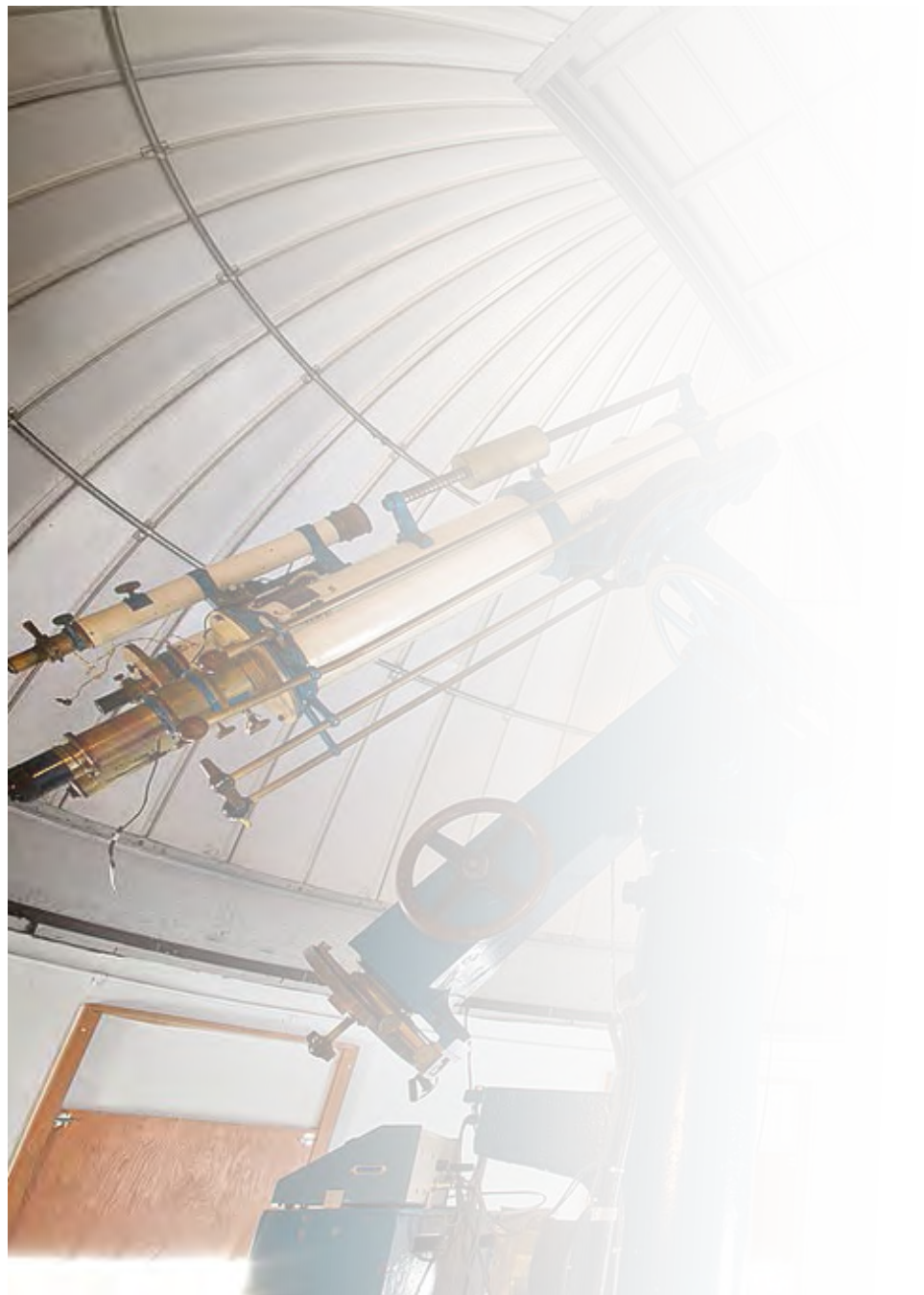

025

Observatory

Alternate Names

N/A

Architect

Gentil J.K. Verbeke

Builders

R.J. Arrand Contracting Company

Construction Dates

1928-1930

Recognition

University of Saskatchewan 'A' Listed

1. Statement of Significance

The University of Saskatchewan Observatory is a charming building and an iconic symbol of the University of Saskatchewan. In his annual report, the first president of the university, Dr. Walter Murray called the Observatory, “a gem of beauty and convenience,” and cited the Observatory and the [Memorial Gates](#) as the most beautiful structures on the campus. The Observatory was constructed in two parts between 1928 and 1929; the tower was built first, followed by the classroom. The telescope housed inside was funded by private donations. The Observatory’s most important character-defining elements are its distinctive domed tower and its Collegiate Gothic style and materials. The building is composed, like many at the university, primarily of local ‘greystone’. Indiana Limestone, granite, copper and oak complete the list of materials. This building has been used continuously as an observatory since its construction. Both its exterior form and its basic interior spatial configuration have been maintained intact since its construction. For these reasons, the Observatory is a significant heritage asset of the University of Saskatchewan.

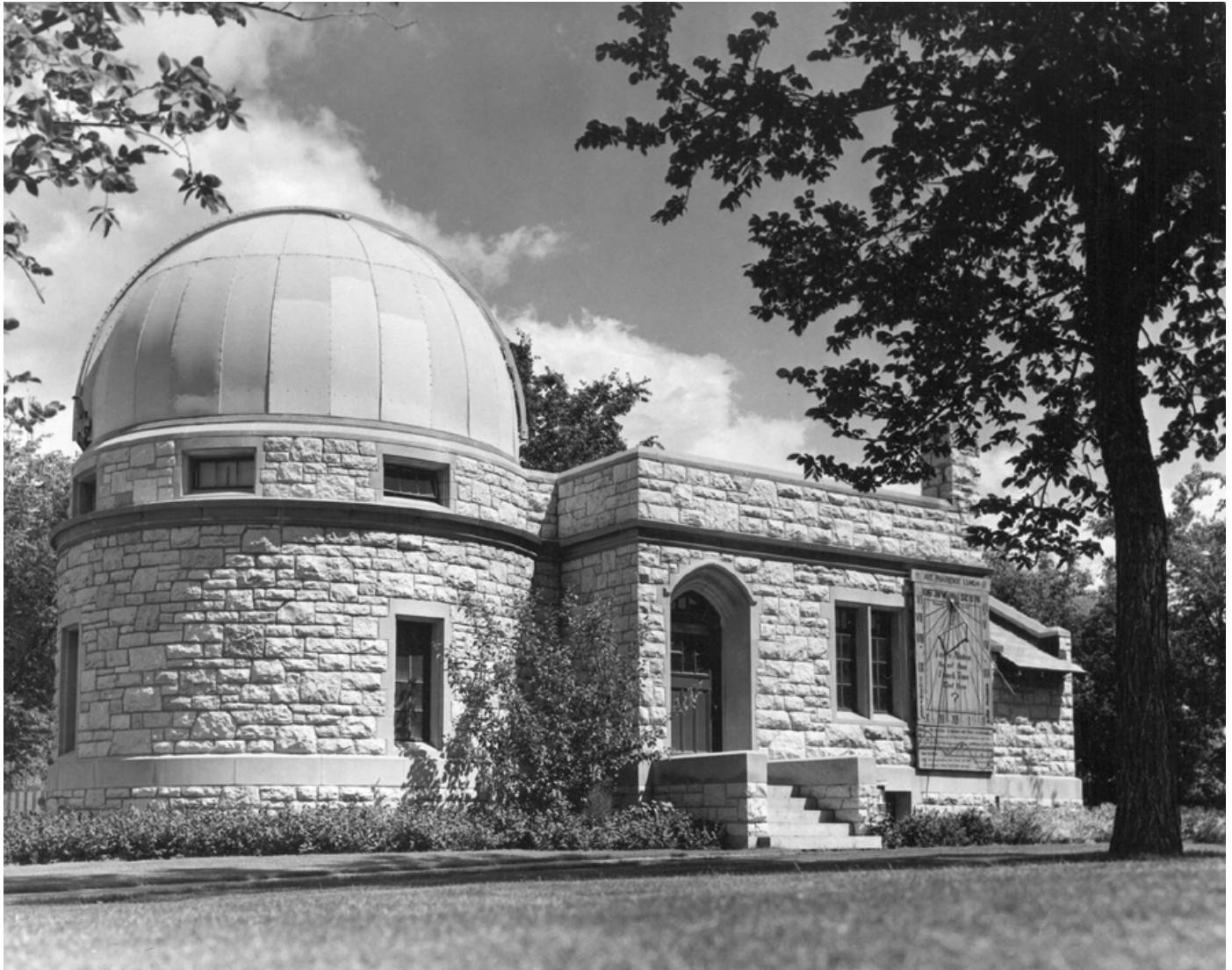

Figure 1. The Observatory in 1966 with its original dome. A sundial is visible on the exterior. Photo A-4517, retrieved from http://scaa.sk.ca/gallery/uofs_buildings/

2. Character - Defining Elements

2.1 Form

Although diminutive in scale, the Observatory is composed of three distinct volumes, corresponding to its three principal rooms. A circular form with a domed roof houses the telescope, a larger central volume with a flat roof originally accommodated a lecture theatre, and a smaller volume, rectangular in plan and with a pitched roof, housed a transit. The 18-foot diameter dome (Figure 1) and its stone tower are important character-defining elements, identifying the building as an observatory. The three volumes are arranged symmetrically about a longitudinal axis.

The human scale of the building is also a formal character-defining element.



Figure 2. Granite steps, cut limestone trim and greystone wall.



Figure 3. Copper dormer roofing, decorative wooden rafter ends.



Figure 4. Steel observatory dome.

2.2 Materials

The exterior materials of the building, particularly its ‘greystone’ walls, define the Observatory as part of the University of Saskatchewan. Indiana limestone was used for decorative trim, while the entrance steps and building base are made of granite. Figure 2 shows these materials.* The most prominent feature of the building is its domed observatory roof, clad in aluminum. This dome replaced the original dome of wire and papier-mache in 1976 (University of Saskatchewan Archives. U of S Observatory, Kennedy Additional - Box 7). The flat roof of the central volume is concealed behind a stone parapet, but is roofed with tar and gravel. The volume corresponding to the transit room features a pitched roof which was originally clad in slate tiles, but now has asphalt shingles. A unique material feature of this building that has survived is the copper dormers. These are retractable, and originally provided access to the sky for the transit. The copper roofing has weathered over time, turning a deep shade of green and brown, as shown in Figure 3. The same material is found along the roof ridges, flashing and gutters. Decorative wooden rafter ends appear under the eaves (Figure 3). Figure 4 shows the material of the current dome.

Windows, shown in Figure 5, are framed in rolled steel. The interior window surrounds are made of oak and the windows are operated with bronze or brass hardware. The windows on the upper level are in excellent commemorative condition save for a few broken panes in the transit room. The interior oak doors of the building all exist in excellent commemorative condition save for the door to the telescope room which has been replaced. Figure 6 shows the material of one of the original doors. The surround to the immediate right of the entrance shows some wear. The entrance

door itself appears to have been replaced in kind. The new door is lighter in color than its interior counterparts; however, it appears to have been constructed to match the original in material and design. The door surround appears to be original.



Figure 5. Steel framed window with brass hardware and an oak surround.

* For further information on building stones used at the U of S, refer to [‘Appendix: Stone’](#).



Figure 9. Basement window, painted over.

The floors of the building no longer contain heritage value, having undergone renovation to vinyl composite tiling. The walls of the upper level maintain heritage value with the maintenance of brick wainscoting topped by plaster on lath and crowned with an oak molding. Figure 6 shows the brick. Specifications show that the interior

of the classroom was clad in 'Tee Pee Moka Brick.' The former classroom has retained a blackboard made of slate and framed in oak; a significant character-defining element that has been well maintained. Throughout, the Observatory has character-defining brass ventilation grilles with brass pulls.

The commemorative integrity of the basement materials have been compromised. Brick walls, windows, brass grilles and pulls have been painted. Figures 9 and 10 show cases in which painting has compromised material integrity. The space under the dome has been completely re-clad to become a museum space. See Section 2.5, Spatial Configuration.



Figure 10. Concrete wall and brass grille that have been painted.



Figure 6. Brass plated steel doorknob.

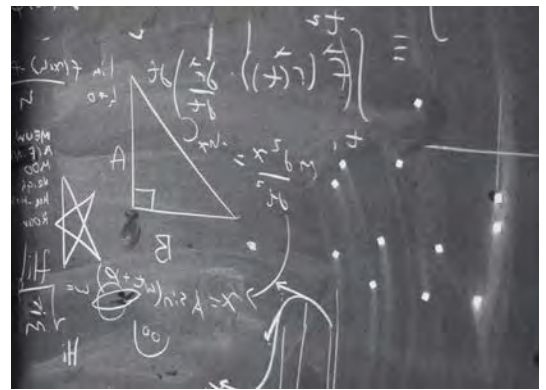

Figure 7. Slate chalkboard

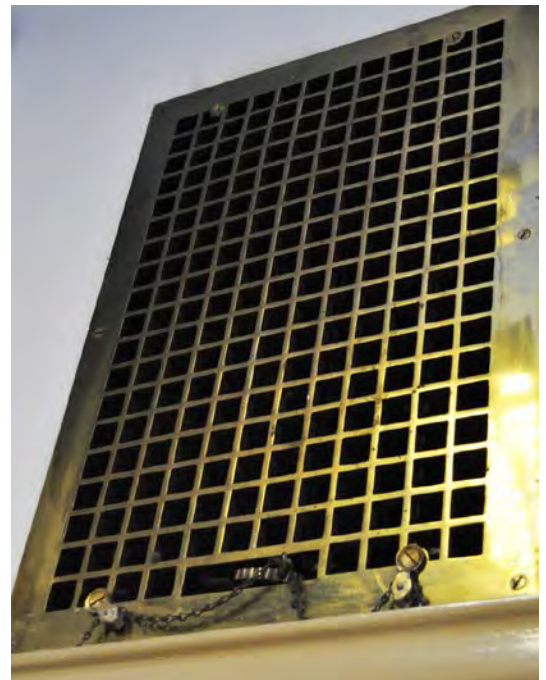

Figure 8. Brass grille.



Figure 11. Arched transom and door frame.



Figure 12. Oak interior door.

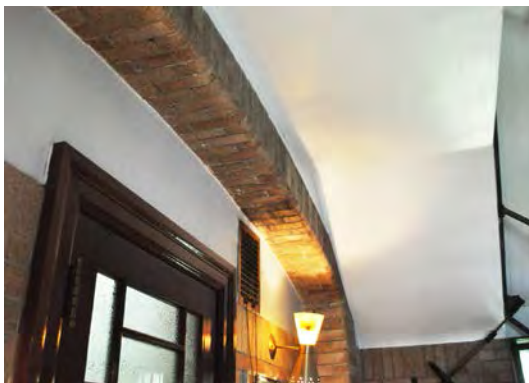

Figure 13. The brick arch in the transit room.

2.3 Style

The Observatory is nominally Collegiate Gothic in style, although its detailing is relatively subtle. Limestone string coursing, stone parapets and an arched entrance door are its most prominent gothic features. (See Figure 11).

The entrance to the Observatory is Gothic in style, with a Gothic arched transom. See Figure 11. Some Arts and Crafts detailing is also discernible in the design of the door, which features lites along its top third. This door is a character-defining element due to its material, design and craftsmanship. The original oak interior doors also have heritage value - see Figure 12.

2.4 Location

The observatory does not appear on the 1909 Campus Plan by Brown and Vallance; however, the location of the building has not changed since its construction. The location and orientation of the building is delicate as it provides an unhindered view of the night sky for both telescopes (Figure 14). Unlike most contemporary buildings at the university, the Observatory is oriented according to the cardinal directions, presumably in support of its function.

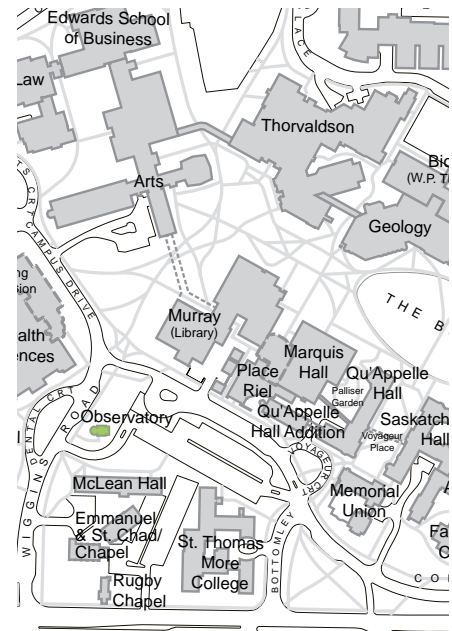

Figure 14. The location of the Observatory is indicated in green on this contemporary campus map.

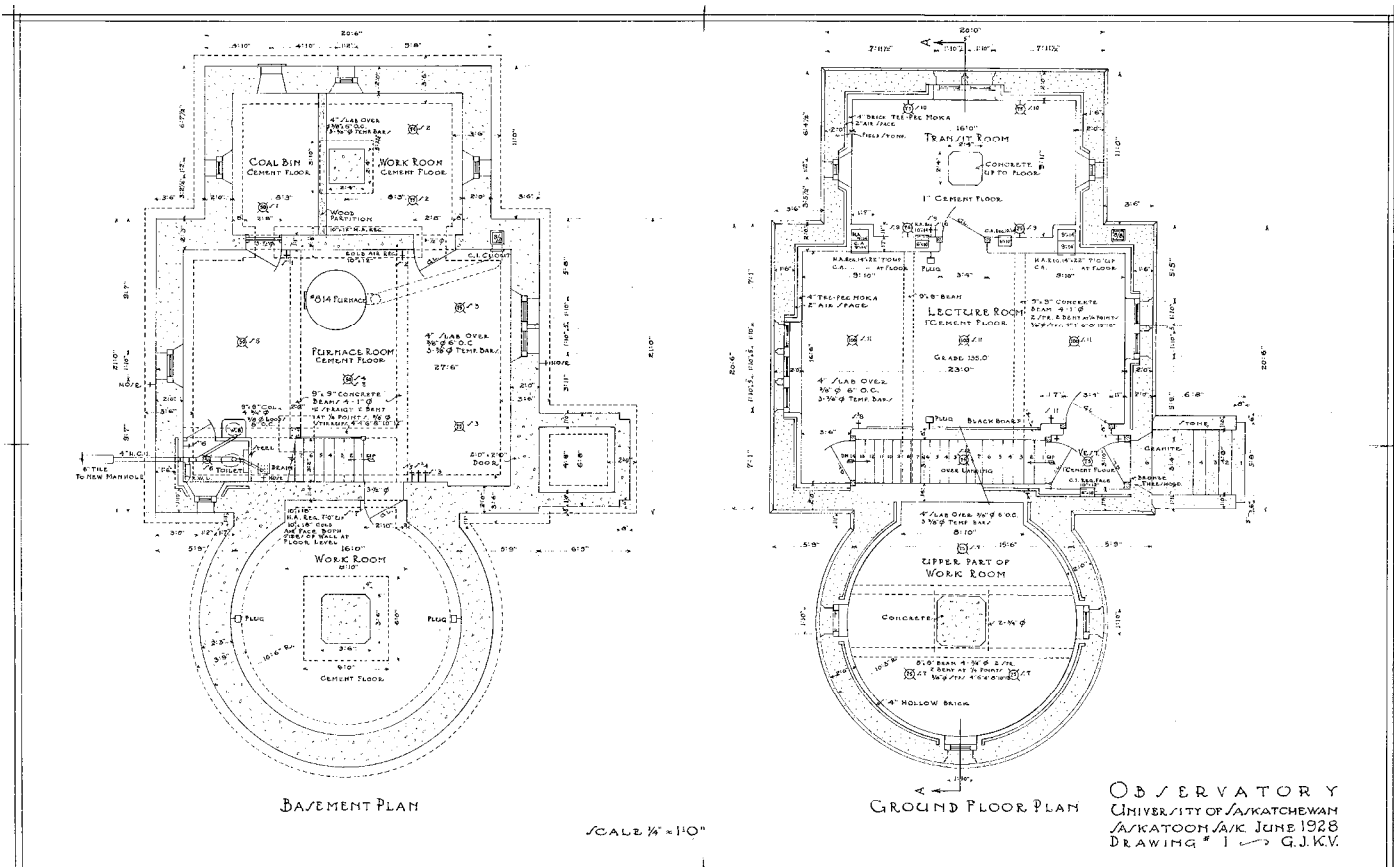

Figure 15. The original floor plans for the Observatory. Retrieved from Facilities Management Division Asset Record System, File O-2-T.

2.5 Spatial Configuration

The original floor plans of the building are shown in Figure 15. The ground floor has maintained its commemorative integrity; the layout is still as it was originally. Shown in Figure 16, the round telescope room is a character-defining room due to its unique curved walls and high domed ceiling. The basement, however, has been heavily reconfigured. The central space which originally housed only the furnace and a small washroom has been further subdivided to accommodate a kitchenette, an additional washroom and a mechanical room. One basement window has been reclaimed for mechanical use having been retrofitted for ventilation. The eastern work room has been expanded with the removal of a wall separating that space from the coal bin. The configuration of the western work room has changed with its conversion to an exhibition space. (See Section 2.7 Uses). The tall windows in this room have been covered over. Figure 17 shows that the room is now very dark; the windows are still visible from the exterior but are no longer operable from the interior.



Figure 16. Observatory dome. Retrieved from <http://www.flickr.com/photos/76533967@N05/>



Figure 17. Basement exhibition space. Retrieved from <http://www.flickr.com/photos/76533967@N05/>

Figure 18. Section through the Observatory. Retrieved from Facilities Management Division Asset Record System, File O-3-T.

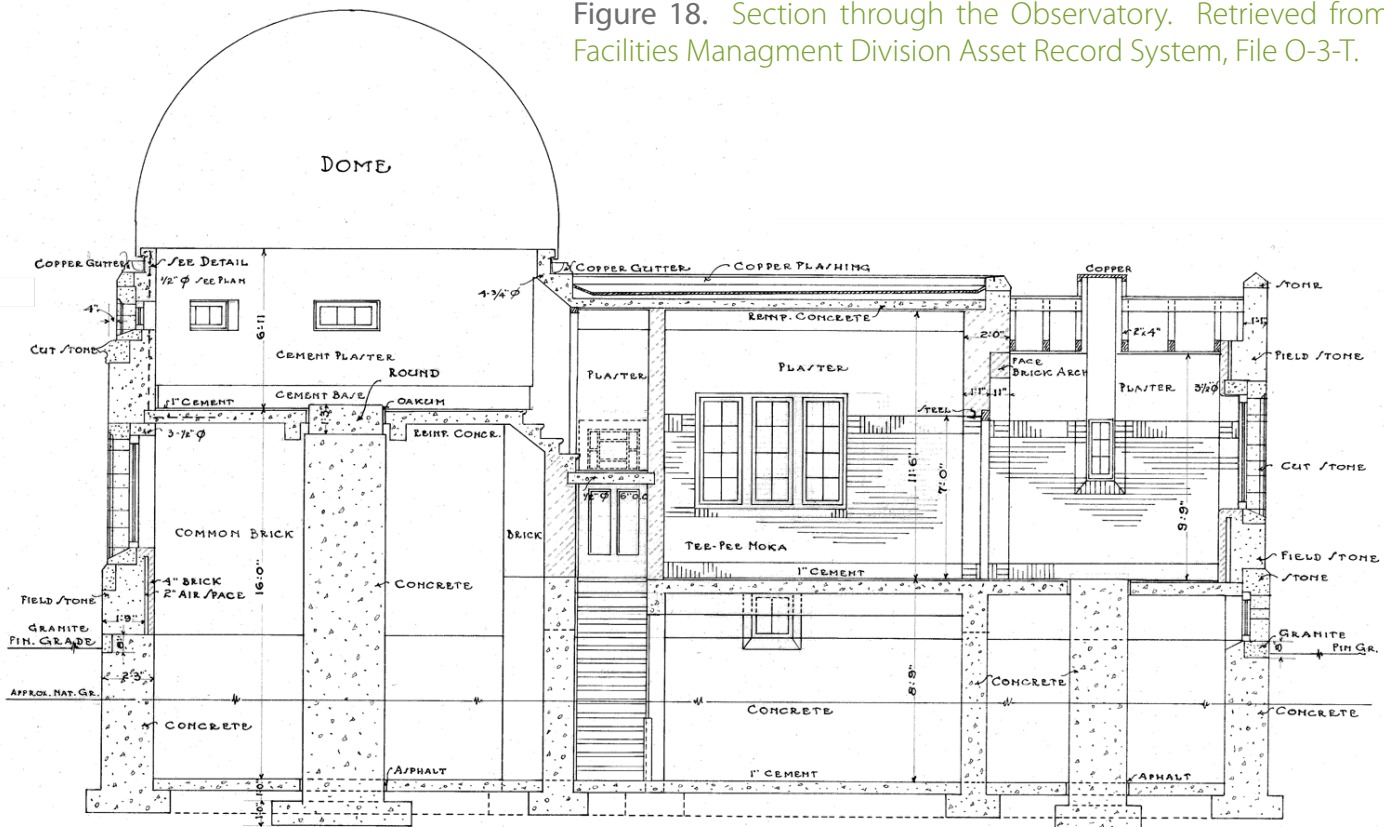

Figure 19. Retractable roof.

2.6 Systems

The Observatory's structure is composed of load bearing concrete and stone walls on concrete strip foundations. A unique structural feature of the building is the inclusion of two very large concrete columns. The columns are located under the two telescopes in the building to prevent any vibration or movement that might hinder the functioning of the instruments. These large character-defining elements are visible in the section shown in Figure 18.

The Duncan Telescope is still in its original location. The instrument was ordered from T. Cooke & Sons. In the 1970's it saw major refurbishment, including the replacement of its 7" lens with a 6" model. The Duncan Telescope is a character-defining element.

The large telescope gains access to the night sky by means of a motor-operated sliding door in the dome (Figure 21). The original dome had a hand operated door. The original wire and papier-mache dome was replaced by an aluminum dome in April, 1976 (University of Saskatchewan Archives. U of S Observatory, Kennedy Additional - Box 7). An astronomy enthusiast near Saskatoon reclaimed the original dome and it now serves as the dome on an amateur observatory. The current dome was manufactured by the Ash Manufacturing Co. in Plainsfield, Illinois. The form and functionality of the dome is a character-defining element.

Another character-defining system found in the building exists in the transit room on the ground floor. There the roof can be opened to reveal the sky to the north and south. Copper-clad portions of the roof can be raised by a hand crank. The mechanism (Figures 19 & 20) is intact on the north side of the room. The mechanism on the south side appears to have been disabled.

When the Observatory was built, its location was so removed from the other campus buildings that the cost to run a service tunnel to provide heat, light and power to the small building proved prohibitive. It was originally constructed with a coal bin and coal furnace to provide warmth. Living quarters were provided for in the building in order that the furnace could be kept stoked. The coal burning system was removed when gas was provided to the building.

2.7 Use(s)

The building has been used for astronomical study since its construction. The dome has always housed a telescope and the classroom maintains its original function. Originally the basement housed a furnace room, two work rooms, one washroom and a coal bin. Physics students, sometimes in pairs, lived in the basement and kept the coal furnace stoked in return for the use of the quarters. The work room has been remodeled to become a museum and exhibition space (Figure 17). When a natural gas line for heating was run to the Observatory, the coal bin was removed in order to create a larger work room. A kitchenette and an additional washroom have been added. (See Section 2.5, Spatial Configuration).

The Duncan Telescope saw gradual mechanical deterioration and slowly fell into disuse by 1964. In that year, amateur astronomy groups in Saskatoon renewed the use of the telescope and assisted in opening the Observatory for public viewing. By the 1970's the Observatory was used almost exclusively for public outreach and free tours were run every Saturday night. Professor W.H. White opened the Observatory to the public weekly for a period of 18 years.



Figure 20. Crank and lever system.



Figure 21. The slot door in the open position. The Duncan telescope is in the foreground. Retrieved from <http://www.flickr.com/photos/76533967@N05/>



Figure 22. Sextant, ca. 1820 originating in England.

2.8 Cultural & Chronological Associations

Along with Field Husbandry (currently [Archaeology](#)), the Observatory was one of the last buildings erected in the first phase of construction at the University of Saskatchewan. The Great Depression put a temporary stop to any large projects after these buildings. Another important aspect of the heritage of this building is that the telescope it was built to house was funded by private donations.

3. Associated Objects

The basement exhibition space holds two objects of particular value to the astronomical community. A sextant originating in England circa 1820 was donated to the Observatory in 1951 by professor W.H. White (Figure 22). A Gregorian style reflector telescope made in 1727 by Francis Watkins of Charing Cross London is another instrument found in the space. The telescope features a mirror made of speculum, an alloy consisting of two parts copper and one part tin. In 1944-1945 a sundial (Figure 23) was designed and donated to the building by Professor W.H. White (University of Saskatchewan Archives, RG 2001.2, General Correspondence, White). It read:

I Am A Shadow
So Art Thou
I Tell Time
Dost Thou
?

This sundial was originally mounted on the south side of the building. The bottom portion of the sundial provides the 'equation of time' which, when used with the position of the shadow on the dial provides the correct time. After being restored several times it was removed and is currently being stored in the Physics Building. Photographic records place its removal between the years 1991 and 1996. The brackets that formerly held it are still in place.

A tablet in the telescope room commemorates those who donated funds towards the telescope. An initial donation of \$500.00 by W.H. Duncan was the impetus for a fundraising campaign by the Saskatoon Board of Trade. The same is indicated by the wording on the plaque. (See Figure 24). The initial donor's surname provided the title for the 'Duncan Telescope.'

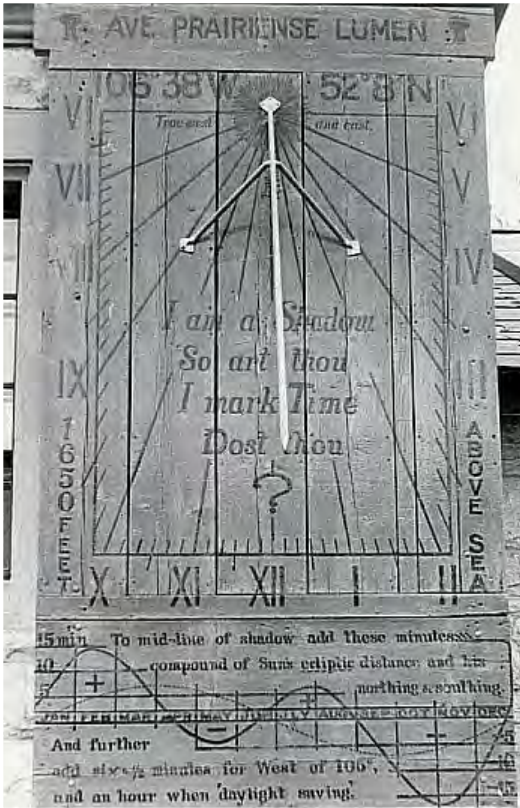

Figure 23. The sundial that formerly adorned the Observatory, ca. 1950. Photo A-914. Retrieved from http://scaa.sk.ca/gallery/uofs_buildings/



Figure 24. Plaque commemorating those who helped to purchase the telescope.

4. Supporting Documents

Facilities Management Division (2011). Asset Resource Database [Data File]. Retrieved from \\usask\fmddfs\files\iis\IIS_Public\ARS

Lemhukl, P. (Producer). (2013, September 3), *U of S Campus Observatory: A Brief History*. Saskatoon, SK: Youtube. Retrieved from <http://www.youtube.com/watch?v=oD-7FbjjUoo>

Mysyk, W.K. & Kulyk, C.L. (2006). *Saskatoon's Stone*. Saskatoon: Houghton Boston Printers & Lithographers Ltd.

University of Saskatchewan Archives. (Retrieved 2012) *Observatory*. Retrieved from <http://www.usask.ca/archives/databases.php>

University of Saskatchewan Archives. Buildings and Grounds Department 2015, 11, Observatory.

University of Saskatchewan Archives, J.E. Kennedy fonds.

University of Saskatchewan Archives, RG 2001.2, General Correspondence, White

University of Saskatchewan Archives. U of S Observatory, Kennedy Additional - Box 7.

U of S Observatory. (Retrieved 2012) *U of S Observatory*. Retrieved from <http://physics.usask.ca/observatory/>



5. Summary of Character - Defining Elements



Materials

- greystone walls
- Indiana limestone trim
- granite steps
- brass door & window hardware, grilles
- copper roof
- steel window frames
- oak doors and surrounds
- slate chalkboard
- brick wainscoting

Form

- round tower
- dome
- human scale

Style

- arched door opening
- gothic arched transom
- quoining
- dormer roof
- parapet
- oak doors
- wooden rafter ends

Location

- still located on original site
- visibility of night sky
- orientation relative to cardinal directions

Spatial Configuration

- round telescope room
- classroom

Systems

- retractable roof system
- slot door in dome
- concrete columns under telescope & transit
- Duncan Telescope

Uses

- astronomical observation and research
- education
- tours and public outreach
- museum

Cultural & Chronological Associations

- one of the last buildings erected before WWII
- telescope funded by private donations

027

Poultry Science Building



027

Poultry Science Building

Alternate Names

N/A

Architect(s)

David Brown and Hugh Vallance, Brown and Vallance Architects, Montreal

Builders

Unknown

Construction Dates

Disputed: 1915, 1918, 1919

Recognition

University of Saskatchewan 'B' Listed

1. Statement of Significance

With construction likely completed in 1918, the Poultry Science Building is one of the earliest University of Saskatchewan buildings. It was one of the first five buildings tendered, the others being the [MacKinnon Building](#), [Saskatchewan Hall](#), the Steam Plant and the [Stone Barn](#). By virtue of its age and distinctive architectural style, the Poultry Science Building is a heritage asset. It also played an important role in carrying out the mandate of the University of Saskatchewan as an agricultural college.

The Poultry Science Building has the form and architectural style of a barn, but it was always actually configured as an educational building and constructed using standard residential wood-frame construction methods. This two storey building consists of a basement, main and first floor. Its location near other University of Saskatchewan barns reinforces its association with the College of Agriculture. Its form, in the shape of a barn, is a distinguishing character-defining element. The building's form has been altered with the demolition of an east wing and the subsequent addition of a west wing in 1959. However, these amendments to the form have left the style of the building intact. The later addition of the west wing is beyond the scope of this report.



Figure 1. Cedar shingles and exposed wooden rafter ends, both painted.



Figure 2. A set of wood-framed storm windows.

2. Character - Defining Elements

2.1 Materials

Painted cedar shingles define the exterior material character of the Poultry Science Building (Figure 1). Painted wooden sash windows are another important feature, shown in Figure 2. The roof was likely originally clad in cedar shingles, but currently has asphalt shingles.

Douglas Fir is a prominent material in this building's interior, used as flooring, ceilings and wall paneling. Ceilings and walls appear to have been originally finished with a clear varnish, but have subsequently been painted. Figure 3 shows the condition of the painted Douglas Fir paneling. Doors, also in Douglas Fir, have been painted as well. The high quality of the original fir material is evident in an upstairs closet which has remained unpainted and is shown in Figure 4. Tongue and groove Douglas Fir floorboards have been covered with vinyl composition tile. The building's interior doors feature beveled glass, another character-defining element. Some of these glass panels have been painted or covered (Figure 5). An original chalkboard made of slate is located in the classroom (Figure 6).

A single staircase, featuring painted wooden balustrades and treads, offers access to the basement and the first floor. The stair treads have been covered in vinyl composite tile. The wooden balustrade has been painted (Figure 8).



Figure 7. The Poultry Science Building in 1959, before the removal of the eastern wing. Photo retrieved from the 1959 Book of Appraisals, University of Saskatchewan Archives.



Figure 3. Painted Douglas Fir interior panelling.



Figure 4. Unpainted Douglas Fir interior panelling.



Figure 5. Bevelled glass.

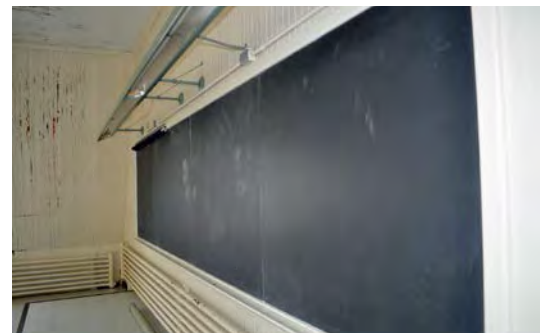

Figure 6. Slate chalkboard.



Figure 8. Painted wooden balustrade.

2.2 Form & Style

The barn-shaped form of the building, particularly its gambrel roof, is a character-defining element. The gambrel roof is characterized by a shallow-pitched top section and a more steeply-pitched bottom section, with overhanging eaves. This element is illustrated in Figure 9.

Gambrel dormers and decorative truss ends are other exterior elements defining the character of the building (Figures 9 & 10). The gambrel dormers are embellished with wooden roundels to accentuate the arched shape of the windows. (Figures 9 & 11) The building's doors are characteristic of the 'arts and crafts' style. The use of shingles as a cladding material also contributes to the barn-like appearance of the building; the university's prominent [Stone Barn](#) is clad in the same material.

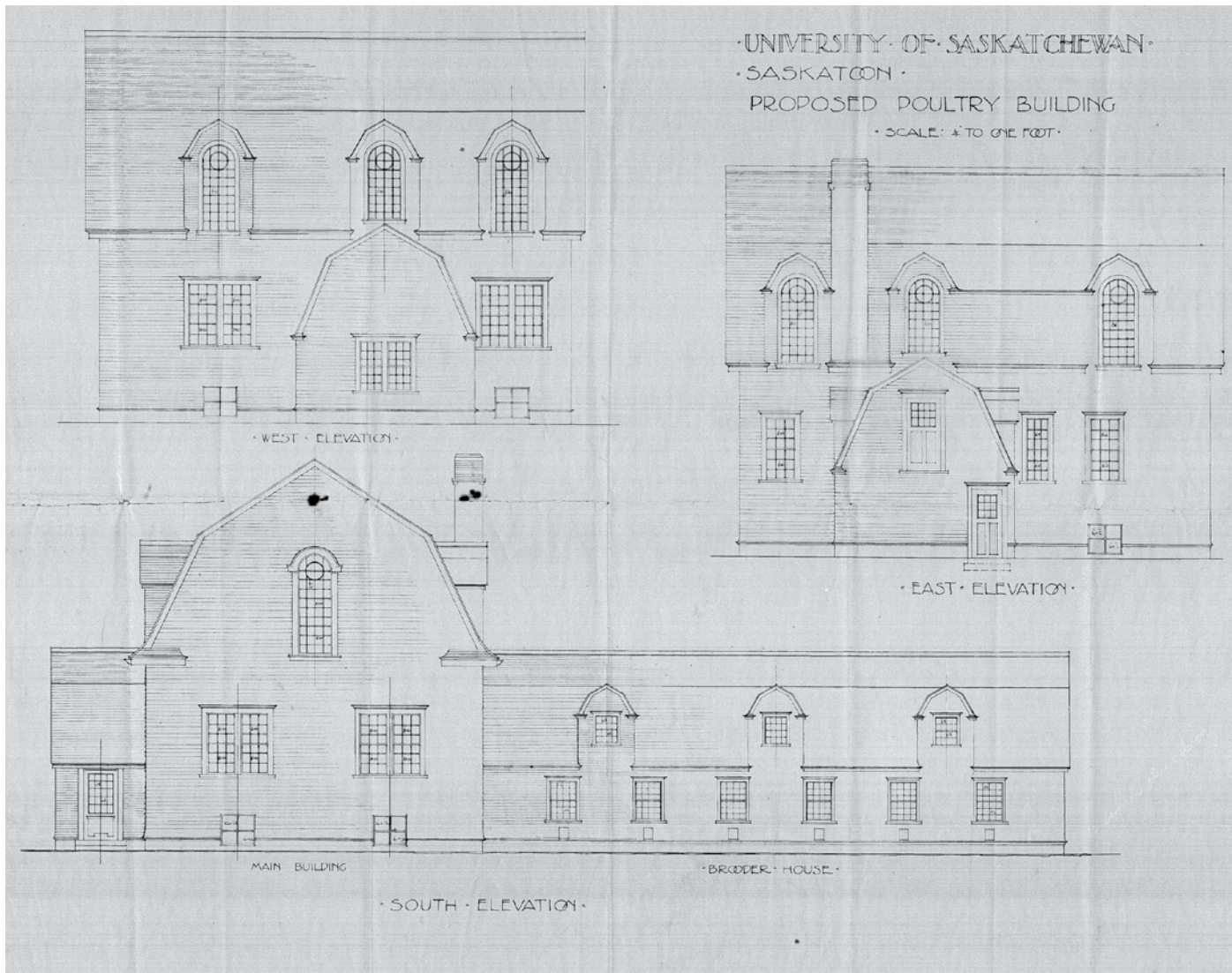

Figure 9. Elevations of the Poultry Science Building showing gambrel roof elements.. Retrieved from Asset Record System, File PH-2-T.



Figure 12. The Poultry Science Building as viewed from the south, ca. 1916. Photo A-681, retrieved from University of Saskatchewan Archives.

Originally, the building featured an elongated ‘brooder house’ (shown in Figure 12) on its east side. In 1959, the small vestibule that protruded from the west face of the building was extended. For a time the building existed with both an east and a west wing before the east wing was demolished in 2000. The form of the new west wing is very similar to that of the former east wing. Figures 12 and 13 show the original form of the building and the current form of the building, respectively. Note the change in the location of the ‘brooder house’ wing. Despite the removal of one wing, and the addition of a new one, the character of the building has been maintained with a good degree of commemorative integrity.

2.3 Location

The Poultry Science Building is not found on the 1909 Campus Plan, but its location is original. Figure 14 shows this location, adjacent to Rutherford Rink and the Curling Rink. It is situated in proximity to the other university barns.

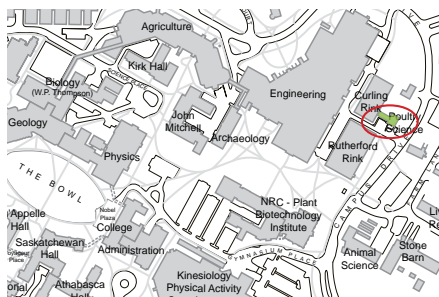

Figure 14. The location of the Poultry Science Building is indicated in green on this contemporary campus map.



Figure 10. L to R: gambrel dormer, decorative rafter ends.



Figure 11. Gambrel dormer windows with wooden roundels, ca. 1918. Photo A-3834, retrieved from University of Saskatchewan Archives.



Figure 13. The Poultry Science Building in its current form, as viewed from the south.

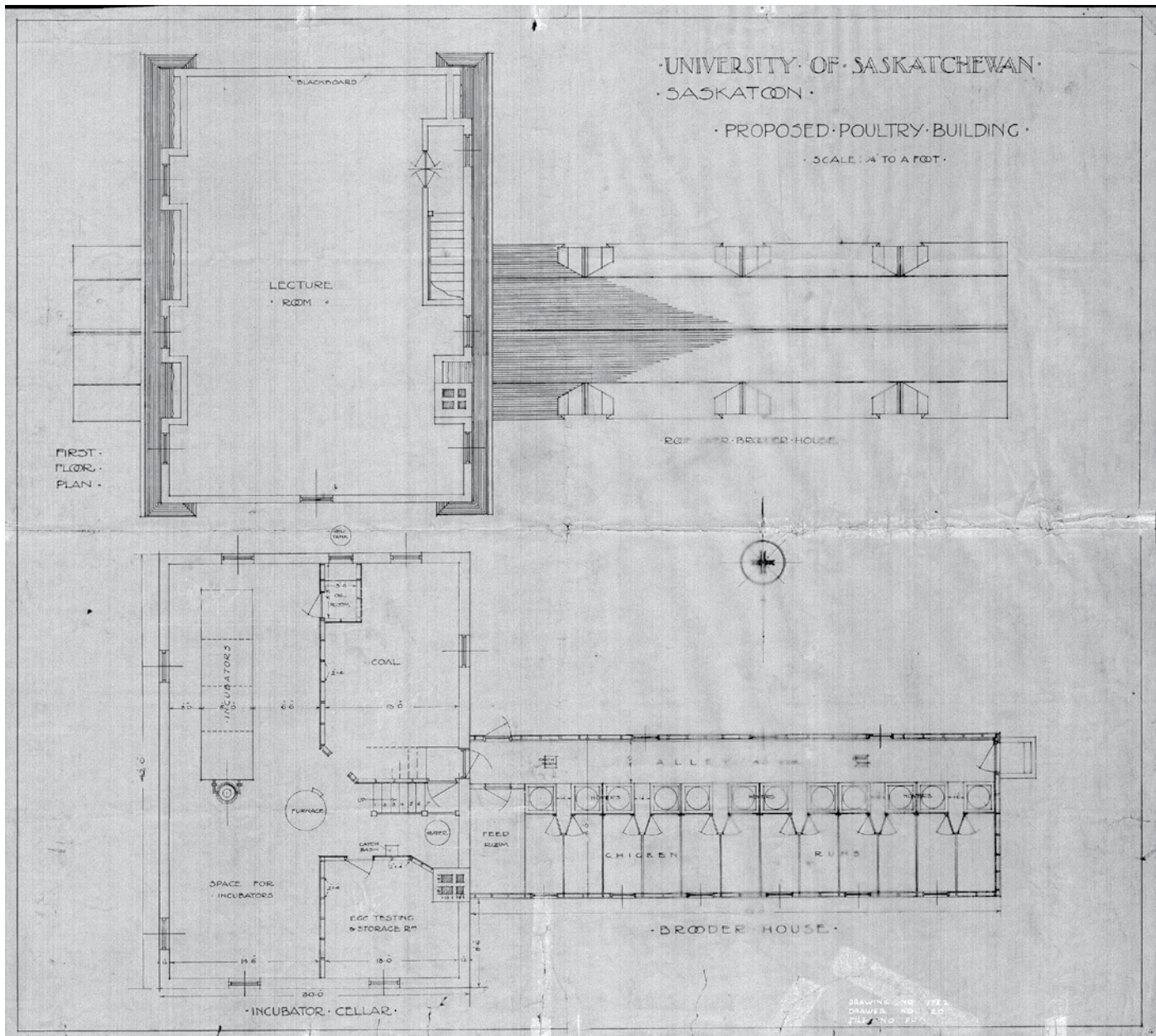

Figure 15. The basement and first floor plan of the Poultry Science Building as it was originally configured. Retrieved from Asset Record System, File PH-3-T.

2.4 Spatial Configuration



Figure 16. The first floor lecture hall.

The remaining original portion of the Poultry Science Building consists of a two-storey structure, which is entered through a vestibule (now extended to become a wing). The main floor of the original space is raised up from grade level and is accessed from a short set of wide stairs. The raised main floor is subdivided into a number of individual rooms, as shown in Figure 15. Principal spaces included a poultry judging room, a library and records room, an office for ‘Professor Baker,’ an attendant’s room and lavatories for men and women. A cloak room was also provided for the women. The building’s single staircase offers access to the basement and the first floor loft space. Figure 17 illustrates the relative height differences between floors.

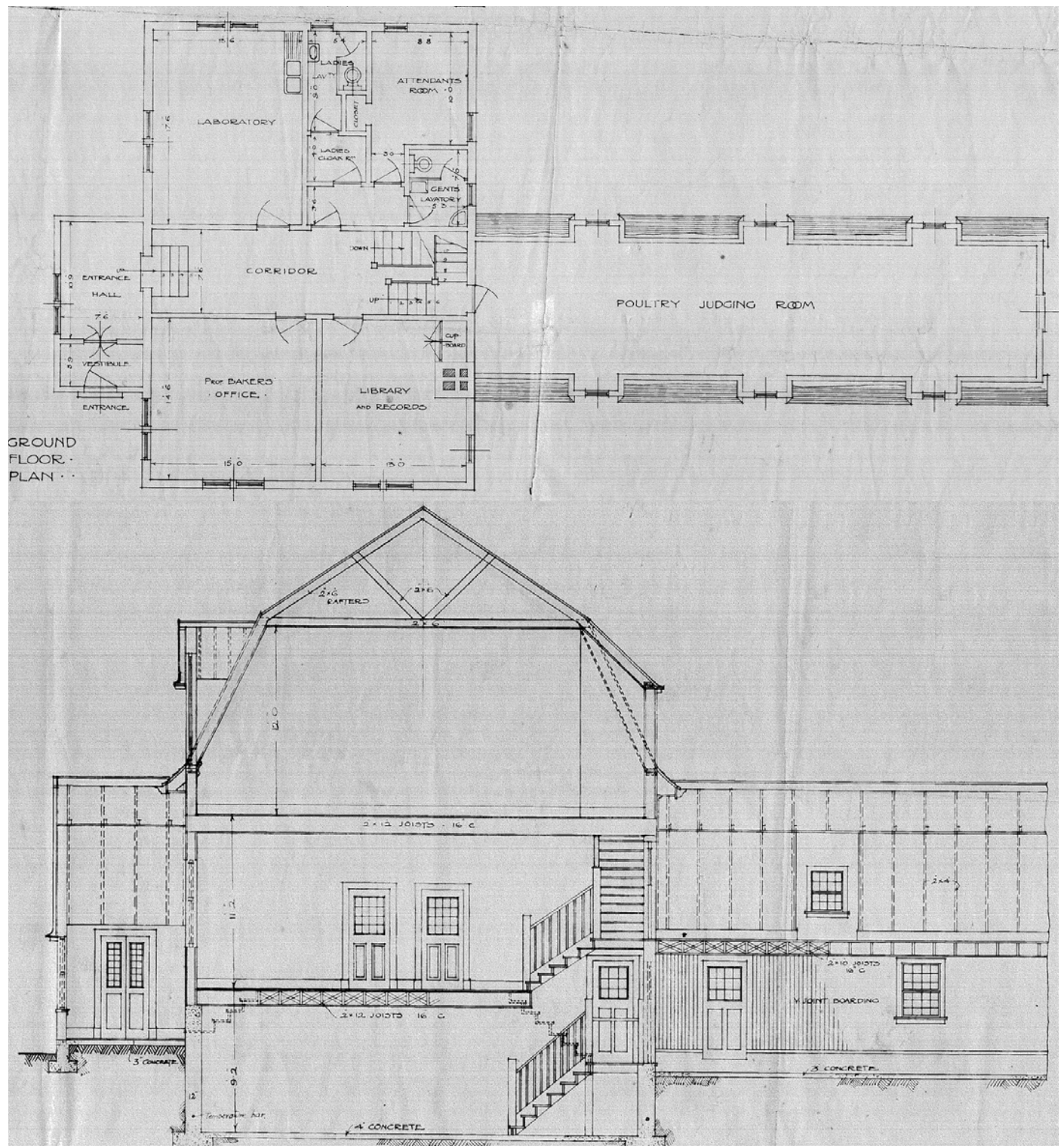

Figure 17. Original ground floor plan and section through the Poultry Science Building. The area labelled 'Poultry Judging Room' no longer exists. The west wing has been extended and the east wing has been removed. Retrieved from Asset Record System, File PH-1-T.



Figure 18. The lecture hall. Photo A-2614, retrieved from http://scaa.sk.ca/gallery/uofs_buildings/

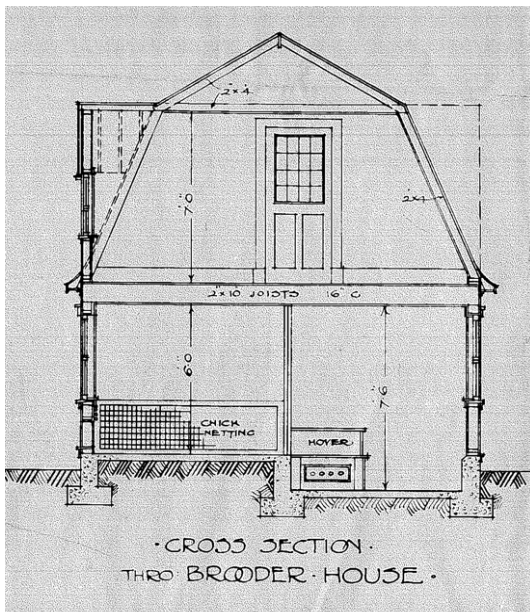

Figure 19. A section through the Poultry Science Building's original brooder house. Retrieved from Facilities Management Division Asset Record System, File PH-1-T.

As Figure 17 illustrates, the second floor consists of a single large open space, accessed from a stairwell running up the east side of the building. Tall windows on three sides provide ample natural light. A chalkboard is mounted on the north wall. A small closet exists on the east side of the room, above the stairs. A 12' ceiling height gives the space a light and airy character. The tall gambrel dormer windows create arched niches in the walls of the space. The natural light, arched window niches, open floor plan and the height of the space are all character-defining elements.

The basement is subdivided into three rooms, including a small service room in the southeast corner. It is lower than the other two floors, with a ceiling height of 9'-2" (Figure 15).

The former brooder house consisted of two floors, each of which had an entrance. These entrances are still visible on the interior of the building's east wall. Both of them are now boarded up. Figure 19 provides a section through the original brooder house.

2.5 Systems

Although its gambrel roof gives this building a distinctive barn-like appearance, this building's structure is more typical of the residential construction methods of the time. Walls consist of 2 x 4" Douglas fir studs, supported on concrete basement wall foundations and footings. Floors consist of 2 x 12" fir joists. The top section of the gambrel roof is formed by a series of fir trusses, which sit on rafters forming the lower portion of the roof.

2.6 Use(s)

The Poultry Science Building is unusual in that it was built to accommodate both live animals and people. The main floor of the two-storey central section of the building housed an office, library and records room, laboratory, washrooms and an attendants' room. As illustrated in Figure 18, the first floor was used as a lecture theatre. The basement was designated for feed storage, egg testing, and egg incubation. A small classroom was located there as well.

The east wing, now demolished, was both a brooder house for poultry and a dormitory for students. Its basement contained individual rooms for chickens, while the main floor was devoted to poultry judging. The second floor was a student dormitory, such that the students lived above the chickens!

The building no longer houses the Poultry Science Department, and is now unused.

2.7 Cultural & Chronological Associations

Although no longer in use, the Poultry Science Building is still associated with its former role as the home of the Poultry Science Department. In its form, style, use and location, it is associated with agricultural education at the University of Saskatchewan.

A product of the Poultry Sciences breeding program, a pullet by the name of 'Lady Victorine', set a world record in 1927. The bird laid 358 eggs in 365 days to win the prize.



Figure 20. Poultry judging. Retrieved from Thomas, L.H., (1959), *The University of Saskatchewan 1909-1959*.



3. Associated Objects

N/A

4. Supporting Documents

Facilities Management Division (2011). Asset Record System [Data File]. Retrieved from \\usask\fmddfs\files\iis\IIS_Public\ARS.

Kerr, D. Building the University of Saskatchewan, 1907-1930. *Prairie Forum* 5 (1980).

University of Saskatchewan Archives. (Retrieved 2011). *Campus Buildings: Poultry Science Building*. Retrieved from http://scaa.sk.ca/gallery/uofs_buildings/.

Tastad, M. (April 23, 1999). May the Home of Lady Victorine be Preserved for its Heritage Status and Beauty. *On Campus News*, 6(15). Retrieved from http://news.usask.ca/archived_ocn/Apr23-99/opinion.html

Thomas, L.H. (1959). *The University of Saskatchewan 1909-1959*. University of Saskatchewan: Saskatoon.

5. Summary of Character - Defining Elements

Materials	<ul style="list-style-type: none">▪ painted cedar shingles▪ douglas fir flooring, ceiling & wall paneling▪ beveled glass▪ wood-framed sash windows▪ bronze or brass hardware
Form & Style	<ul style="list-style-type: none">▪ barn shape▪ gambrel roof▪ gambrel dormers▪ arches (gambrel and rounded)▪ decorative rafter ends▪ 'arts and crafts' style doors
Location	<ul style="list-style-type: none">▪ original location
Spatial Configuration	<ul style="list-style-type: none">▪ open plan first floor▪ tall windows on first floor▪ gambrel niches
Uses	<ul style="list-style-type: none">▪ poultry education and research (laboratory, library and records room, office, lecture theatre)▪ poultry breeding (brooder house, incubating)▪ poultry judging▪ student residence
Cultural & Chronological Associations	<ul style="list-style-type: none">▪ agricultural education▪ Poultry Science Department



031

Kirk Hall

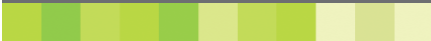

031

Kirk Hall

Alternate Names

School of Agriculture

Architect(s)

**Frank J. Martin, Portnall and Stock Associated Architects,
Regina and Saskatoon**

Builders

Department of Public Works

Construction Dates

1947-1949

Recognition

N/A



Figure 1. Indiana limestone, grey Canadian granite, yellow brick.



Figure 2. Single glazed steel casement windows.

1. Statement of Significance

Kirk Hall is one of two buildings designed by Frank J. Martin of Portnall and Stock Associate Architects, and built at the same time, between 1947 and 1949. Kirk Hall and the [John Mitchell Building](#) share many similarities in materials, form and detail. Originally called the School of Agriculture Building, Kirk Hall was renamed in 1962 after Lawrence Eldrid Kirk, who served as Dean of Agriculture from 1937 to 1947. The building cost \$600,000, a portion of which was provided for by the federal government on the understanding that the building be used only for the purposes of agricultural education for a period of ten years.

Kirk Hall is designed in a simplified Collegiate Gothic style characteristic of the architecture of the University of Saskatchewan campus in the immediate post-war period. However, it is distinguished by a departure from earlier buildings in its materials and form. It has some heritage significance for this reason and for the commemorative integrity of its material, form and spatial configuration.



Figure 3. Kirk Hall. Photo A-483, retrieved from University of Saskatchewan Archives.

Kirk Hall is notable as the first academic building at the U of S devoted entirely to the College of Agriculture. At one time it also served as a student residence, housing all the students of the College.

Note: Kirk Hall is configured with floors numbered Basement, Ground Floor, First Floor, Second Floor and Third Floor. This report follows the same convention.

2. Character - Defining Elements

2.1 Materials

The exterior of Kirk Hall is characterized by yellow brick with Indiana limestone trim and a base of grey granite (Figure 1). Yellow brick is a character-defining material, the intention of which was to denote agricultural buildings. Yellow brick was also used for the Virus Laboratory (now demolished) and the Soils and Dairy Building (now known as the [John Mitchell Building](#)). Limestone and granite are materials used on many buildings at the University of Saskatchewan. As Figure 2 illustrates, windows are single-glazed with green painted rolled steel frames. These windows and their materials also constitute character-defining elements. Exterior doors are oak with brass hardware. The main entrance doors also feature oak-framed side lites (Figure 4) The oak, brass and glazing of the doors are character-defining elements.



Figure 4. L to R: Oak doors with transom glazing, Indiana limestone, yellow brick.



Figure 5. Terrazzo flooring.



Figure 6. Terrazzo window sill and purple, red and black glazed ceramic tile.



Figure 7. The brick mantle of the basement fireplace now inside a lab.



Figure 8. Blue and white glazed ceramic tile.



Figure 9. Red quarry tile hearth surrounded by white glazed tile on terrazzo flooring.

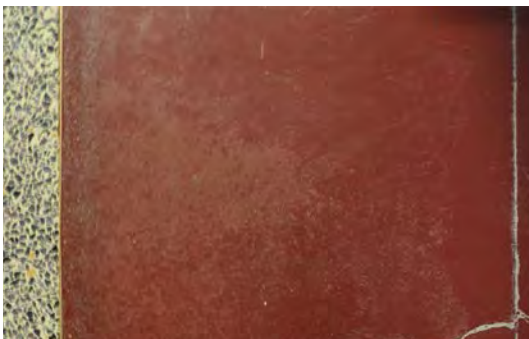

Figure 10. Painted concrete flooring.

The interior of the building is defined by materials different from those used previously at the university. The floors throughout the building are finished in terrazzo as are the stair treads and landings of all three staircases (Figure 5). The condition of the terrazzo varies: in the basement, it has been repaired in several places with terrazzo or polished concrete. The window sills are also terrazzo and generally exist in good commemorative condition. Terrazzo is a character-defining material.

The interior of Kirk Hall is characterized by the use of brick and glazed ceramic tile for walls (Figure 6). In the west end of the basement, walls are faced in yellow brick in both the corridor and interior of the rooms. The brick generally exists in good commemorative condition. A brick fireplace surround also remains in fair commemorative condition (Figure 7). All floor levels feature the use of glazed tile as a wall surface. For example, the staircase shown in Figure 8 features white glazed tile wainscoting with a blue glazed tile border on all floors. The same is found in washrooms and areas formerly used as washrooms. The tiles generally exist in excellent condition. The hearth of the first floor fireplace features character-defining red quarry tile in excellent condition (Figure 9). Most of the hallways feature a painted border on the floor, as seen in Figure 10.

Various species of wood are used in the building, including oak, fir, maple, pine and birch. This variation represents a departure from the buildings designed by architects Brown and Vallance, who predominantly specified oak. The maple used for the doors in Kirk Hall is a character-defining element. The doors exist in varying states of preservation, with most of the residence room doors having been replaced. The double doors to the auditorium, recreation rooms and cafeteria have been maintained. Originally, doors leading into the central stair were oak and glass; however, these have been replaced by steel doors. In most instances, these replacement doors still feature the original brass hardware. Figure 11 shows a set of doors in the original maple with brass hardware.

The lecture room features a platform and wainscoting in maple. The platform may have been replaced, since the original drawings specified fir with pine risers and maple nosings and treads. The top of the platform is now finished in vinyl composition tile, which is not original to the building. This room also features an original slate and oak chalkboard. However, as shown in Figure 12, another chalkboard has been installed over top of it. The original maple doors and wainscoting of the lecture room are character-defining elements.

Door and window hardware is generally in an excellent state of commemorative integrity. The windows feature brass latches that still match throughout the building. The windows are operated

with steel cranks that have also all been retained. A character-defining feature of the windows is the use of a large single pane of glass on the interior rather than several separate lites, representing a stylistic change from previous buildings (Figure 13). The brass door hardware has generally been maintained.

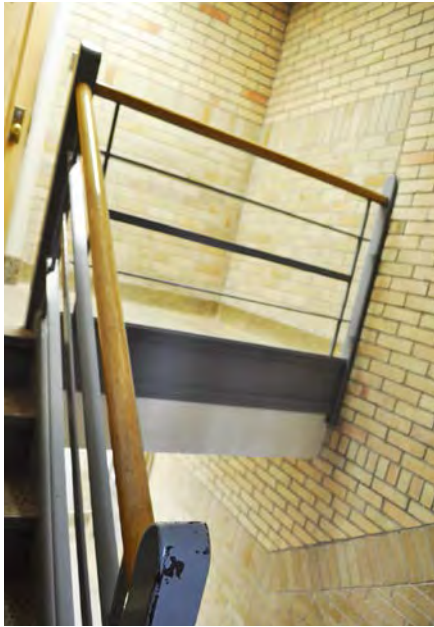

Figure 14. The north staircase: steel stringers, iron balustrade and birch banister. A yellow brick wall is in the background.

The staircases are made with steel stringers, treads and balustrades. The main stair features its original ‘alumilite’ handrail. Other handrails are birch. These steel staircases with their wooden and aluminum banisters are character-defining materials.



Figure 11. Maple doors with glazed panels and brass hardware.



Figure 12. Slate chalkboard beneath a newer chalkboard that has been added over top.

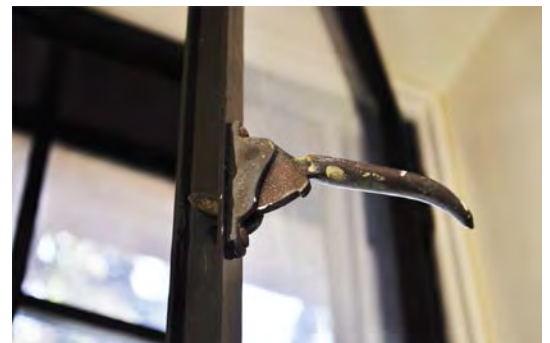

Figure 13. Brass window fixtures attached to a painted steel casement.

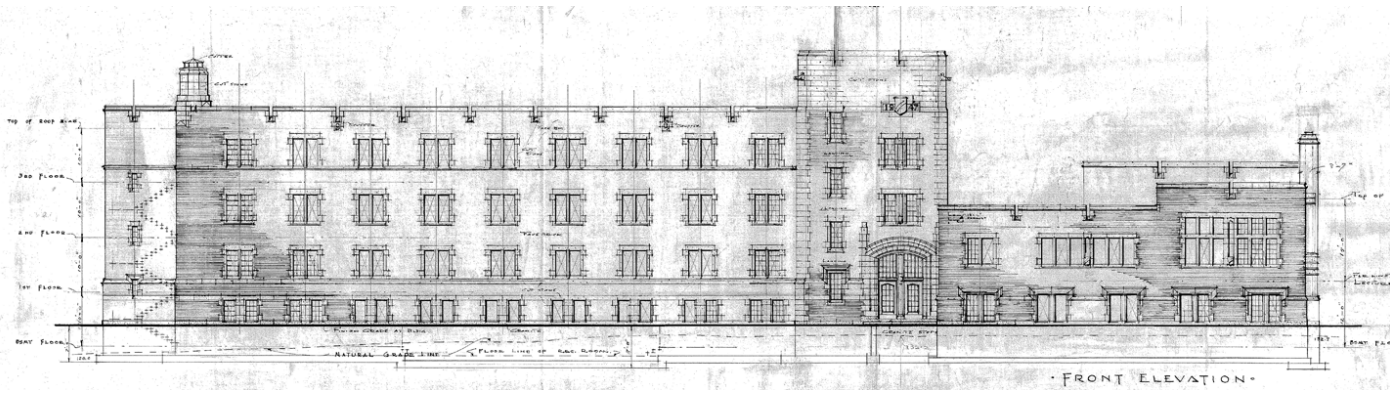

Figure 15. Front elevation of Kirk Hall showing assymetry of design and limited use of gothic ornamentation. Retrieved from Facilities Managment Division Asset Record System, File KH-48-T.

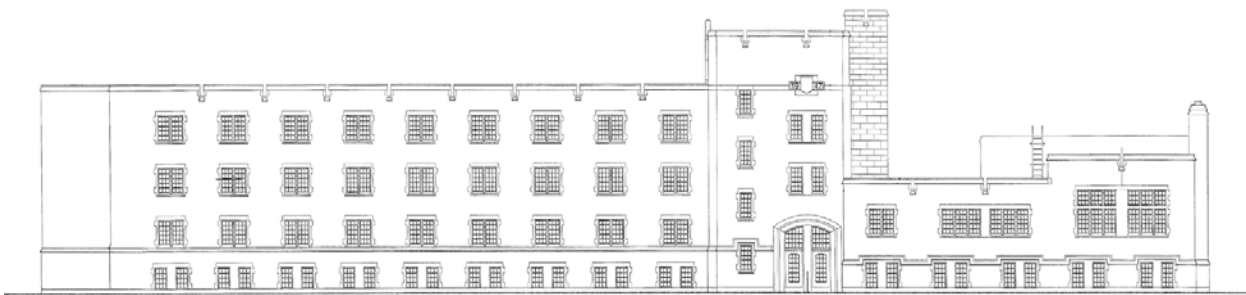

Figure 16. Front elevation of Kirk Hall showing assymetry of design and the addition of an elevator shaft. Retrieved from Facilities Managment Division Asset Record System, File 031-221-T.



Figure 17. The form of Kirk Hall. Photo A-472, retrieved from University of Saskatchewan Archives.

2.2 Form & Style

Kirk Hall represents a shift from the style of the buildings preceding it on campus. Earlier buildings had for the most part been symmetrical or had been planned to be symmetrical once completed. The intended assymetry of Kirk Hall represents one of the first tentative forays into the Modern style, and is a character-defining formal element (Figure 15).

The orthogonal form of the building is of interest for the same reason. Right angles and rectilinear forms characterize Kirk Hall both in plan and elevation. The front entrance and central staircase are contained within a tower protruding from the primary volume (Figure 15). Kirk Hall features flat roofs and cubic volumes. (An elevator shaft added in 2009 is visible on the elevation shown in Figure 16.)

Exterior detailing is notably reduced and simplified compared to earlier campus buildings. Windows are rectangular, not arched, and stone tablets are left square and blank. The stone shield on the tower is deliberately positioned off-centre. This simplified detailing is applied to both traditional materials, such as brick and stone, and modern interior finishes such as terrazzo and



Figure 22. Architrave and doors with arched transom.



Figure 23. Gothic arch shape on newel post, arched glazing in doors.

exposed concrete. However, despite a subtle shift to the modern idiom, the building contains many other references to the older Collegiate Gothic architectural style. Its limestone quoins, stone string courses (Figure 18) and archer slot windows (Figure 19) are all characteristic examples. Its stone drainage spouts and crenellated parapet are also character-defining elements of the Collegiate Gothic style (Figure 20). The carved stone shields and blank tablets are further gothic character-defining elements (Figure 18, 20 & 21). The main entrance is located in a shallow architrave formed of carved stone. The doors themselves have an arched transom. Figure 22 shows the gothic elements of the entrance. On the interior, the posts of the balustrade take the form of pointed arches (Figure 22). The doors leading to the double height spaces on the first floor have arched windows set into them. All of these gothic references - the tower, architrave and arch motifs - have heritage value and are character-defining.



Figure 18. String courses and stone blanks.



Figure 19. Archer slot style window.



Figure 20. Carved stone shield, parapet and stone drainage spout.



Figure 21. Carved stone shield motif.

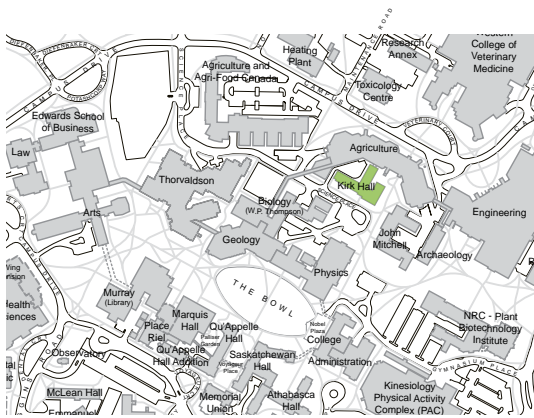

Figure 24. The location of Kirk Hall is indicated in green on this contemporary campus map.

2.3 Location

Kirk Hall was the first building constructed in what was to become an agricultural precinct on campus. Located near the Field Husbandry building (now the [Archaeology Building](#)), Kirk Hall precipitated the placement of later agricultural buildings in the area such as the Virus Laboratory, now demolished, the Soils and Dairy Building, now known as the [John Mitchell Building](#) and much later, the College of Agriculture Building.

2.4 Spatial Configuration

The interior spatial configuration of Kirk Hall is characterized by its double-loaded corridors, with mostly small rooms arrayed on either side. Many of the rooms now used as offices were originally dormitory rooms, and each is provided with its own window. This configuration defines the character of the building as a former residence hall. In a few cases walls between rooms have been removed to create larger rooms. Figure 25 shows an example of the double-loaded corridors.

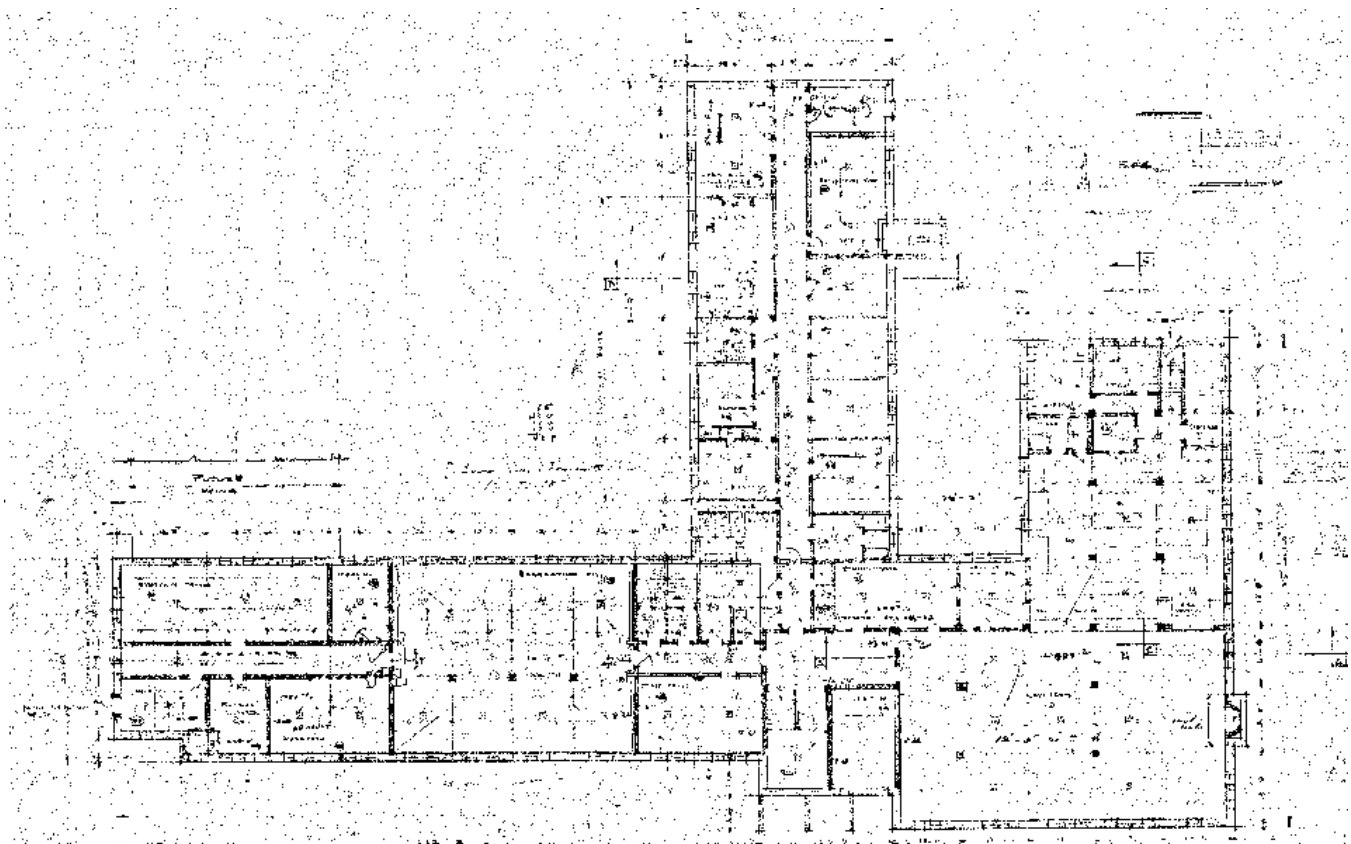

Figure 25. The original configuration of the basement level. Retrieved from Facilities Management Division Asset Record System, File KH-5-T.

The basement has seen the greatest reconfiguration of its spaces. As shown in Figure 27, the eastern end of the building was originally open in plan, housing a cafeteria and a kitchen. Figure 27 illustrates this original arrangement. This section of the plan has been reconfigured into a more compartmentalised floor plan of separate offices and laboratories as shown in Figure 28. Remnants of a fireplace and hearth are a reminder of the cafeteria space. See Section 2.1 Materials, Figure 7. An elevator shaft has also been added causing reconfiguration on all floors.

The ground floor has character-defining spaces in its lecture room and the former common room (now used as a classroom). Both spaces are double-height volumes and feature tall windows. The heights of these spaces and their windows are character-defining elements of the building's spatial configuration. Figure 28 shows the former common room, which has retained its original configuration. The fireplace in the room still exists but has been sealed. In the lecture hall, an elevated projector room was originally an open 'orchestra balcony' with a wooden banister. (Figure 29 illustrates the lecture room).



Figure 26. The original configuration of the cafeteria space in the basement. Photo A-484 retrieved from University of Saskatchewan Archives.

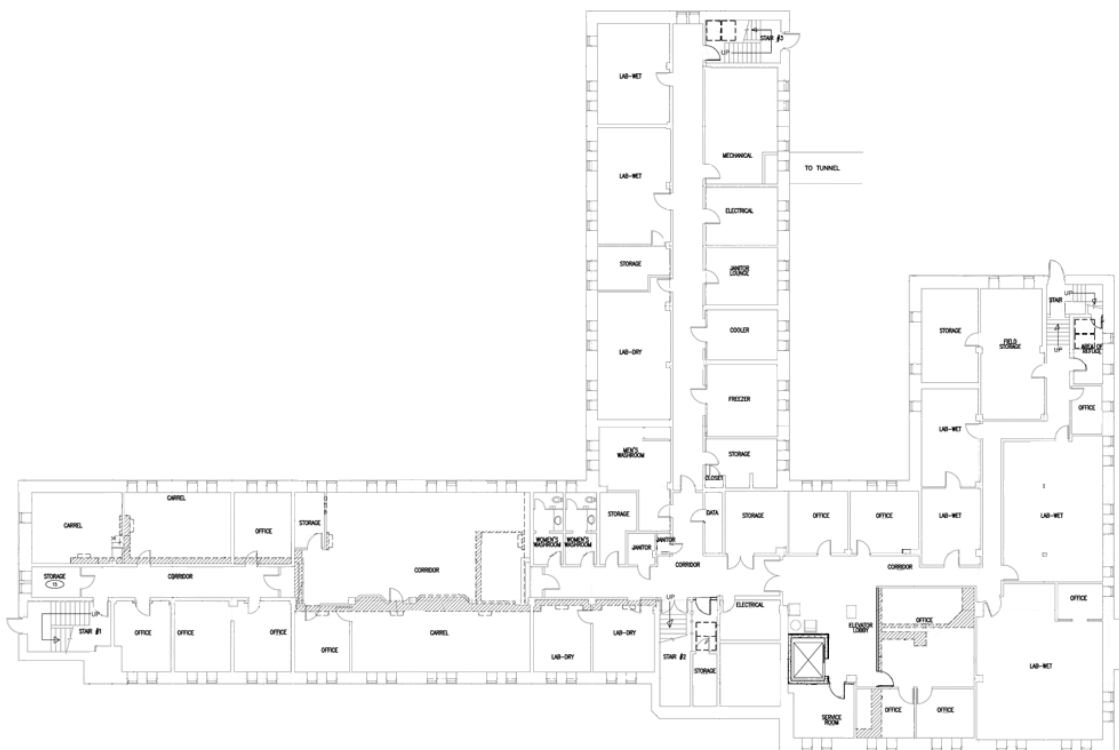

Figure 27. The configuration of the basement level at the time of this report. Retrieved from Facilities Management Division Asset Record System, File 031 KH-226-AB.



Figure 28. The common room, now a lecture room, has a heigh ceiling.



Figure 29. The lecture room. The doors on the left have been removed.



Figure 30. The basement cafeteria. Photo A-481 retrieved from http://scaa.sk.ca/gallery/uofs_buildings/

2.5 Systems

Limited original drawing information is available; however, the structure of Kirk Hall appears to be a structural steel frame, consisting of steel joists, beams and columns on cast-in place concrete foundation walls and footings. Floors and roofs are concrete slabs on steel joists. Exterior walls are non-structural and consist of brick, with a layer of hollow clay tile and painted plaster.

The original specifications show that Kirk Hall featured an intercom system connected to each of its four floors. The building's kitchen also had an intercom connection to the kitchen that existed in [Saskatchewan Hall](#) at the time. There was no evidence of these systems in existence at the time of this report.

Kirk Hall was the first building at the university to have electrical outlets for automobile block heaters specified, a consideration which marks the beginning of design for the convenience of drivers.

2.6 Use(s)

The School of Agriculture, as it was originally called, was constructed in part with Dominion (or federal government) funds. The contract with the government prohibited the use of the building for anything other than agricultural purposes for a period of 10 years. Accordingly, the building was originally used to house, feed and educate students in the College of Agriculture. In 1991, the College of Agriculture moved into the newly constructed Agriculture Building.

Originally, Kirk Hall's basement held a cafeteria, kitchen, student lounge, staff lounge, recreation room, residence rooms, two dining rooms, a sitting room, a rubbish room with an incinerator and various service rooms. Figure 30 shows the basement being used as a cafeteria. The recreation room is now a large open space with chairs and tables. The residence rooms that were located in the north corridor have become laboratory and office spaces. The kitchen and cafeteria space has been subdivided to make room for more offices and labs. Documentation suggests that the cafeteria was not used for food preparation, but that food was prepared in Saskatchewan Hall and transported by truck. The former dining spaces are now used for storage.

The ground floor residence rooms have been converted into offices and meeting rooms. The lecture room (Figure 31) has retained its use, and a former common room (Figure 32) is now a large classroom. Plans for this floor, dated May 1, 1947, indicate that at one time it was used by other departments as different

rooms have been labeled: Math, French, English and Homecraft. The first and second floors were originally used almost exclusively as dormitory rooms (Figure 34). At the time of this report they are offices for the departments of Geography & Planning and Native Studies.

2.7 Cultural & Chronological Associations

Kirk Hall is associated with its namesake, Lawrence Eldred Kirk. Kirk was Dean of Agriculture for the years 1937 through 1947. The School of Agriculture was renamed Kirk Hall in 1962. Kirk's research was concerned with breeding forage crops. Most notably, he developed a variety of wheat grass hardy to the Saskatchewan climate. Many of the crops developed by Kirk are still used in farming on the prairies today. Kirk was awarded the Saskatchewan Centennial Leadership Award posthumously in 2005 and is a member of the Saskatchewan Agricultural Hall of Fame.



Figure 34. Dormitory room. Photo A-495 retrieved from <http://sain.scaa.sk.ca/items/index.php/university-of-saskatchewan-archives;jsdiah>

Kirk Hall is also associated with the College of Agriculture, for which it was built. This association lives on through the location of Kirk Hall in the 'agriculture group' of buildings. Its yellow brick also identifies it as part of this group of buildings.

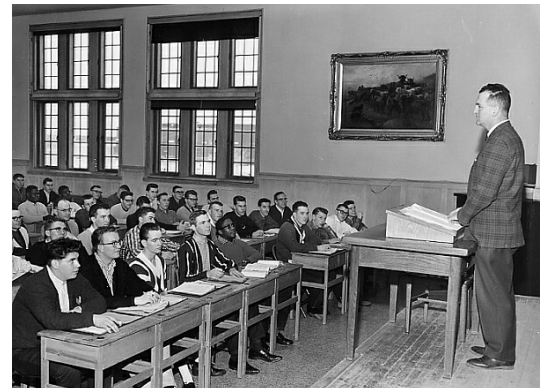

Figure 31. The lecture room in use. Photo A-1581 retrieved from http://scaa.sk.ca/gallery/uofs_buildings/



Figure 32. The common room in its original use. Photo A-488 retrieved from <http://sain.scaa.sk.ca/items/index.php/university-of-saskatchewan-archives;jsdiah>



Figure 33. The library. Photo A-489 retrieved from University of Saskatchewan Archives.



3. Associated Objects

N/A

4. Supporting Documents

Author Unknown. (March 8, 2008). Raising the Roof on Kirk Hall. *On Campus News*, 15(14). Retrieved from http://news.usask.ca/archived_ocn/08-mar-28/2.php.

Author Unknown. (Winter 2006). 'Visiting Kirk Hall'. *The Green and White*. Retrieved from <http://www.usask.ca/greenandwhiteissues/2006/winter2006/features/alumnews.php>.

Facilities Management Division (2011). Asset Resource Database [Data File]. Retrieved from \\usask\fmddfs\files\iis\IIS_Public\ARS

Macpherson, C. (September 5, 2008). 'In Praise of Older Buildings'. *On Campus News* 16(2). Retrieved from http://news.usask.ca/archived_ocn/08-sept-05/editornote.php.

University of Saskatchewan Archives. (Retrieved 2012). *Campus Buildings: School of Agriculture*. Retrieved from http://scaa.sk.ca/gallery/uofs_buildings/

University of Saskatchewan Archives. (Retrieved 2013). *Campus Buildings: Soils and Dairy Science Building*. Retrieved from http://scaa.sk.ca/gallery/uofs_buildings/.

University of Saskatchewan Archives, School of Agriculture Addendum A. Directors Correspondence 4. Building 1948-50.

5. Summary of Character - Defining Elements

Materials	<ul style="list-style-type: none">▪ yellow brick walls▪ Indiana limestone trim▪ grey granite base course▪ quarry tile flooring▪ coloured ceramic wall tile▪ wood: oak, birch, maple, fir, pine▪ slate chalkboards▪ steel window frames and stairs▪ iron balustrades▪ terrazzo flooring and treads▪ brass hardware▪ brick fireplaces
Form & Style	<ul style="list-style-type: none">▪ asymmetrical massing▪ Norman tower▪ scale
Location	<ul style="list-style-type: none">▪ proximity to other buildings of the College of Agriculture▪ outside the 'Bowl'
Spatial Configuration	<ul style="list-style-type: none">▪ double-loaded corridors▪ auditorium▪ lounges▪ central stair
Uses	<ul style="list-style-type: none">▪ student residence▪ cafeteria▪ agricultural education▪ library
Cultural & Chronological Associations	<ul style="list-style-type: none">▪ Lawrence Eldred Kirk▪ agricultural education



035

Williams Building



035

Williams Building

Alternate Names

School for the Deaf

R.J.D. Williams Provincial School for the Deaf

Architect(s)

Harold Dawson, Provincial Architect, Government of the Province of Saskatchewan Department of Public Works, Regina

Builders

R.J. Arrand Contracting Co.

Construction Dates

January 1930-1931

Recognition

University of Saskatchewan 'B' Listed

1. Statement of Significance

The Williams Building is a handsome brick structure, designed in a simplified Collegiate Gothic style by the office of the Provincial Architect, Harold Dawson, and constructed in 1931. It was originally built as a School for the Deaf, commissioned by the provincial Department of Education. It was a residential school, with an enrolment of 114 students between the ages of 6 and 18. The school was used for education in vocational work as well as drama productions and sports. In 1990, deaf children were integrated into the public school system, and the building was sold to the University of Saskatchewan. The Williams Building has significant commemorative integrity in its exterior style and materials. The interior has lost most of its heritage value, as the commemorative integrity of its interior layout, stylistic elements and materials has been compromised by renovations.

Note: The Williams Building is configured with floors numbered Basement, First Floor, Second Floor and Third Floor. This report follows the same convention.



Figure 1. Red brick, artificial limestone and copper grille.



Figure 2. Tyndall stone.

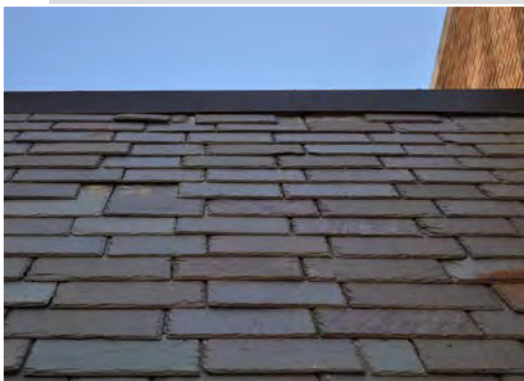

Figure 3. Slate tile roofing.



Figure 4. The Williams Building, October 1945. Photo A-1865, retrieved from http://spldatabase.saskatoonlibrary.ca/internet/LHR_RADQuery.htm



Figure 5. Oak door.



Figure 6. Stained glass.

2. Character - Defining Elements

2.1 Materials

The exterior of the Williams Building is composed of a red-brown facing brick made at Claybank, Saskatchewan and a structural brick made at Estevan. The brick is accented with Tyndall stone and a precast concrete product made to resemble cut limestone. The brick and artificial stone are shown in Figure 1 and the Tyndall stone in Figure 2. The artificial stone around the windows as well as the partition blocks were made in Saskatoon. The Tyndall stone surrounding the doorways came from Manitoba. Exterior hardware such as down spouts and ventilation grilles are made of copper (Figure 1). Copper, Tyndall stone and limestone are all materials common to the main campus at the University of Saskatchewan, and are character-defining materials of the Williams Building. Slate tile roofing is also commonly found on campus. The Williams Building roof was originally slate, but has been replaced with asphalt shingles. Two newer additions have been built with slate tile (Figure 3). For further information on building stones used at the U of S, refer to [Appendix: Stone](#).

Oak (Figure 5) was used for doors and frames. All of the original oak material has been replaced except for the transoms and lites around the two northernmost entrances. The quarter-sawn oak around these doors and their stained-glass transoms are character-defining elements (Figure 6).

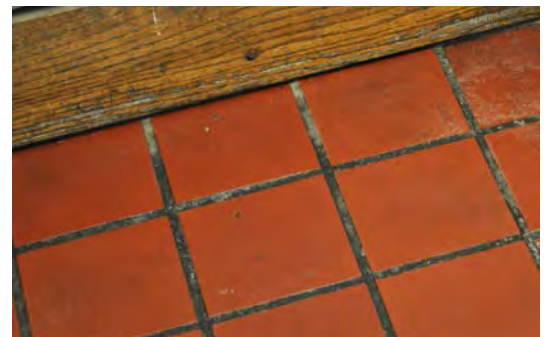

Figure 7. Red clay terra cotta tile located inside the principal entry.



Figure 8. Brick wainscoting.

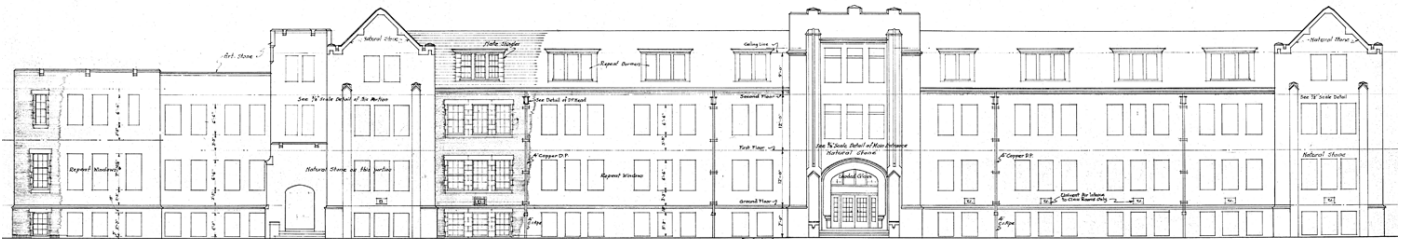

Figure 9. The original west or front elevation of the Williams Building. Retrieved from Facilities Management Division Asset Record System, File WILL-10-T.



Figure 10. The form of the Williams building in 1943 before the renovations. The high chimney pictured here was removed. Retrieved from http://spldatabase.saskatoonlibrary.ca/internet/LHR_RADQuery.htm

The interior of the Williams Building holds very little heritage value in its materials, as almost all of its original materials have been replaced. The red terracotta floor tiles in the main entrance hall are original. Shown in Figure 7, this tile is in excellent commemorative condition.

Some brick wainscoting is still found in the anterooms to the gymnasium (Figure 8). The walls of the gymnasium have been covered with carpet. The original brick wainscoting may exist beneath the carpet. Building plans show that brick wainscoting with plaster walls and ceiling were a common material throughout the entire building. Existing brick wainscoting is a character-defining element of heritage value. The rest of the materials of the auditorium have been compromised; the wooden floor has been replaced with a vinyl composite tile, and the original ceiling has been concealed by a dropped ceiling.



Figure 11. The Williams Building in its surrounding context in the early 1970's. Retrieved from *The First Fifty Years: R.J.D. Williams Provincial School For the Deaf.*

Many materials specified in the plans no longer exist in the building. The original floor plan show terrazzo and maple flooring. Concrete floors were used originally for the playrooms. Brick wainscoting with plaster walls and ceiling were common materials throughout the entire building. A proprietary material called 'J.M. Flooring Tile' was specified for the buildings corridors, but has since been removed. None of the original blackboards remain in the building.

2.2 Form

The Williams Building takes the form of a modified 'F' in plan, with double-loaded corridors serving the central volume of the building. As shown in Figure 9, the Williams Building is asymmetrical, with two principle entries. The Williams Building sits at a scale of three storeys above ground with a half-exposed basement level. The building is 28 metres in length. The height and length of the façade lend the building an imposing presence. The scale of the building has not changed, and as such is a character-defining element. Figure 10 shows the form of the building before renovations. Figure 11 shows the form of the building after the 1970's additions were carried out.

None of the original form of the building has been demolished but several additions have been made. The most notable addition has been to the massing of the auditorium. When the space was renovated to become a gym, its area and volume became larger. Despite this change, the exterior form of the Williams Building retains good commemorative integrity, and its front elevation has changed very little.

2.3 Style

The Williams Building is Collegiate Gothic in its architectural style. Character-defining elements include the carved stone entries and their accompanying gothic arch transoms (Figure 12). String courses and quoining around the windows are also character-defining elements of the gothic style in good commemorative condition (Figures 12 & 13). The cut stone above the principal entry features trefoil and quatrefoil arches (Figure 15). The foliated cut stone ornamentation around the doors is also a character-defining element (Figure 16). The cut stone detailing serves to enhance the verticality of the building.



Figure 16. Foliated cut stone ornamentation.



Figure 17. Crenellated parapet.



Figure 12. Gothic arch and transom.



Figure 13. Tyndall stone string course.



Figure 14. Stone quoins around windows, an archer slot window.

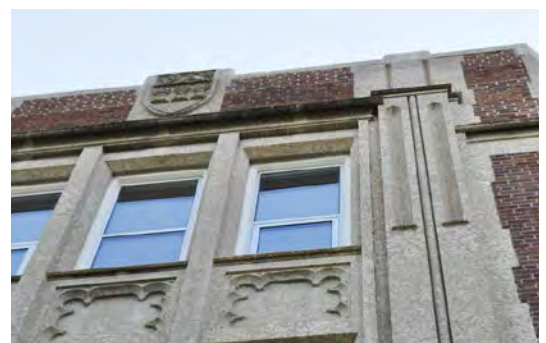

Figure 15. Gothic trefoil arches and the Sasaktchewan crest carved into the vertical stone elements surrounding the principal entry.



Figure 18. Dormer windows.



Figure 19. Arched windows.

The roofline features a crenellated brick and stone parapet (Figure 17) on tower elements marking the two front entrances, gables and a pitched roof punctuated by dormer windows. The dormer windows have been maintained in their style but their materials have largely been replaced (Figure 18). The building also features narrow archer style windows surrounded by cut stone (Figure 14). The auditorium or gym still features double-height arched window openings, although the windows themselves have been replaced and covered with bars on the interior and the lower portion of the windows has been covered with brick, as shown in Figure 19. The arched windows lend character to both the interior and the exterior of the building. Figure 20 illustrates many of the character-defining elements of the building's exterior.

In the interior of the building, few gothic stylistic elements remain. The stained glass transoms above the entrances are visible from the interior of the building. Several other gothic character-defining elements have been lost to renovations. The auditorium used to have another set of arched windows that have been demolished. The building plans specified arched entries to the dormitory rooms located in the tower. With the reconfiguration of the tower these arched openings were removed.



Figure 20. Gable and tower details including gothic arch entry, trefoil spandrels, crenellated parapet, cut stone quoins, tower and statuary niche references. Retrieved from Facilities Management Division Asset Record System, File WILL-12-T.

2.4 Location

The location of the School for the Deaf, on Cumberland Avenue in Saskatoon, was a strategic choice (Figure 22). Dean R.J.D. Williams advised that the school not be in the capital (Regina), but in Saskatoon where it could govern itself with greater independence. Williams also related that he would like to see the school built near another school, to provide its students the opportunity for athletic competition. Williams recommended to J.G. Gardiner, then Premier of Saskatchewan, “that the Saskatchewan School for the Deaf be established in close proximity to the University of Saskatchewan. I cannot help but see a great future for the deaf if this plan is carried out.”

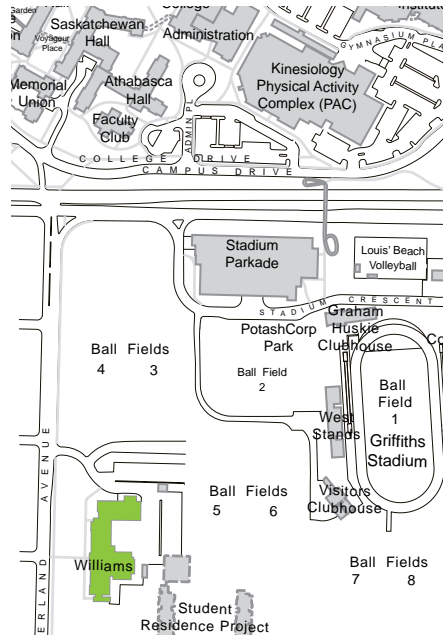

Figure 22. The location of the Williams Building is indicated in green on a contemporary campus plan.

2.5 Spatial Configuration

At the end of the 1960's a total renovation of the school was announced and in the early 1970's architects Holliday-Scott, Paine and Associates undertook this work. An elevator and stairwell were added to the south end of the building, which has affected the layout on all levels. To the north side of the building, a small addition featuring a ground floor loading dock was added. Figure 23 shows the building's exterior before the renovations. The high chimney protruding from the basement boiler room was removed. The south facing windows were all covered by additions.

The basement originally had large open areas for the boys play room and carpentry shop. These have been enclosed and the basement is now substantially reconfigured. A daycare is now located in the south-west corner of the basement. Figure 24 shows the original configuration of the basement.

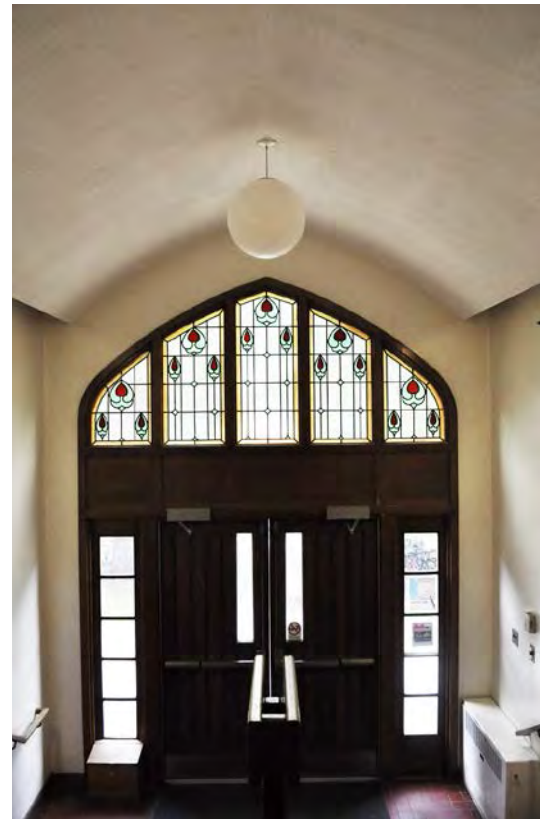

Figure 21. Gothic arch transom.



Figure 23. A 1949 photo of the building shows its exterior before the 1970's renovations. Retrieved from *The First Fifty Years: R.J.D. Williams Provincial School For the Deaf*.

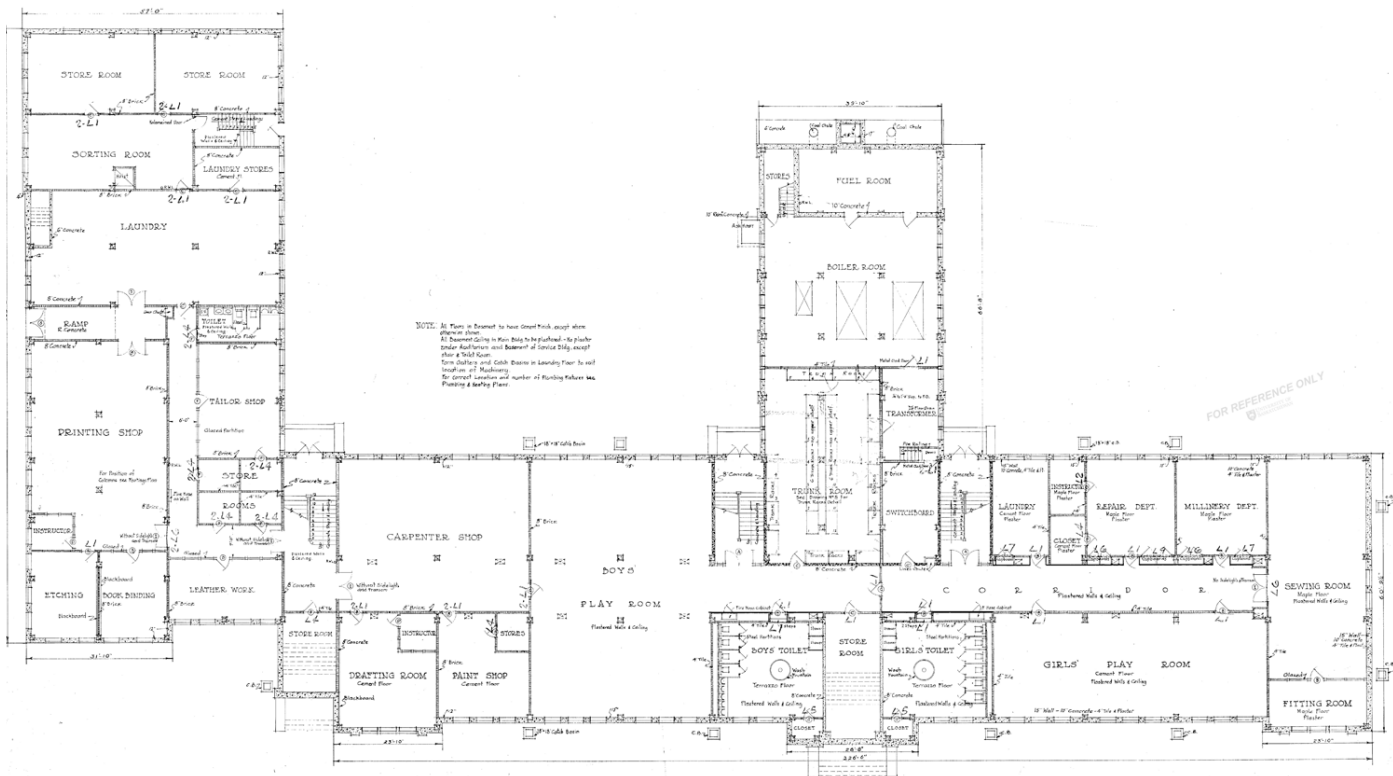

Figure 24. The original basement configuration of the Williams Building. Retrieved from Facilities Management Division Asset Record System, File WILL-4-T.



Figure 25. A photo, ca. 1945, shows how the auditorium was originally configured. Retrieved from *The First Fifty Years: R.J.D. Williams Provincial School For the Deaf*.

The most notable change to the spatial configuration of the building has been the expansion of the auditorium on the main floor to become a gymnasium. The expansion saw the removal of several south-facing arched windows. The windows still existing in the space have had their bottom portions filled in with brick. The stage and the open gallery overlooking this space from the second floor have also been removed. A staircase at the west end of the gymnasium has been added. Figure 25 shows an interior view of how the auditorium was originally configured with a stage.

Figure 26 shows the original main floor plan including the layout of the auditorium. Figure 27 shows the expansion and reconfiguration that converted the auditorium into a gymnasium. Outside the auditorium, the first floor has retained its configuration, arranged around a double-loaded corridor. Some rooms have been expanded through the deletion of partition walls. The northeast portion of the main floor has seen significant reconfiguration with its conversion from a dining area to a series of research gymnasiums and offices.

The second and third floors of the Williams Building have retained their configuration as a series of rooms arrayed along a central double-loaded corridor (Figure 28).

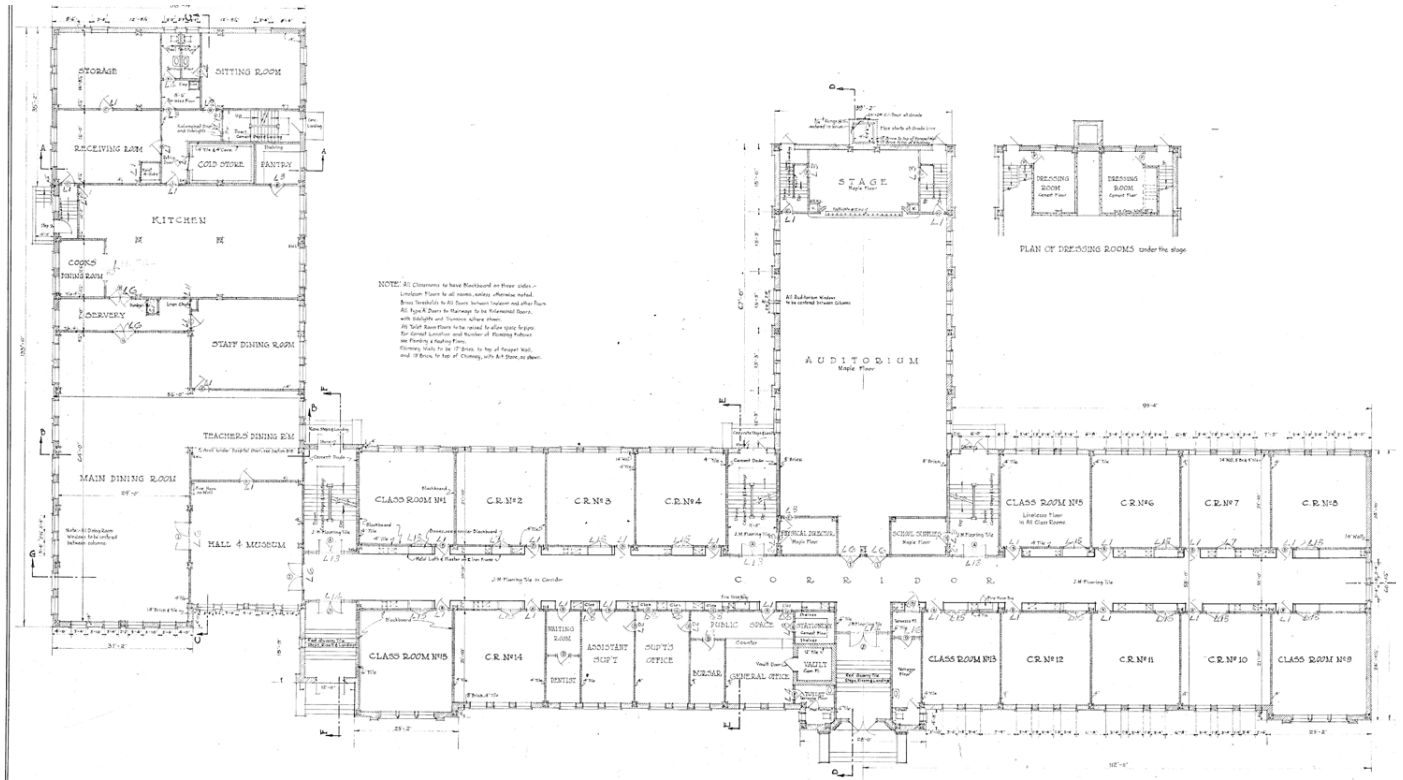

Figure 26. The original first floor plan of the Williams Building. Retrieved from Facilities Management Division Asset Record System, File WILL-5-T.

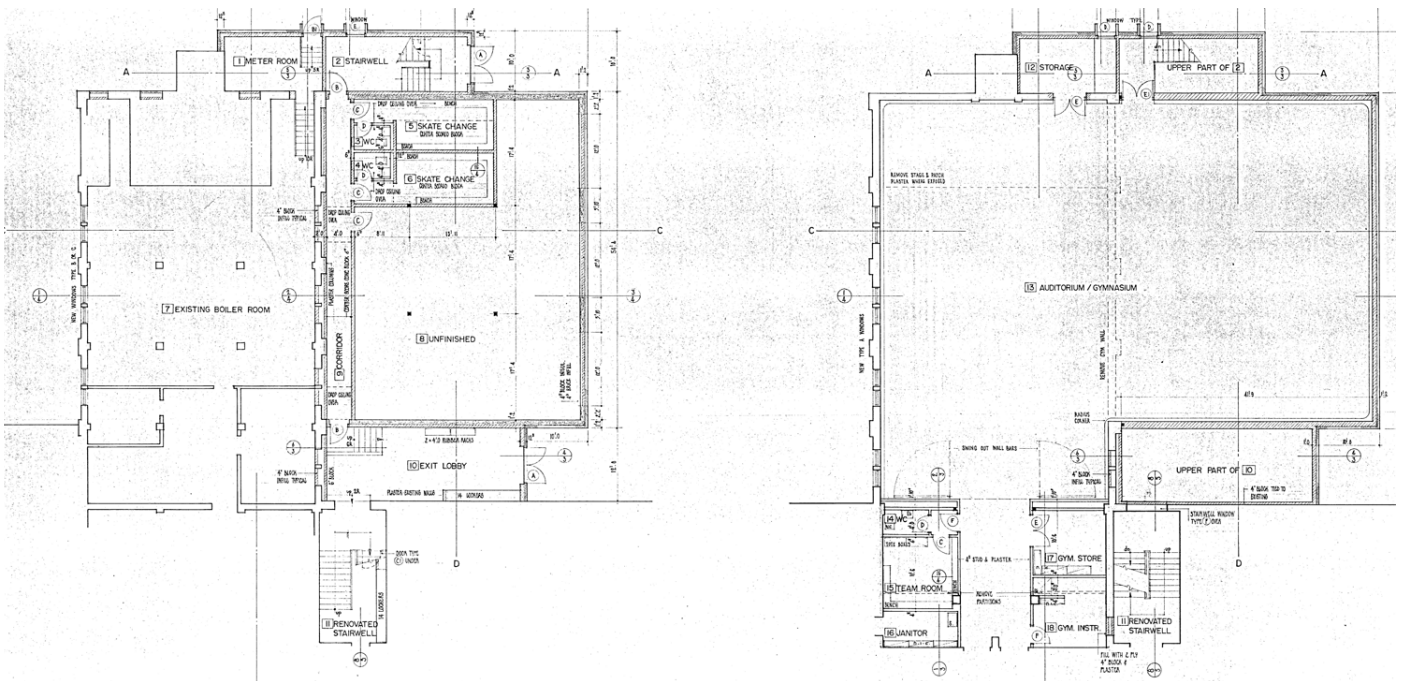

Figure 27. The expansion of the auditorium, L to R: the basement plan, the first floor plan. Retrieved from Facilities Management Division Asset Record System, File WILL-147-T.

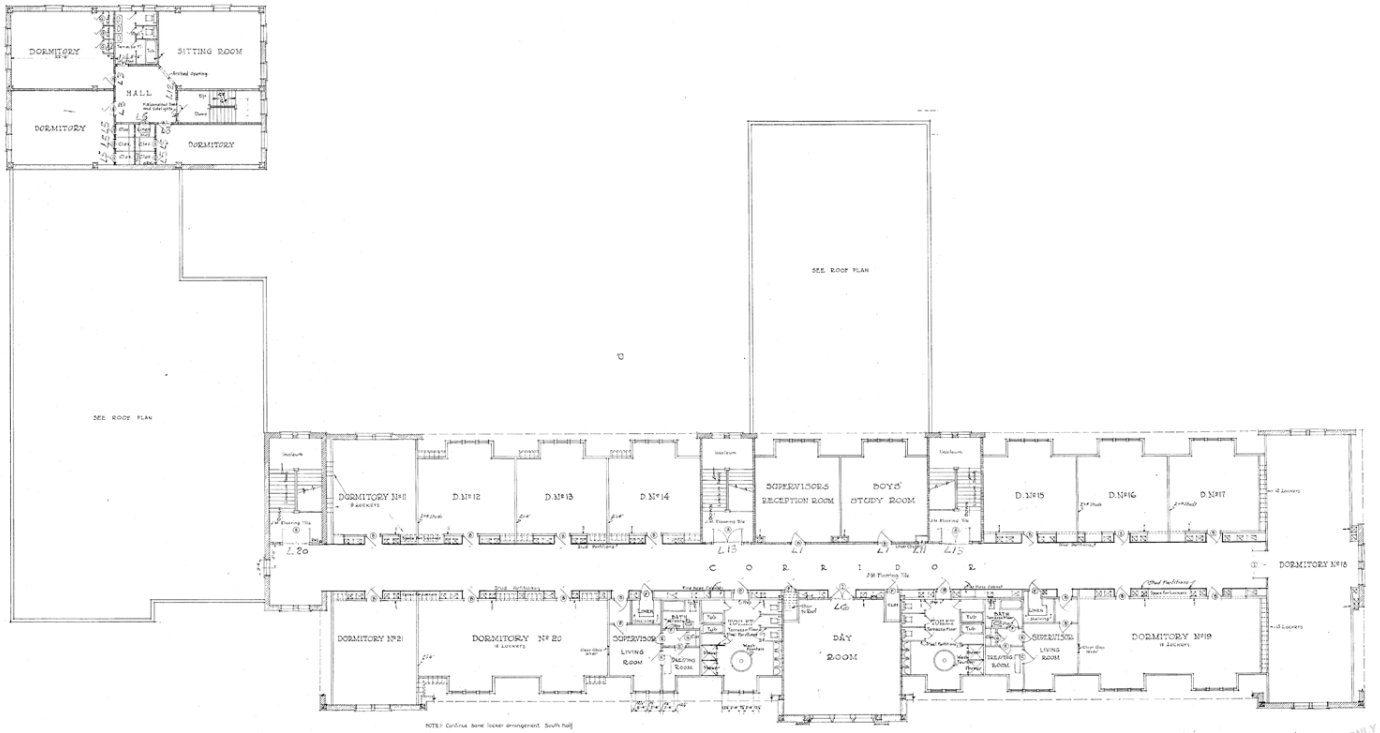

Figure 28. The original third floor plan of the Williams Building. Retrieved from Facilities Management Division Asset Record System, File WILL-7-T.

2.6 Systems

The structure of the Williams Building appears from the original drawings to be a cast-in-place concrete frame. Floors are composed of cast-in-place concrete on a ribbed metal lath overlaid with steel tile and concrete. The foundation walls and footings are in cast-in-place concrete, and roofs are framed in a combination of steel and wood. Figure 29 shows a typical exterior wall section.

2.7 Use(s)

Owing to the specific training required for deaf children, the School for the Deaf originally accommodated a wide assortment of uses. The curriculum was based on vocational training, including a broad range of activities such as carpentry, leatherwork, book binding, etching, printing, drafting, painting, sewing and millinery. These activities were all housed in the basement and had their own dedicated shops or labs. To support them, the basement also held a fitting room, a repair department, as well as a boiler and fuel room. Large play rooms were also contained within the basement. Many other types of vocational training were undertaken there including hairdressing, cooking, bee keeping, gardening, welding and meat cutting (School for the Deaf Book Committee, 1983). Figure 30 shows students working in a metal shop in the basement of the Williams Building.

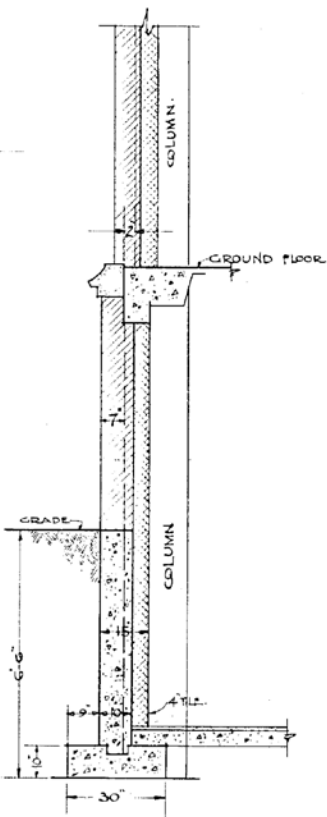

Figure 29. Typical exterior wall section. Retrieved from Facilities Management Division Asset Record System, File WILL-37-T.

No physical evidence of the former uses or their configurations remains in the building.

The first floor of the building housed more common uses. The auditorium held social functions such as performances, graduations and awards ceremonies. Figure 31 shows the auditorium being used for a drama production. The first floor also held classrooms, and a general office with a vault. Figure 32 shows a classroom in use. The first floor is still used for office space and classrooms; the vault is still in place. The northeast portion of the first floor was originally used as a kitchen, servery and dining room. A hall and museum were also located here. The kitchen, hall and museum have been replaced by research gymnasias. Figure 33 shows the northeast portion of the first floor being used as a dining room.

The second and third floors of the building were both used as dormitories (Figure 34). This use has been discontinued and these floors now contain classrooms and offices.



Figure 33. The dining room in 1940. Retrieved from *The First Fifty Years: R.J.D. Williams Provincial School For the Deaf*.



Figure 34. The girls dormitory. Retrieved from *The First Fifty Years: R.J.D. Williams Provincial School For the Deaf*.

Although the specific uses of this building associated with its history as a school for the deaf have ended, it continues to be used for similar educational purposes.



Figure 30. The basement metal shop, 1960. Retrieved from *The First Fifty Years: R.J.D. Williams Provincial School For the Deaf*.



Figure 31. A 1939 performance of "Snow White and the Seven Dwarfs" in the auditorium. Retrieved from *The First Fifty Years: R.J.D. Williams Provincial School For the Deaf*.



Figure 32. A 1945 class. Retrieved from *The First Fifty Years: R.J.D. Williams Provincial School For the Deaf*.



Figure 35. The original sign.



Figure 36. The cornerstone.



Figure 37. Monument honoring former Premier J.T.M. Anderson.

2.8 Cultural & Chronological Associations

The Williams Building is associated most notably with its namesake, Rupert J.D. Williams. Williams was the dean of the school from its opening in 1931 until 1963. Williams was rendered deaf in his childhood by spinal meningitis and attended Manitoba's school for the deaf. He moved to Saskatoon in 1927 and undertook a review of the education of deaf children in Saskatchewan. Williams died in 1973. In 1982, on the occasion of the 50th anniversary of the school, the building was renamed in his honor.

The original function of the Williams Building associates it with education of the deaf in Saskatchewan. The sign above the door of the school is a character-defining element marking this cultural association (Figure 35).

James Thomas Milton Anderson was the Premier of Saskatchewan at the time of the construction of the Williams Building. On September 27, 1930 Anderson laid the building's cornerstone (Figure 36). A granite monument to honor Premier Anderson was erected in front of the building (Figure 37).

3. Associated Objects

Behind the cornerstone is a cavity containing a time capsule (School for the Deaf Book Committee, 1983). The cornerstone and the contents of the time capsule are heritage objects associated with the building (Figure 36).

4. Supporting Documents

Saskatchewan Archives Board. Ed. Department of Education (15) General Correspondence (1922-1940).

Facilities Management Division (2011). Asset Resource Database [Data File]. Retrieved from \\usask\fmddfs\files\iis\IIS_Public\ARS.

School for the Deaf Book Committee. *The First Fifty Years, 1932-1982: R.J.D. Williams Provincial School for the Deaf*. Saskatoon: Prairie Graphics Ind. Ltd.

University of Saskatchewan Archives. (Retrieved 2012). *Campus Buildings: Williams Building*. Retrieved from http://scaa.sk.ca/gallery/uofs_buildings/



5. Summary of Character - Defining Elements

Materials

- brick walls
- tyndall stone decoration and trim
- oak doors & millwork
- stained glass windows

Form

- scale

Style

- gothic arch entries
- cut stone arches
- arched windows
- crenellation
- parapets (battlements)
- archer style windows

Location

- near University of Saskatchewan

Spatial Configuration

- double height auditorium
- north-east tower
- double-loaded corridor
- sloped roofs

Uses

- school for the deaf
- classrooms
- dormitories
- kitchen, dining room, servery
- vocational training
- play rooms
- sick wards
- auditorium/gymnasium

Cultural & Chronological Associations

- J.T.M. Anderson
- R.J.D Williams
- sign reading 'School for the Deaf'
- cornerstone & time capsule



039

Little Stone School House

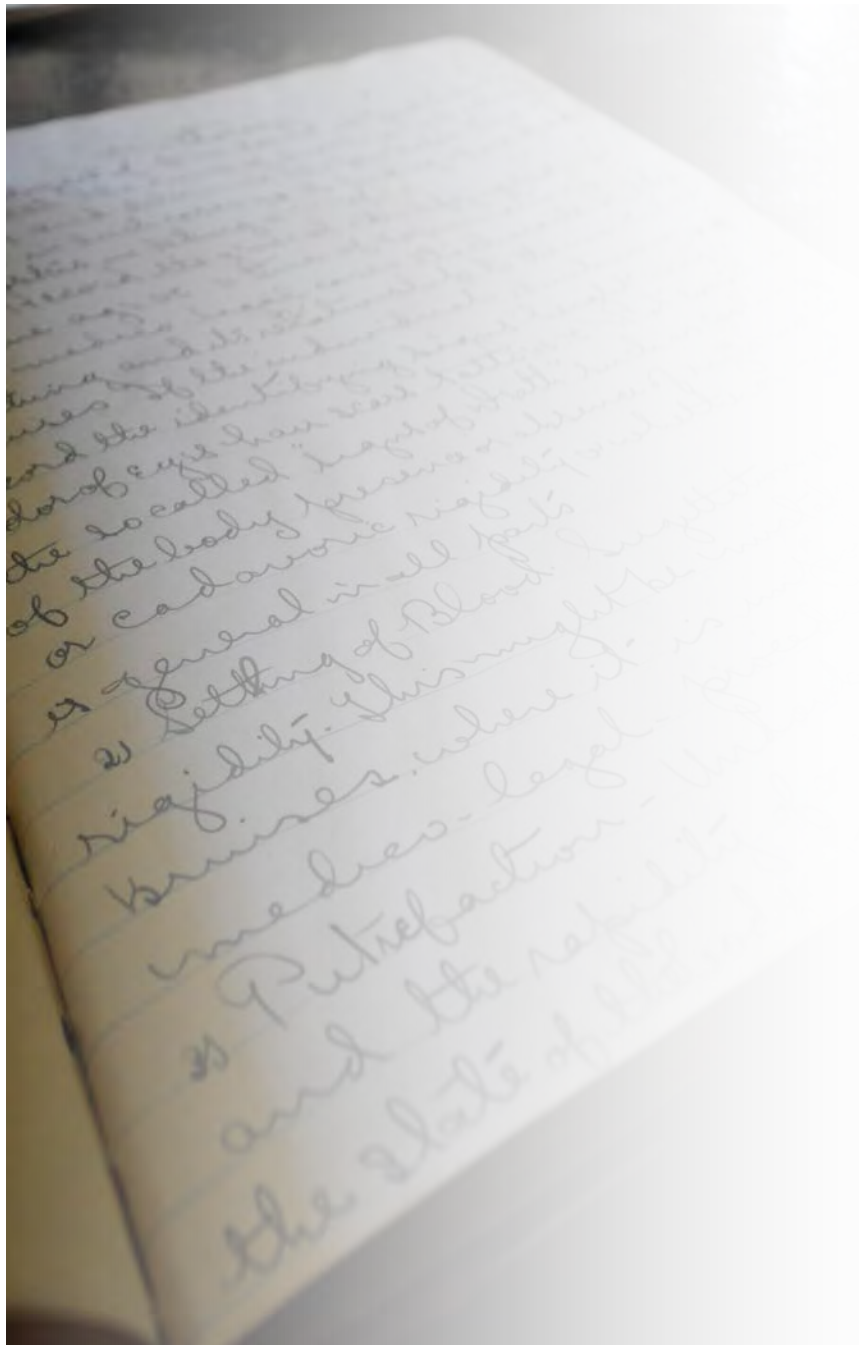

039

Little Stone School House

Alternate Names

Victoria School

Designer

Alexander Marr

Builders

Alexander Marr, Nutana settlers

Construction Dates

1887

Recognition

Provincial Heritage Property, Designated in 1982

Municipal Heritage Property, Designated in 1967

University of Saskatchewan 'A' Listed

1. Statement of Significance

In 1887 the Saskatoon Board of Trustees secured five lots for a permanent school site. Later that year, the original Victoria School (now known as the Little Stone School House) became Saskatoon's first permanent school and its first public building in any capacity. By 1905, the one-room school house was no longer needed, as a two room school had been built to accommodate its growing student population. In 1909, a new Victoria School was built, assuming the function of the Little Stone School in its original location. Figure 1 depicts the larger Victoria School with the Little Stone School in the foreground, around 1910.

W.P. Bates proposed the relocation of the original Victoria School from Nutana to the University of Saskatchewan. In 1911 the Imperial Order Daughters of the Empire (I.O.D.E.) Golden West Chapter, raised funds to preserve and relocate the building. Its stones were carefully dismantled, numbered and reassembled at their new location. The Little Stone School House is one of two surviving buildings constructed by Alexander Marr, an early and influential citizen of Nutana.



Figure 1. The newly constructed Victoria School (centre) circa 1910, with the Little Stone School House (right). To the left is a two room school house, built after the Little Stone School and before Victoria School, ca. 1910. Photo A-889 retrieved from http://scaa.sk.ca/gallery/uofs_buildings/.



Figure 2. June 2 1967, the Little Stone School reopens to the public. Photo A-4559 retrieved from http://scaa.sk.ca/gallery/uofs_buildings/.

In 1965 The Saskatoon Council of Women raised money for the renovation of the building as part of a Centennial Project. Figure 2 shows the reopening ceremony held on June 2, 1967. In 1981 the University of Saskatchewan took over the operation of the building (Figure 3). The Little Stone School House was recognized as a Municipal Heritage Site in 1967 and a Provincial Heritage Property on May 17, 1982.

2. Character - Defining Elements

2.1 Materials

The exterior of the Little Stone School Houses is constructed of prairie stones that were collected by settlers at the time of construction. Pink, red and gray granite, dark grey and black diorite and gabbro and dolomitic limestone or 'greystone' are all visible on the building's exterior.* Since the settlers gathered the stones, the building is a product of community labour. Wood was used for the single door and the window frames and trim. A brick chimney protrudes from a roof shingled with wood.

The interior of the school retains its wooden floor. The interior walls are plaster, the lower portion of the interior walls are faced with painted wood. The window shutters are made of painted wood as well. Figure 4 shows these elements.

*For further information on building stones used at the University of Saskatchewan, refer to ['Appendix: Stone.'](#)

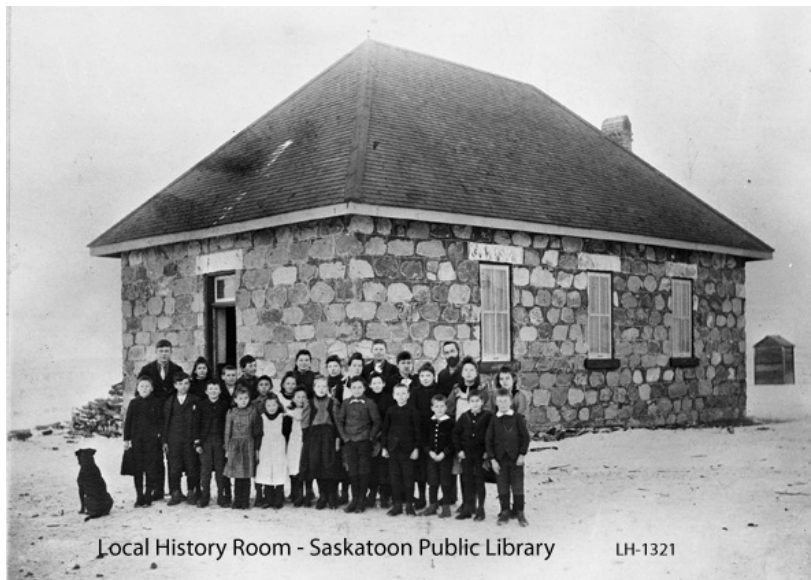

Figure 5. Teacher George Horn with his class in front of The Little Stone School House ca.1894 in its original location on Broadway Avenue. Photo LH-1321, retrieved from <http://spldatabase.saskatoonlibrary.ca/>



Figure 3. May 12, 1981, President L. F. Kristjanson receives the key to the Victoria School House from E. Hirsch, President of the UFLSS Society. Also present, left to right, are F. Andrews, N. Dennison, and E. Holmes. Photo A-6666 Retrieved from http://scaa.sk.ca/gallery/uofs_buildings/.



Figure 4. Wood-paneled interior wall and wooden floor. In the background a wooden door is visible. The photo also features some objects associated with the historical period of the school house such as a lunch bucket, school bell, chamber pot and spectacles.



Figure 6. The current location of the Little Stone School House is indicated in green on this contemporary campus plan.



Figure 7. On the building's southeast corner, an upside-down '3' is visible on a rock. This marking is a trace of the process used to disassemble and reassemble the building.

2.2 Form

The form of the building reflects the original intention of its builders to quickly and effectively provide a permanent space for education. The one storey building consists of a single room with a hipped roof; all that was needed to fulfill the purpose. Although the school house has been relocated to its current site at the university, its modest height and scale allow it to inconspicuously coexist with the neighbouring neo gothic buildings. Refer to Figure 5.

2.3 Style

The Little Stone School House cannot be classified as belonging to any particular architectural style, but is an example of the simple vernacular buildings typical of the early settlement of Saskatoon and western Canada. The use of stone would have differentiated it as an institutional building among the houses built in the neighbourhood of Nutana at the time of its construction. In its current location at the university, the stonework of the facade makes the building sympathetic to the rest of the campus, but its small scale and lack of decoration distinguish it from its current surroundings.

2.4 Location

The Little Stone School house was originally located at what is now the corner of Broadway Avenue and 12th Street, a spot known as the 'Five Corners'. It stood here until the early 1900's, originally serving the hamlet of Nutana. The relocation of the school house is an aspect of its history that contributes to its character and heritage value. In 1909, the building was no longer required for its original purpose, and faced demolition. W.P. Bates proposed that it be relocated. The local chapter of the Imperial Order Daughters of the Empire (I.O.D.E.) raised funds for the undertaking and in 1911 the stones of the School House were carefully numbered, disassembled and reassembled on the campus of the University of Saskatchewan (Figure 6). The Little Stone School House currently resides on the U of S Campus adjacent to College Drive. It is framed by the [Health Sciences](#), [Dentistry](#) and [St. Andrew's College](#) Buildings.

As Figure 7 demonstrates, the Little Stone School House bears reminders of its relocation. In at least one instance, a number is visible, as a reminder of the process of relocation.

2.5 Spatial Configuration

The 'one room schoolhouse', of which the Little Stone School House is a typical example, is a building type common to the early history of Saskatchewan. Therefore, the spatial configuration of the Little Stone School House is an element of historical value with respect to its prairie context.

The eastern and western walls of the school feature windows which would originally have provided the main light source for the space. Figure 9 shows a window complemented by a gas lamp with a reflector, which would have supplemented natural light at night. The use of natural lighting is a character-defining element.



Figure 9. A wooden window frame and shutters. These shuttered windows allowed for the spaces illumination. When natural light was not accessible, gas lamps with reflectors such as the one pictured would have to be used.

The building is accessible through a single door on its north face. Upon entrance, visitors are greeted by a small vestibule. Beyond the vestibule is the single classroom. The south side of the school is windowless, providing an uninterrupted surface for the blackboard. This dictates the orientation of the room's furnishings towards the south of the room so that pupils face towards the chalkboard. Figure 8 shows the spatial configuration of this 'one room school house', characteristic of this type of building. The desks were arranged on skids so they could be pushed easily into the ante room to make space for social events.



Figure 8. The spatial configuration of the one room school house. Desks oriented towards the chalkboard with the stove in the centre of the room.



Figure 10. The Marr Residence. Alexander Marr was the mason who built the Little Stone School. The Residence and School make up the only two remaining structures by Alexander Marr.



Figure 11. Plaque on the entrance to the Little Stone School commemorates the move of the building to its current location through the efforts of The Imperial Order of Daughters of the Empire.

2.6 Systems

The masonry walls of the Little Stone School House provide its primary structure. They also help to define its historical character, since load bearing masonry walls were a common feature of early architecture in the province, but are now increasingly rare. The roof structure is not visible, but is assumed to be a system of hipped rafters. The Little Stone School House has maintained the integrity of its structural system.

The school house was heated by a single pot bellied stove. The original stove was located against the back wall of the room. The current stove is not original to the building, but is contemporary with it, and was donated by Mr. J.J. Black of Paynton. It has been refitted to burn gas and now sits in the centre of the room, due to modern regulatory requirements. A large stove pipe conceals the gas supply line. (Refer to Figure 8.)

2.7 Uses

The Little Stone School House is the oldest public building in Saskatoon. At its Nutana location, this building served not only as a school, but also as a meeting house, election centre and dance hall. The School House reportedly had a small collection of books for public loan in the early days. The first Anglican Communion in the city was held here. It served this multi-purpose function from its founding in 1887 until 1905 when a two room school house was built. (See Figure 1). After its relocation, the Little Stone School House was used for storage by the University of Saskatchewan for many years. It was refurbished in 1965 and opened to the public and school tours in 1967. In 1981 the university took over its operations. The building is currently used for tours during the spring and summer.

2.8 Cultural & Chronological Associations

Victoria School was the heart of the neighbourhood of Nutana for a number of years and can be associated with that community. It can also be associated with another municipal heritage property, the Marr Residence. The Marr Residence and the Little Stone School are the only two buildings built by Alexander Marr still surviving. Marr was a prominent Nutana resident. Being one of the largest homes at the time, the Marr Residence was requisitioned and used as a field hospital for Canadian Militia wounded in the North-West Rebellion of 1885. The hospital closed in 1885, shortly before Marr built the Little Stone School. The Marr Residence is shown in Figure 10.

3. Associated Objects

Unfortunately none of the original furnishings of the Little Stone School remain in place. When the Saskatoon Council of women refurbished the building, they collected and furnished it with period objects and furniture. As many of these objects came from other prairie school districts, they associate the Little Stone School with the wider history of education on the prairies.



Figure 12. Plaque associating the Little Stone School with Marjorie M. Clark, the first president of the Little Stone School Society.

A plaque associates the Little Stone School with the Imperial Order Daughters of the Empire, who undertook the relocation of the school (Figure 11). The plaque commemorates an important time in the history of the Little Stone School House when it was decided that the building had heritage value and should be saved rather than demolished. Figure 12 shows another plaque associating the building with one of its contributors. The Union Jack flag visible in Figures 13 and 15 was donated by the Golden West chapter of the I.O.D.E.

Other associated objects include the student desks which were donated by the Saskatoon public school board and West Saskatoon School District of Langham (Figure 13). Most of these desks bear the marks of heavy use over the years by many generations of students.

The teacher's desk pictured in Figure 14 was donated by Miss Pat Hanna of Elstow. The desk was used in the Elstow town school for many years. The chair in Figure 14 originally belonged to Mr. W.M. Holliston, the former principal of Buena Vista Elementary School and the namesake of Holliston School. It was donated by Mr. Tom Porteous, principal of Caswell School.



Figure 13. Pupils desks donated by Saskatoon and Langham School Districts.



Figure 14. Teacher's desk originally used in Elstow school and the chair of W.M. Holliston.



Figure 16. Wood-burning stove.

The pump organ pictured in Figure 15 was donated by Mrs. Jean Foster who attended the Little Stone School in her youth. The organ was made in Detroit in 1883 and sent by train to Moose Jaw in 1888. Railways did not serve Saskatoon until 1890, therefore the organ was brought to Sutherland from Moose Jaw by horse and wagon.



Figure 15. Pump organ; shipped by rail from Detroit to Moose Jaw and hauled by horse and wagon to Sutherland.



Figure 17. A display case contains several associated objects of heritage value.

The clock visible in Figure 13 was used in Victoria School for many years. Also visible are pictures which define the character of the space. The school houses a hand painted picture of Queen Victoria signed by the monarch herself, a picture of the Fathers of Confederation, a picture of Sir Wilfrid Laurier, a family photograph of the first teacher, Mr. James Leslie, a photograph of Sir John A. MacDonald donated by John G. Diefenbaker and several photographs of the school. Photographs of King George V and Queen Mary originated in the Delisle-Donovan area. On the opposite wall are maps and map cases (visible in Figure 16) donated by the West Saskatoon School Unit.

Smaller items associated with the history of the school are a pencil box and a pen, pen holder, paste bottles and a round ruler. An exercise book and report card are also within this building. These objects exist in a fragile state of commemorative integrity and are housed within the display case shown in Figure 17. The display case holds additional associated items: shiny rocks, bird's nests, lumps of coloured glass, and a skull pierced by an arrowhead have all been viewed as objects used for show and tell. The display case also includes a slate used in the Little Stone School in 1902 (Figure 18). Figure 19 shows a lesson book used in the school in 1899.

Further items of heritage value inside the school are the lamps, blackboards, globes, a model of a red river cart, several slates, pencils, easy readers, primers and copy books. A very old pencil box was found on the original site of the Little Stone School and donated. A pen, pen holder, two tuning forks, a pail and cup for drinking water, an old earthen ware drinking fountain, washbasin, towel roller and lunch pails are all on display. Two bookcases hold an impressive collection of historically significant literature including instructional books dating back to 1875.



Figure 18. Mayden Howell's 1902 slate.



Figure 19. Jane Richardson's 1899 Lesson Book

4. Supporting Documents

Author Unknown. (1967, April 13). Another Call for Help from the Little Stone School. *The Western Producer*, pp. 41.

Author Unknown. (1967, June 2). Refurnished historical old stone school officially opened. *Saskatoon Star Phoenix*, pp. 9.

Author Unknown. (1966, November 28). Committee reports progress on refurbishing first school. *The Star Phoenix*, pp. 11. Saskatchewan Archives Board Little Stone School Society of Saskatoon fonds, A377.

Dallas, Z. (1973, August 18). The Little Stone School. *The Star Phoenix*, pp. 14.

Macpherson, J. (n.d.). A member of 1895's Grade 4 class comes to visit.

Mushka, C. (19--, July 4). Little Stone School S.D. No. 13 Northwest Territories 1887. *The Sheaf*, pp. 4(52), 5(53).

Mysyk, W.K. & Kulyk, C.L. (2006). *Saskatoon's Stone*. Saskatoon: Houghton Boston Printers & Lithographers Ltd.

Saskatoon Council of Women. (n.d.). *Background Information*. Saskatoon, SK: Saskatoon Council of Women.

Saskatoon Council of Women. (n.d.). *Items of Interest in the Stone School*. Saskatoon, SK: Saskatoon council of Women.

Saskatoon Heritage Society. (2011). *Designated Buildings: Little Stone School*. Retrieved from http://www.saskatoonheritage.ca/designated/littlestone_schoolhouse.html

The City of Saskatoon. (2011). *Little Stone School House*. Retrieved from <http://www.saskatoon.ca/Departments/Community%20Services/PlanningDevelopment/DevelopmentReview/HeritageConservation/HeritageProperties/Pages/LittleStoneSchoolHouse.aspx>

The Diefenbaker Centre (2011). *Tour Information for The Little Stone School House*. Saskatoon, SK: Leland MacLachlan.

The Little Stone School Society (1974). *The Little Stone School*. Saskatoon, SK: Jessie Caldwell.

Wheeler, E. (1967, June 15). The Little Stone School Officially Opened. *The Western Producer*, pp. 34, 35.

Wood, M.C. (n.d.). *Saskatoon History Hunter Goes to School*.



5. Summary of Character - Defining Elements

Materials

- prairie stone walls (pink, red, gray granite)
- grey and black diorite
- greystone
- wooden door, trim, window frames, shutters and shingles
- brick chimney

Form

- hipped roof
- one storey single massing

Location

- building relocated to University of Saskatchewan in 1911

Spatial Configuration

- one room school house
- vestibule
- natural lighting (originally no electricity)
- orientation towards chalkboard
- stove as heat source

Structure

- load-bearing stone walls

Uses

- education (first school in Saskatoon and early library)
- first public building in Saskatoon (meeting house, dance hall, election centre, first Anglican communion in city)
- museum

Cultural & Chronological Associations

- see uses above
- Marr residence



041

University Club

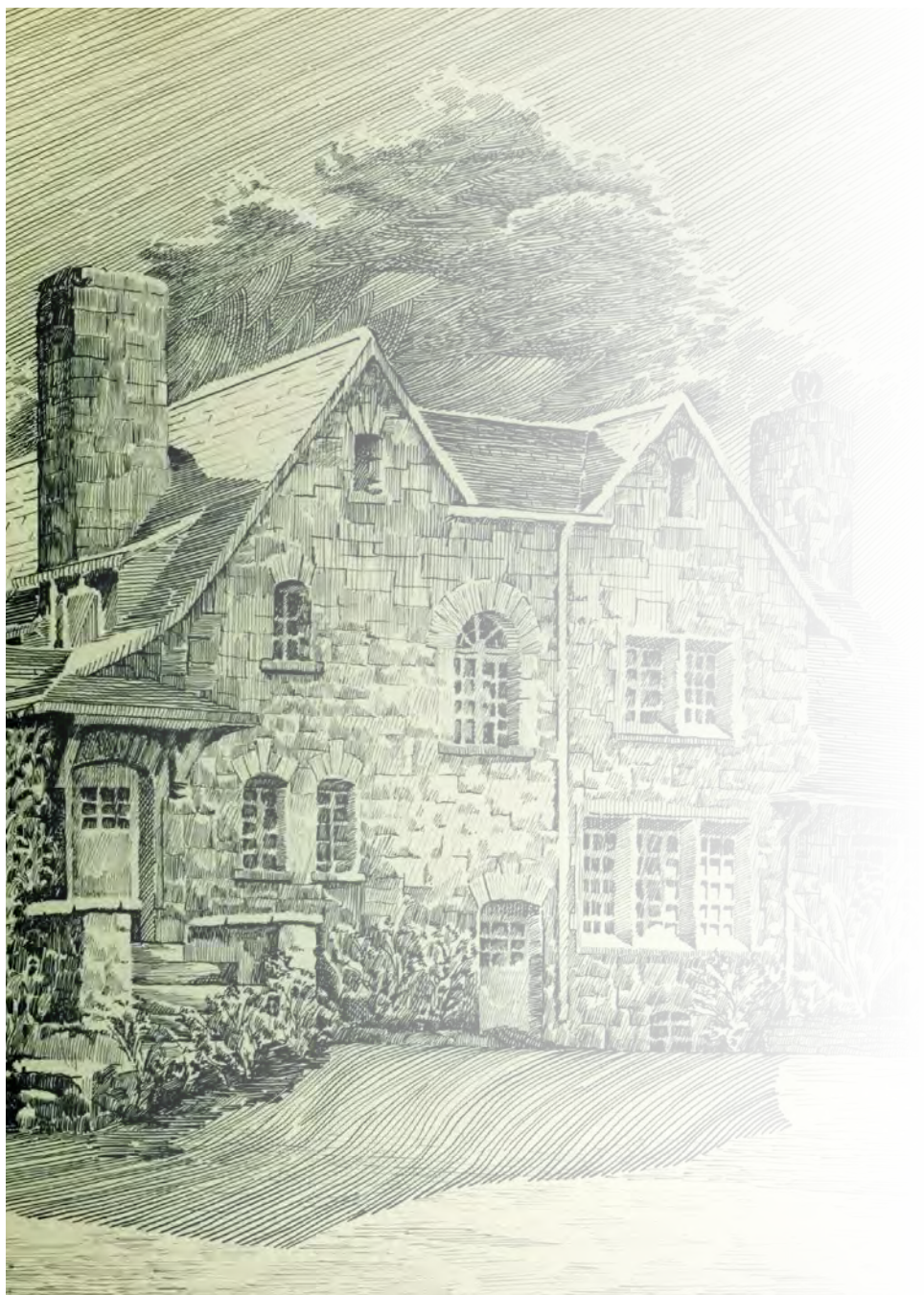

041

University Club

Alternate Names

Dean of Agriculture Residence
Grey Gables
Faculty Club

Architect(s)

David R. Brown and Hugh Vallance, Brown and Vallance Architects, Montreal

Builders

Built by university employees with the assistance of day labourers

Construction Dates

1913

Recognition

University of Saskatchewan 'B' Listed

1. Statement of Significance

The University Club was originally built as the Residence of the Dean of Agriculture. It was completed in 1912 at a cost of \$20,742 and was among the first buildings constructed on campus. Its status as an early priority for the university reflects the importance of the College of Agriculture to the institution. The University of Saskatchewan was the first in Canada to incorporate an agricultural college as an integral component. The house was initially occupied by William Rutherford, the first Dean of Agriculture. The building's current use as a club derives from its previous function as a venue for receptions and entertaining. The residence was vacated in 1961 in order for it to become home to the Faculty Club.



Figure 1. Sandstone window surround set into a field of greystone.



Figure 2. The Dean of Agriculture Residence (now the University Club), as it appeared before 1925. The MacKinnon Building is visible in the background to the left. Photo A-413, retrieved from http://scaa.usask.ca/gallery/uofs_buildings/

Although originally planned as a wooden building, the University Club was ultimately constructed in 'greystone' to match the rest of the campus. Other shared features are its arched door and window openings, and the human scale and form of the building. Although many features have been changed, the building maintains a degree of heritage value due to its age and association with the history of agricultural education at the University of Saskatchewan. The building was extensively renovated in 1966. In September 1972 the building suffered a fire and underwent further renovations in 1975. The fire did not do catastrophic damage to the building; however, the renovations removed many of the original interior finishes. The portions that were added in during alterations are beyond the scope of this document.

Note: The University Club is configured with floors numbered Basement, Ground Floor and First Floor. This report follows the same convention.

2. Character - Defining Elements

2.1 Materials

The primary exterior material of the University Club is rough-faced greystone, a form of dolomitic limestone local to the area around Saskatoon. Greystone is an important material with respect to the University of Saskatchewan as it was gathered from lands surrounding the site and defines many other buildings on the main campus. Window surrounds are fashioned from both greystone and sandstone (Figure). (See ['Appendix: Stone'](#) for further information on stone materials used at the U of S). Stucco has been added as an exterior material in more recent renovations. The roof was originally finished in slate tile, but is now clad in asphalt shingles. Exposed wooden rafter ends were formerly visible beneath the eaves, but have since been covered by a stucco soffit. Wooden window frames have been preserved in a number of locations. However, extensive renovations have removed or replaced many of the original windows.



Figure 3. A greystone wall which now forms part of a basement meeting room.



Figure 4. An elevator shaft and the deletion of several windows have greatly changed the eastern facade.



Figure 5. L to R: The addition to the western facade, the enclosed porch.

The interior of the building has been altered to a great degree, and much of the commemorative integrity of the original interior is lost. A greystone wall in the building's basement shown in Figure 3 has been well maintained and integrated into the building's new use.

On the ground floor, a former porch has been made into an enclosed corridor, such that the greystone wall of the original front elevation is now an interior feature. In this case, the material exists in a good state of commemorative integrity. The only other original materials on the ground floor are the windows, most of which retain their original wooden frames, single glazed lites and original hinges and clasps. The windows on the first floor are in similar condition.

The floor finishes throughout the University Club have been changed since its days as a residence and no longer hold any commemorative integrity. The original flooring may however still exist under the carpet and tile added by later renovations.

2.2 Form

The University Club has a very human scale of two storeys above ground. Its original footprint has been expanded to more than double that of the original. The additions remain low in scale with heights below that of the original form. The south and east elevations have been maintained; however, the expansions to the north and west have compromised the integrity of the original form. An elevator shaft, visible in Figure 4, has been appended to the east side and the south facing porch has been enclosed. Figure 5 shows the addition to the west of the building and the enclosed porch on the south side. Figure 6 shows the original building with its open porch. The numerous additions to this building have partially obscured the heritage value of its original form.



Figure 6. Original southern facade of the University Club featured slate tiles, dormer windows, arches, bay windows and an outdoor porch. Retrieved from Facilities Management Division Asset Record System, File FC-4-T.

2.3 Style

The style of the University Club is Arts & Crafts, a domestic style of architecture of the latter half of the 19th century affiliated with the Victorian Gothic revival. The Arts & Crafts movement favoured traditional forms of craftsmanship, simple forms, manual production techniques and decorative motifs recalling mediaeval art. The style shares many characteristics with the Collegiate Gothic used elsewhere at the university; however, the University Club was detailed with a more residential palette of forms, including arched openings, dormer and bay windows. Figure 6 shows a drawing of the primary façade, featuring these elements.

Slate tiles, a character-defining material of many early University of Saskatchewan buildings, have recently been replaced by asphalt shingles. The exterior of the building originally featured two dormer windows punctuating the roofline on the south elevation. With renovations in the 1960's and 1970's these dormers were replaced by a single large dormer forming a first floor addition (Figure 7). A dormer window was also removed from the east roof. Figure 4 shows the current eastern facade. Figure 8 shows the original configuration of the east and west facades.



Figure 7. Alteration to former dormer windows.

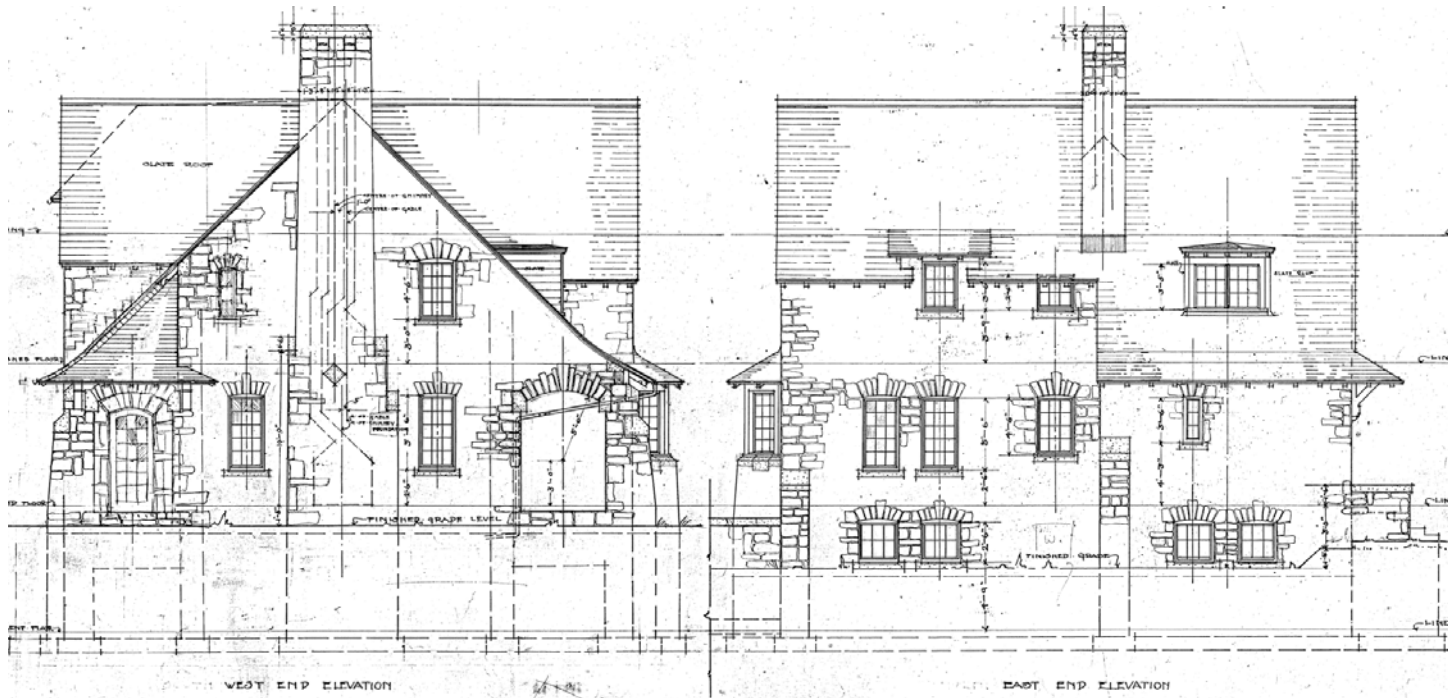

Figure 8. L to R: The west and east facades as they were originally designed. The east facade has since lost several of its windows to renovations. No windows or doors have survived on the west facade. Retrieved from Facilities Management Division Asset Record System, File F-6-T.

Some windows have been replaced while others have been altered in form and function. For example, some exterior windows on the ground floor now form part of an interior corridor and have been modified to become display niches. The windows still feature the arches that are a characteristic of the Arts & Crafts style, and are recognizable as elements of the original exterior wall.



Figure 9. A diamond cut detail on the elevator shaft.

The bay window on the building's south side has been converted into an entrance. The form of the bay is still intact; however, the central window has been replaced with a door. The exterior of the building has maintained much more of its character definition than the interior, although major renovations have been made. The building features greystone quoins along its corners; a character-defining element of the Arts & Crafts style. On the east façade, a few windows in arched greystone openings exist in a good state of commemorative integrity. A few have been deleted due to the addition of the elevator shaft. On the north elevation, most windows have been removed or filled in by greystone or wood siding. The arch of a large original window is still visible in the stonework despite being filled in. Another smaller arched window is now an exhaust duct, but its keystone and arched shape are still discernible.

The west elevation has been greatly changed as it now faces into the interior dining space. The windows and doors no longer exist. Originally, this façade featured a greystone chimney with diamond shaped decorations cut into the stone. The form of the chimney is still visible, but the only other remaining element of this facade is the arched porch. Figure 8 shows the original west elevation with the chimney detail. The elevator shaft, which was added in a later renovation, pays tribute to the diamond cutouts as shown in Figure 9.

2.4 Location

The location of the University Club, shown in Figure 10, reflects its history as a residence for the Dean of Agriculture. The home was located so as to be near the University Farm and allow the Dean of Agriculture good access to the barns and paddocks. The University Club also exists in close proximity to the [MacKinnon Building](#) as this building was originally intended to become the College of Agriculture building. The proximity of the University Club to the agricultural buildings is thus a character-defining element.

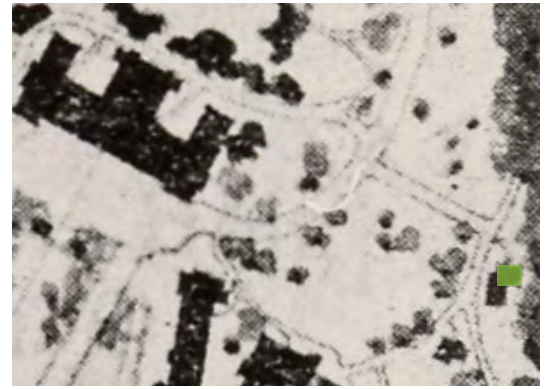
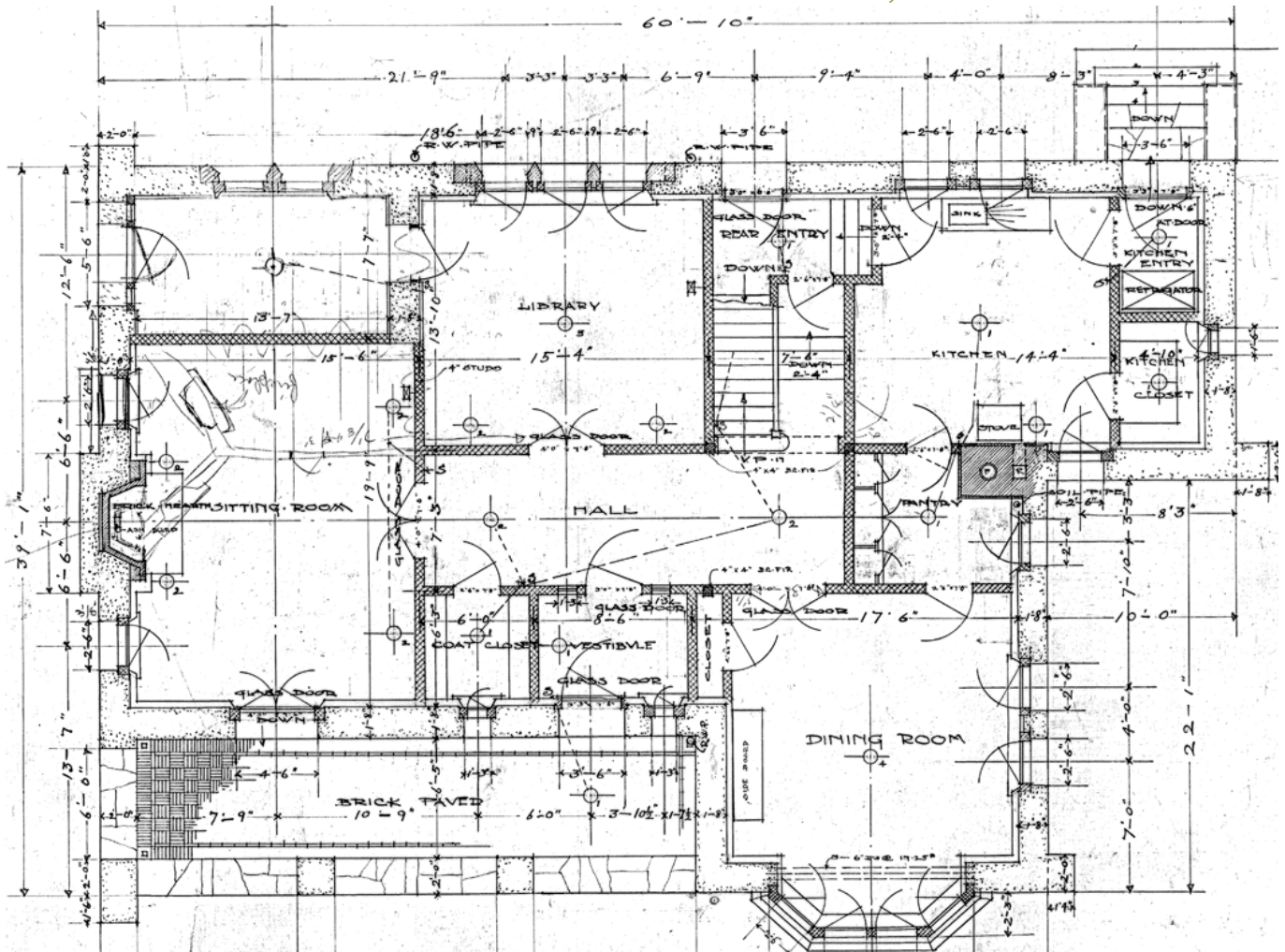

Figure 10. The location of the University Club is indicated in green on the original 1909 Campus Plan. The plan is oriented with North to the left. The MacKinnon Building is located in the upper left corner of the plan.

Figure 11. The original ground floor plan of the University Club when it was being used as a residence. Retrieved from Facilities Management Division Asset Record System, File FC-2-T.



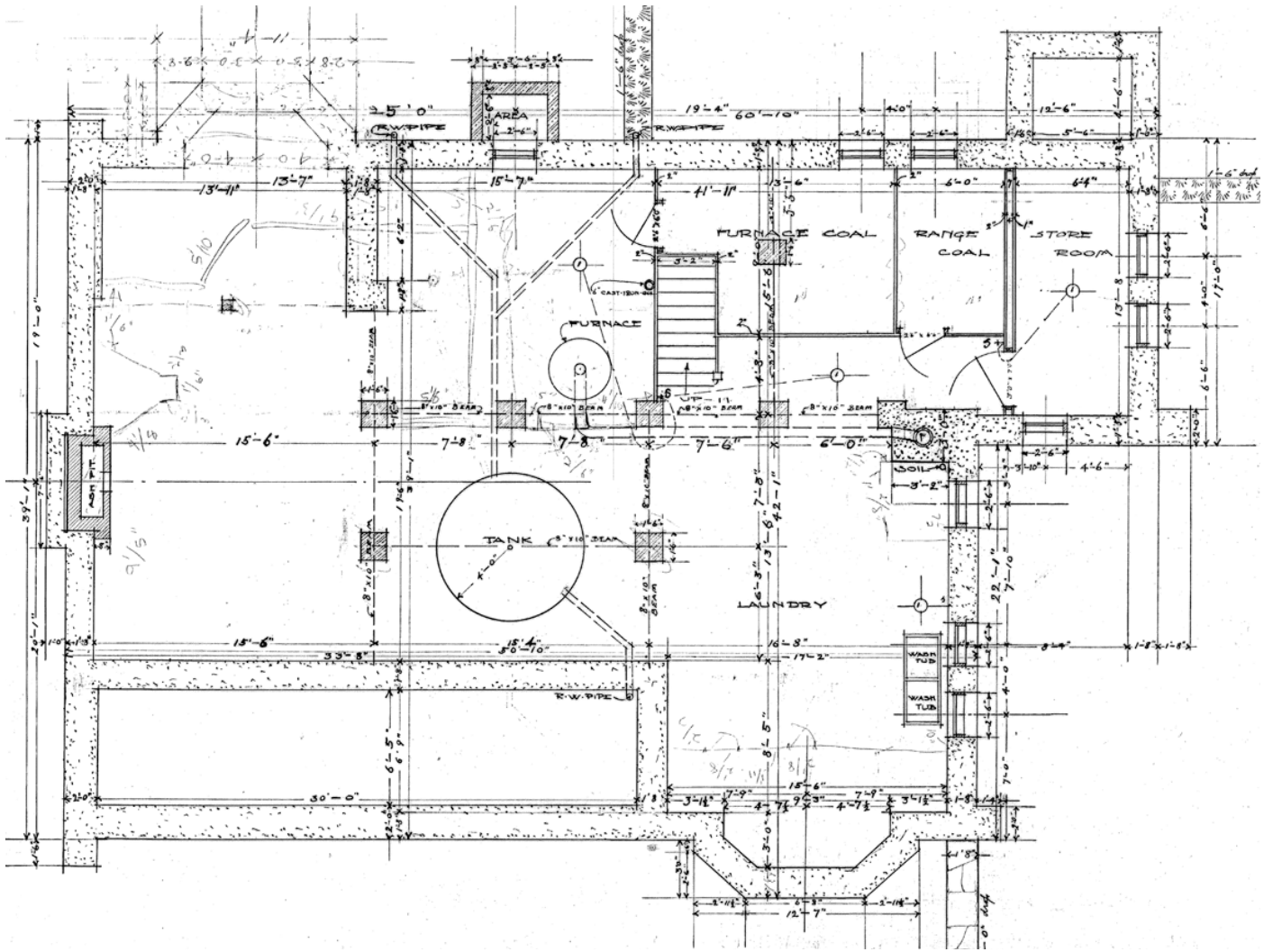

Figure 12. The original basement floor plan. Retrieved from Facilities Management Division Asset Record System, File FC-1-T.

2.5 Spatial Configuration

The spatial configuration of this building has changed considerably with its transition from private residence to a club. The interior initially consisted of a closed floor plan characterized by individual and distinct rooms accessed by hallways. Figure 11 shows the original ground floor. With renovations, the interior has become a series of much larger and more open spaces. The footprint has been greatly expanded by additions. Access has been increased by the addition of another stairwell and an elevator. The result is greater circulation through the original building. As previously discussed, numerous windows and doorways have been removed to accommodate renovations.

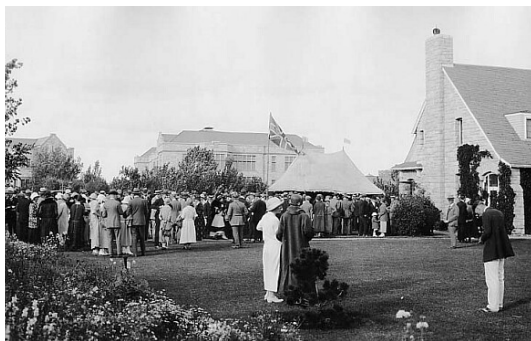

Figure 13. The Association for the Advancement of Science gathers at the Residence of the Dean of Agriculture, August 22, 1924. Photo A-1361, retrieved from http://scaa.sk.ca/gallery/uofs_buildings/

2.6 Systems

The University Club has load bearing exterior stone walls supporting wooden floor joists and roof rafters. The basement walls are also constructed of stone, and are supported on concrete footings. Two rows of wooden posts and beams in the basement support the ground floor joists at their midspan (Figure 12). On the ground floor, this function is served by wooden stud walls.

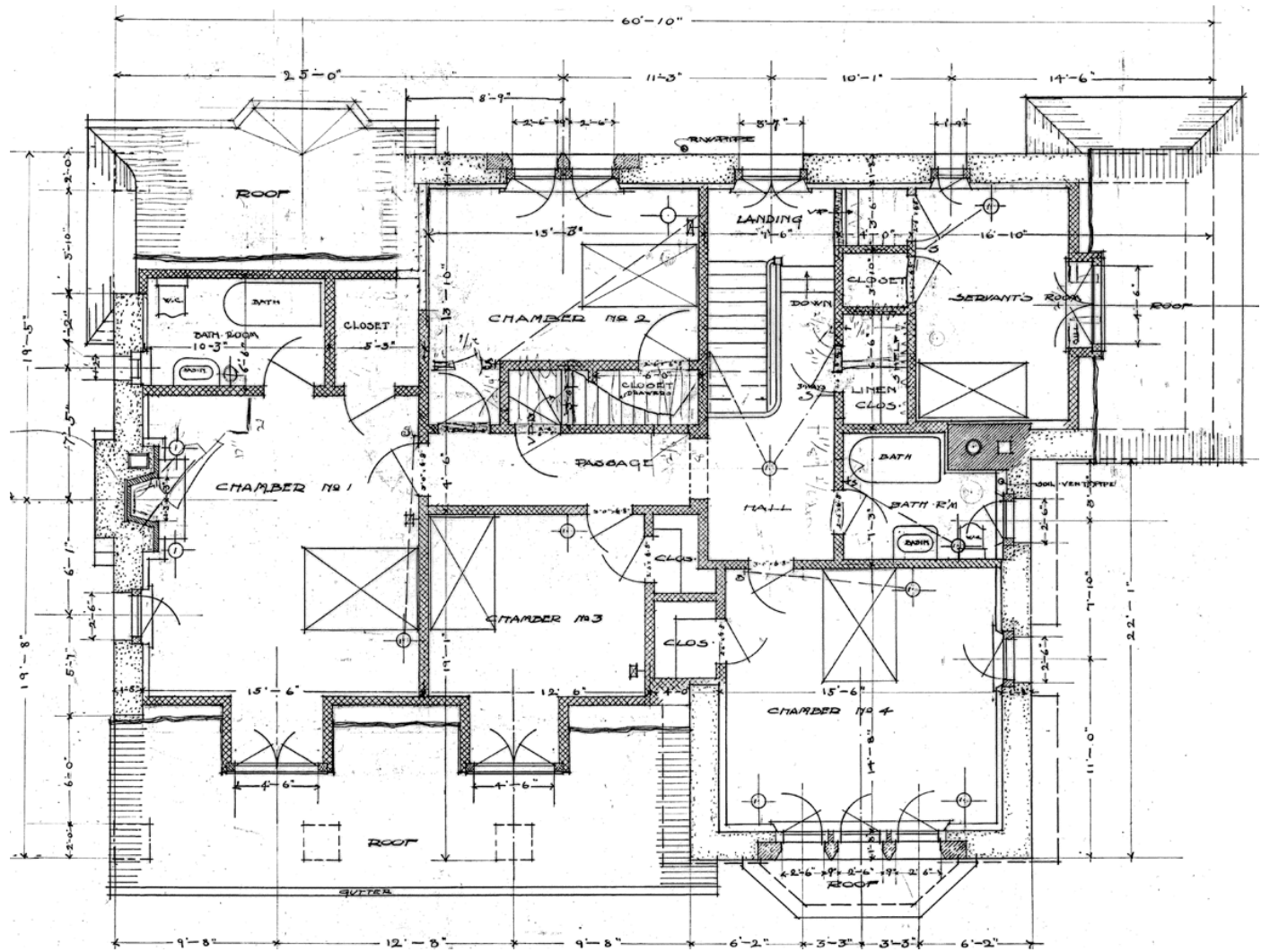

Figure 14. The first floor plan of the University Club as a residence for the Dean of Agriculture. Retrieved from Facilities Management Division Asset Record System, File FC-4-T.

2.7 Use(s)

This building served as a residence for the University's Deans of Agriculture from its construction until 1961. Since 1961, the building has served as a Faculty Club, first for members of the Faculty Club and then evolving to become inclusive of others members of the university community. Membership was open to non-faculty for many years before the club was renamed in 2012 to coincide with its 50th anniversary year. As Figure 13 attests, the Dean's Residence was often host to outdoor receptions and events. The building's use as a club is therefore generally consistent with its original purpose and the building form is well suited to this new function; however, the uses of individual rooms and spaces has changed considerably.

Originally the building's ground floor had multiple residential uses. These are indicated in the floor plan (Figure 11), and include a library, kitchen, dining room, sitting room, vestibule, pantry and several closets. The majority of the original ground floor area is now used as a kitchen and as circulation space. The additions are used as dining areas.



Figure 15. William Rutherford (as Dean) addressing Agricultural Society Convention in the University of Saskatchewan Livestock Pavilion, ca. 1920's. Photo A-1335, retrieved from http://esask.uregina.ca/entry/rutherford_william_john_1868-_1930.html

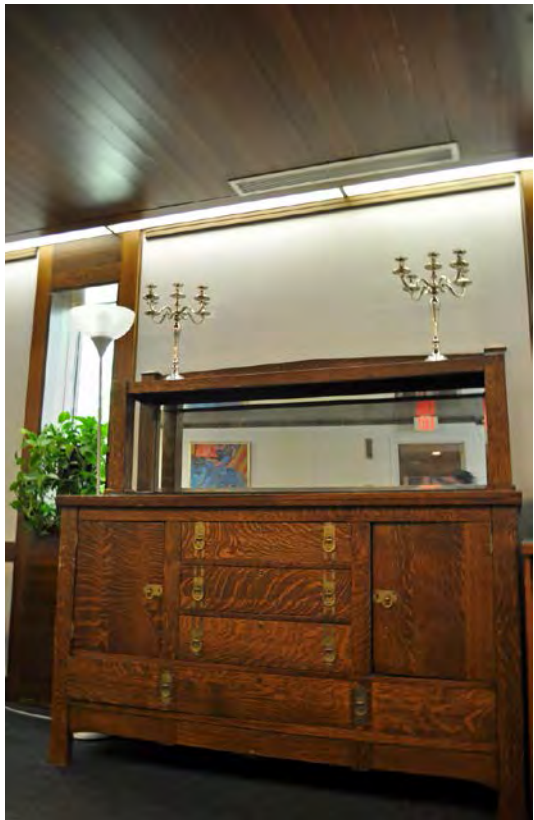

Figure 16. A cabinet of unknown origins inside the University Club.

The upper floor of the Dean of Agriculture Residence formerly housed four bedrooms, two restrooms, and servants' quarters. The first floor plan (Figure 14) indicates these uses. The first floor now features a large event room complete with a bar. The basement, formerly a service area, is now used as a series of meetings rooms.

2.8 Cultural & Chronological Associations

The University Club building can broadly be associated with agriculture at the University of Saskatchewan. The house was built to be part of the University Farm with proximity both to the [Stone Barn](#) and to the [MacKinnon Building](#). The purpose of the house was driven by the university's incorporation of an agricultural college. Culturally, the University Club represents the importance placed on the study and practice of agriculture by the University of Saskatchewan in its early years.

The University Club is also associated with its first resident, Dean William Rutherford. Rutherford was the University of Saskatchewan's first Dean of Agriculture and Saskatchewan's first agricultural scientist. The original drawings for the building were labeled 'Rutherford Residence'. Rutherford lived in the building from its completion in 1913 until his unexpected death in 1930. Prior to joining the university, Rutherford had been Deputy Minister of Agriculture and had endorsed the idea that a College of Agriculture should become an integral part of the university – an idea unique in Canada at the time. In 1909 Rutherford left the civil service to become a member of faculty at the newly established university. He is credited with having created the College of Agriculture and with having significantly shaped the agricultural policies of the Province of Saskatchewan. He was posthumously inducted into the Canadian Agriculture Hall of Fame in 1966 and the Saskatchewan Agriculture Hall of Fame in 1972.

The University Club can be associated with its former namesake: the institution of the Faculty Club. As a social organisation, the Faculty Club existed long before a building was assigned to it. The Faculty Club first met in room 143 of the [MacKinnon Building](#) on December 9, 1927. A Faculty Club building was first discussed on November 2, 1928. Consideration was given to locating the club in the Arts Building that was being planned at the time. A committee with the purpose of erecting a building for the club was formed by motion of the university's first president, Dr. Walter Murray. The committee's efforts were cut short by the Great Depression. In the 1940's the Faculty Club again pursued the idea of a 'Faculty Club House.' Accommodations in the planned [Memorial Union Building](#) were pursued and then dismissed. The Faculty Club finally gained a formal home in 1961 when the Dean of Agriculture's Residence was offered. The building was renamed the Faculty Club and was known by that name for over 50 years.

The Faculty Club saw a steady decline in membership in the 1970's and evolved in response, to become more inclusive. Membership in the Faculty Club is now open to anyone. The University of Saskatchewan Archives does not have records of Faculty Club meetings after 1978.

3. Associated Objects

A wooden cabinet (Figure 15) with a mirrored backing has unknown origins. The cabinet may be associated with the University Club or one of the previous families who resided in the house when it was the residence of the Dean of Agriculture.

4. Supporting Documents

Bell, M.J. (1996). *Hoofprints to Reprints: The History of Animal Husbandry, Animal Science and Animal and Poultry Science, University of Saskatchewan 1909-1989*. Saskatoon: University of Saskatchewan.

Facilities Management Division (2011). Asset Resource Database [Data File]. Retrieved from \\usask\fmddfs\files\iis\IIS_Public\ARS

Kerr, D. (2012). *University of Saskatchewan Faculty Club: The Story*. Saskatoon: University of Saskatchewan.

Lewry, M. (Retrieved 2011). *The encyclopedia of Saskatchewan, Rutherford, William John*. Retrieved from http://esask.uregina.ca/entry/rutherford_william_john_1868-1930.html

University of Saskatchewan Archives. (Retrieved 2011). *Campus Buildings: Faculty Club*. Retrieved from http://scaa.sk.ca/gallery/uofs_buildings/.

University of Saskatchewan Archives. (Retrieved 2011). *Events in the History of the University of Saskatchewan 1930: William Rutherford First Dean of Agriculture*. Retrieved from http://scaa.usask.ca/gallery/uofs_events/articles/1930.php





5. Summary of Character - Defining Elements

Materials

- greystone walls
- wooden window frames
- sandstone trim
- exposed wooden rafter ends

Form

- domestic scale

Style

- elements associated with the Arts & Crafts style
- gabled roofs
- arched openings
- dormer and bay windows
- quoins
- diamond details

Location

- original to 1909 campus plan
- proximity to University Farm

Spatial Configuration

- former porch (now enclosed)

Structural Systems

- stone walls

Use(s)

- residence for Dean of Agriculture
- entertaining and receptions
- faculty club

Cultural & Chronological Associations

- agriculture at the University of Saskatchewan
- Dean William Rutherford

048

Dental Clinic



048

Dental Clinic

Alternate Names
College of Dentistry

Architect(s)
J. Holliday Scott, M. Desmond Paine and Ted Rusick J. Holliday Scott and M. Desmond Paine Architects, Saskatoon

Builders
Poole Construction

Construction Dates
1978-1979

Recognition
University of Saskatchewan 'B' Listed

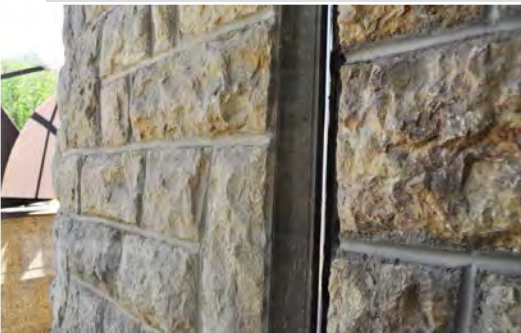

Figure 1. Exterior and interior greystone separated by glass.



Figure 2. Top to bottom: Tyndall stone with punched windows, concrete waffle slab and glazed curtain wall.

1. Statement of Significance

Designed by the firm Holliday-Scott Paine Architects, the Dental Clinic has been the home of the College of Dentistry since 1979. Its principle designer, John Holliday-Scott, was a particularly talented architect who adapted the modernist sensibility of his time to the context and historical traditions of the University, in a characteristically inventive way. In this and other buildings such as the Law-Commerce complex and the Lutheran Seminary, Holliday-Scott re-framed the familiar materials of the campus and re-interpreted the traditions of the Collegiate Gothic style. The Dentistry Building has heritage significance as a particularly successful and highly original example of late Modern architecture.

Note: The Dental Clinic is configured with floors numbered Basement, First Floor, Second Floor, Third Floor. This report follows the same convention.

2. Character - Defining Elements

2.1 Materials

The exterior of the dental clinic is a modernist composition mixing the traditional materials of the University of Saskatchewan campus with contemporary materials. Rough-faced 'greystone' (Figure 1) is used to form a base for the building and encloses the basement and ground floor. Cut Tyndall stone is used as a cladding material for the third floor (Figure 2). The second floor is enclosed in a glazed curtain wall, such that the Tyndall stone volume of the third floor appears to float above the heavier greystone base (Figure 2). These three primary exterior materials – greystone, Tyndall stone and glass – and the expressive manner in which they are deployed, are character-defining elements. The main entrance is accessed across a bridge made of cast-in-place concrete, with an exposed-aggregate finish (Figure 3). This material is also used on the interior.

(For further information on building stones used at the U of S, refer to ['Appendix: Stone.'](#))



Figure 3. Exposed aggregate concrete.



Figure 8. The Dental Clinic. Photo retrieved from Flaman, B. (2013), *Architecture of Saskatchewan: A Visual Journey, 1930-2011*.



Figure 4. Red ceramic tile flooring.



Figure 5. The effect of the patterned flooring is visible in this 1979 photograph of the dental clinic. Photo A-8651 retrieved from <http://sain.scaa.sk.ca/items/index.php>

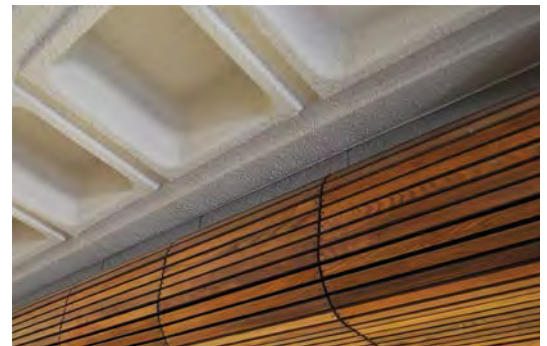

Figure 6. Exposed concrete waffle slab, oak ceiling bulkhead.



Figure 7. Exposed ribbed concrete block.



Figure 9. Douglas Fir partitions in Student Clinic.

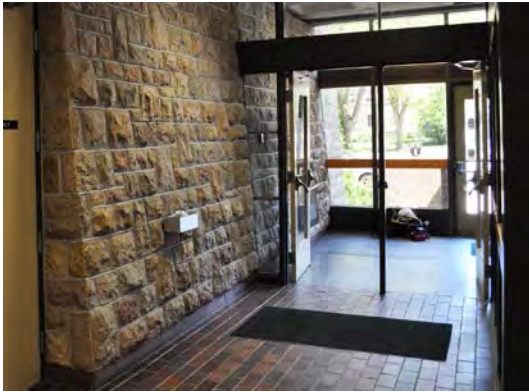

Figure 10. Canted greystone wall at the main entrance.



Figure 11. Archer style windows.

The exterior materials are also used extensively on the interior of the building. The greystone walls of the ground floor wrap around and continue into the interior of the building at a glazed entrance vestibule (Figure 1). Floors in the ground floor lobby are red terra cotta tile (Figure 4). The floor of the dental clinic was originally patterned to relate the small scale of the individual work spaces to the large scale of the clinic, but has since been replaced (Figure 5). The ceiling in the lobby is an exposed concrete waffle slab. The underside of the structural floor slab is expressed as a feature in several other locations. Figures 2 and 6 show examples of the waffle slab exposed on the exterior and the interior respectively. A system of oak ceilings and bulkheads are used to conceal services (Figure 6). Oak is also used for some doors and window sills. Douglas Fir makes up the partitions between dental chairs on the second floor. Walls are composed of exposed-aggregate concrete or a ribbed concrete block (Figure 7). Oak, concrete and concrete block are character-defining materials.

Architect John Holliday-Scott often specified accent colours in his work. In the case of the Dental Clinic, the colour red was used to bring warmth to the architecture. The colour, most notably appearing above the central stainless steel stair (Figure 16), is a character-defining element.



Figure 12. Cylindrical volume of the dispensary..

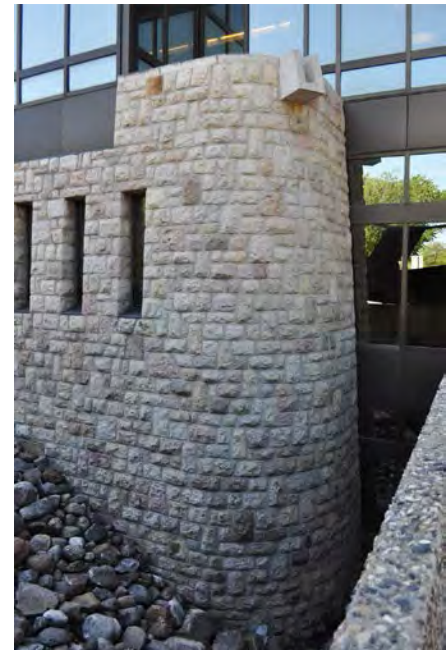

Figure 13. Rounded wall, recalling a castle turret.

2.2 Form & Style

In the Dental Clinic, John Holliday-Scott produced a work of architecture that exploits the full expressive possibilities of its materials, and manages to be of its time but also historically aware. The exterior form and expression of the building takes the familiar palette of materials traditionally used at the University of Saskatchewan, but re-frames them in new ways. Here, for example, rough-faced greystone is not used over the full height of the exterior walls, but to define a heavy base as a distinct element. Although used traditionally for trim and decoration, Tyndall stone is used here as a primary material, distinguishing the third floor as a volume separate from the other parts of the composition. Glazing is used not only for discreet window openings, but also as a visual separation between solid elements of the composition. This expressive use of materials is thoroughly modern in its impulse, but in other ways, the building alludes to the past.

The heavy stone base makes reference to the mediaeval castle in its form and detailing. Its corners are rounded like a turret and its walls are canted. Narrow windows allude to archery slots (Figure 11). The main entrance is reached by a bridge across a deep pit, like a drawbridge over a moat (Figure 14). Projecting concrete scuppers refer to earlier gothic precedents. Historical forms, like traditional materials, are re-imagined in a contemporary way.

The ways in which materials intersect and connect to one another is characteristically modern. The glazed wall of the entrance vestibule connects lightly to the stone walls, giving the impression that the stone wall passes through the glass, into the interior. The extension of material planes 'through each other' in this manner is a character-defining element.

Structural elements are used to particular expressive effect in the Dental Clinic. On the second storey, concrete columns are left bare as shown in Figure 15, and are finished to expose their stone aggregate. On all floors, portions of concrete waffle slabs are revealed. The central stair leading from the entrance lobby up to the Student Clinic on the second floor is designed such that its stainless steel handrails form its structure, and treads are suspended by their balusters. The effect is that the treads appear to float, without obvious means of support (Figure 16). Exposed and expressed structural systems are character-defining elements of the Dental Clinic.



Figure 14. Bridge at main entrance.



Figure 15. Concrete columns with exposed aggregate finish.



Figure 16. Central stair.



Figure 18. Stair detail.

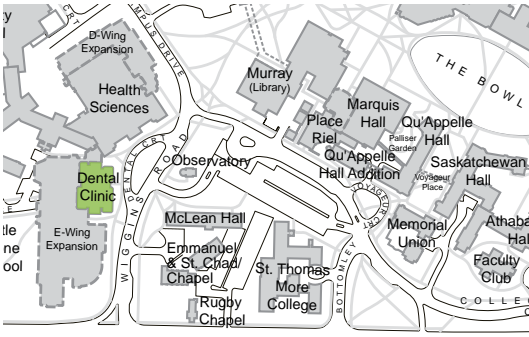

Figure 19. The location of the Dental Clinic is indicated in green on this contemporary campus plan.



Figure 20. Cylindrical volume of the dispensary.



Figure 21. Projecting bays.

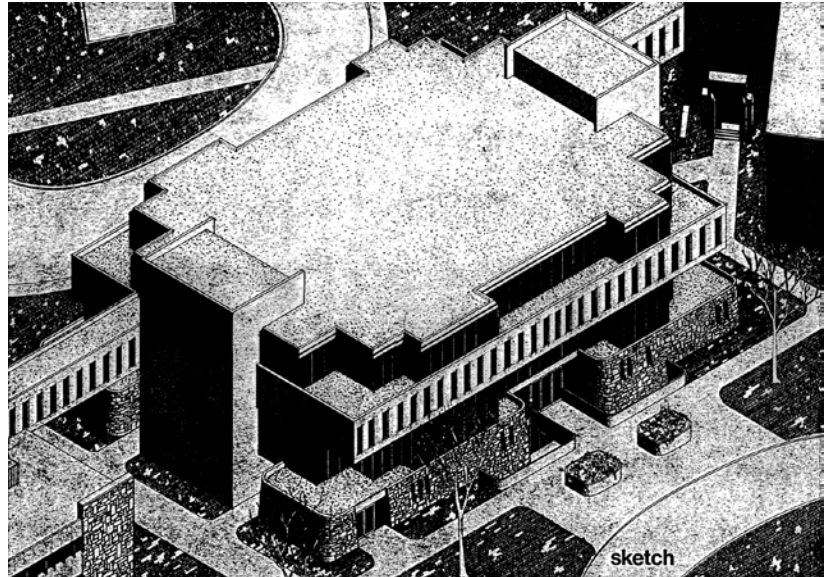

Figure 17. Preliminary sketch including a proposed fourth floor. Retrieved from Facilities Management Division Asset Record System, File DC-63-C.

At three storeys in height, and with a relatively small footprint, the Dental Clinic has a scale in keeping with the rest of the campus. It is somewhat lower than its neighbor, the old [Health Sciences Building](#), which varies from four to five storeys in height. The design of the Dental Clinic was also intended to accommodate a fourth floor at some point in the future (Figure 17). Recently, the Academic Health Sciences E-Wing addition has been joined to the Dental Clinic, so that it is no longer a discreet object, but is now part of a larger complex. However, the addition has been designed to allow the original form of the building to remain legible.

2.3 Location

The Dental Clinic is located immediately south of the [Health Sciences 'A Wing'](#) on the west side of the Wiggins Avenue entrance to the University of Saskatchewan. Figure 19 illustrates the location of the building. The Dental Clinic can be considered a part of the medical precinct of buildings at the University of Saskatchewan. With the construction of the Academic Health Sciences E-Wing, it now forms part of a complex of medical buildings. Its grouping with other medical buildings such as the Health Sciences Buildings and Royal University Hospital is a character-defining element.

2.4 Spatial Configuration

A signature feature of John Holliday-Scott's architecture was the creation of a dramatic central space, around which the building is organised. In the Dental Clinic, the second floor Student Clinic is the central space forming the heart of the building. In the Student Clinic, dental students practice their craft, in an open plan layout of cubicles arranged in a grid, each containing a dentists' chair and equipment (Figure 23). At the centre of the grid is a reception desk and dispensary, with support functions contained within a circular room expressed as an oak-clad cylinder (Figure 20). The clinic is a soaring double-height space, overlooked by the corridor and faculty offices of the third floor. Various rooms on the third floor are expressed as bays, projecting into the upper space of the Clinic (Figure 21). A large piece of artwork, mounted in the south wall of the clinic, is an integral part of the space and a character-defining element. See also Section 3 - Associated Objects.

The Student Clinic is accessed via a large open stairwell placed at the centre of the ground floor plan directly visible upon entry into the building. Secondary access is provided by an elevator and fire stairs at the north and south ends of the building. The central staircase between the first and second floors is a character-defining element (Figure 16).



Figure 22. View from basement window.

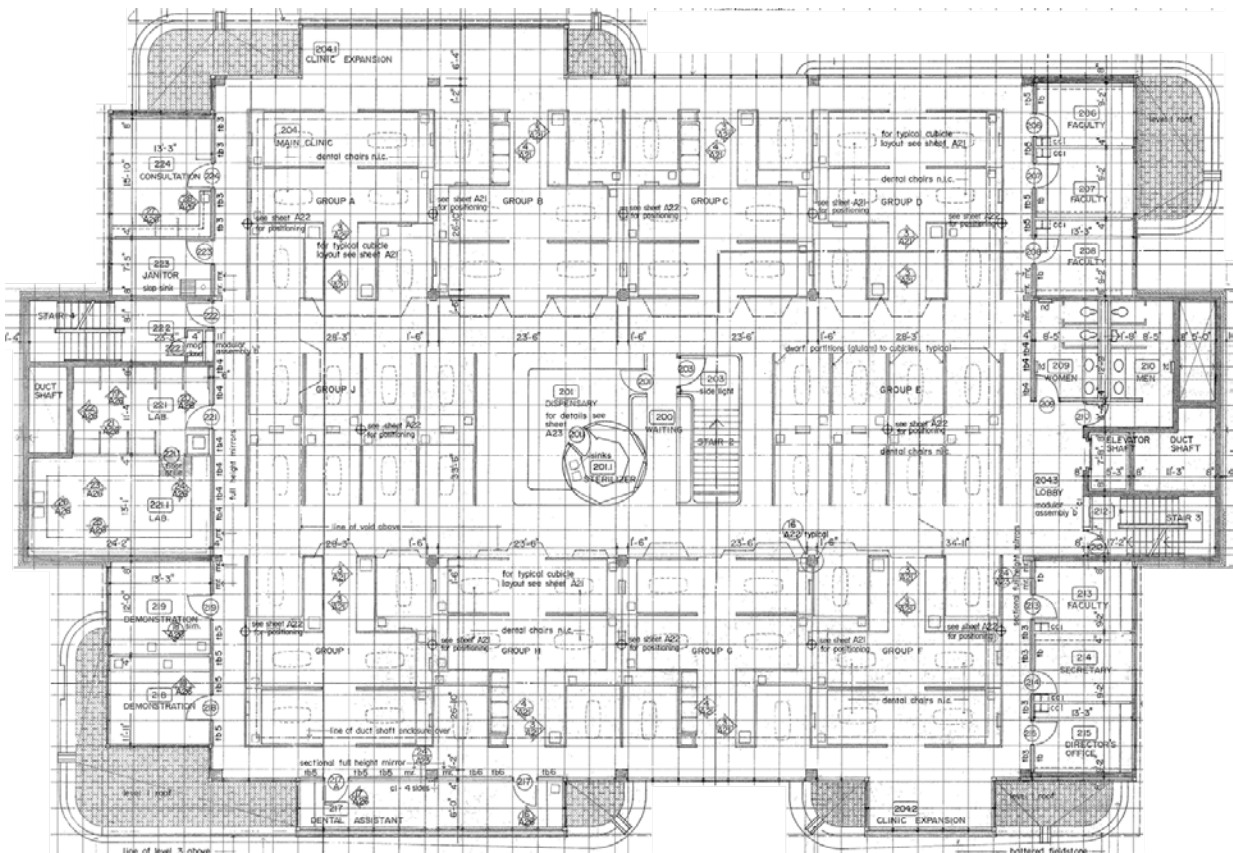

Figure 23. Second floor plan. Retrieved from Facilities Management Division Asset Record System, File DC-377-C.

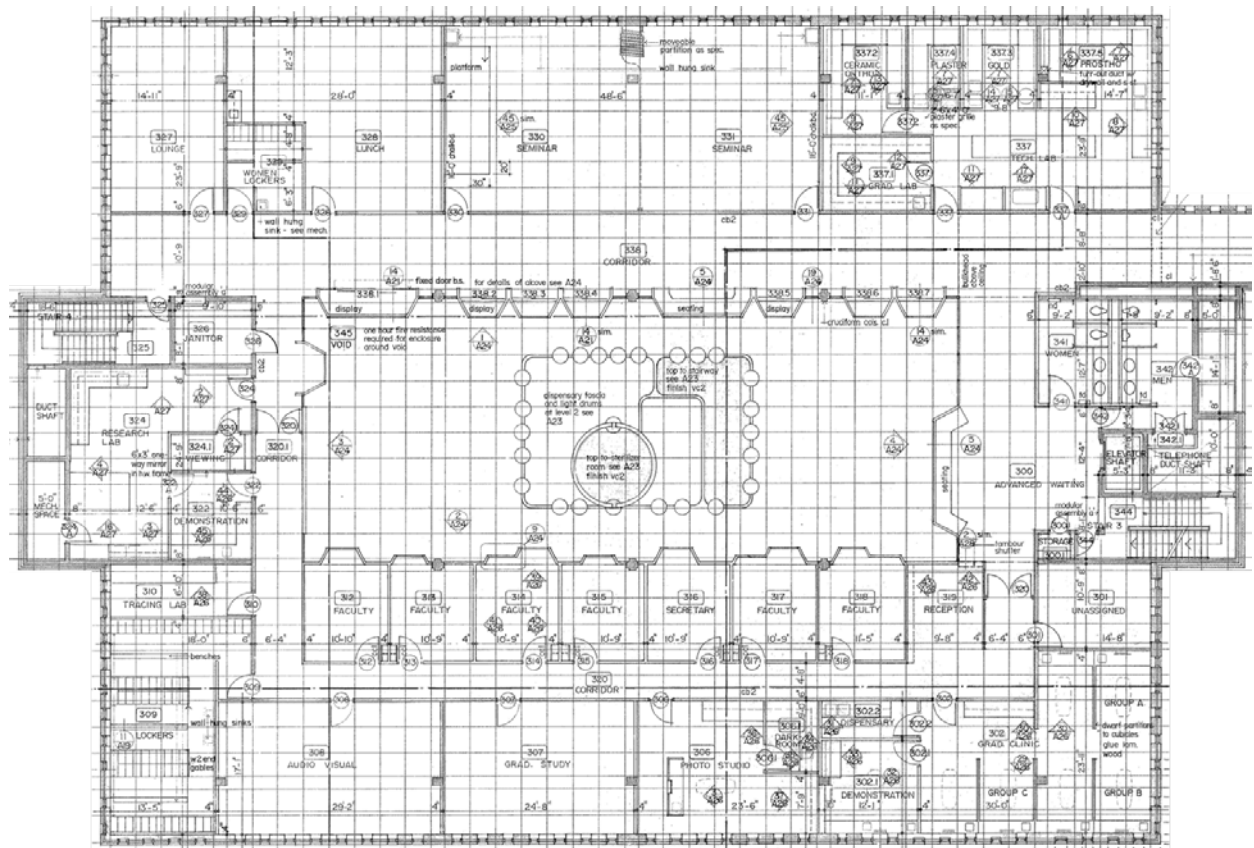

Figure 24. Third floor plan. Retrieved from Facilities Management Division Asset Record System, File DC-376-C.



Figure 25. The main Student Clinic in use, January 1979. Photo A-6548 retrieved from http://scaa.sk.ca/gallery/uofs_buildings/

The basement is accessed by a wide staircase in the entrance vestibule. The basement consists of large enclosed rooms used for stores and mechanical equipment. At the foot of the wide staircase natural daylight penetrates the floor through a glazed wall that looks out into the excavated area under the entrance bridge.

The ground floor of the building is divided into reception and waiting room space and patient care rooms for the Faculty Clinic. The third floor is organised around a corridor overlooking the space of the Student Clinic on the floor below. Offices and seminar rooms and laboratories are arranged in a ring around the upper portion of the Student Clinic space (Figure 24). The third floor corridor also features a series of bays that accommodate seating and display cabinets.

2.5 Systems

The Dental Clinic was constructed with a cast-in-place concrete structural frame and concrete waffle floor slabs. In areas where an open plan spatial configuration was used, the concrete columns were left exposed, with an exposed aggregate finish (Figure 15). The expression of structural elements such as concrete columns and waffle slabs are character-defining elements. See Section 2.2 Form & Style.

2.6 Use(s)

The establishment of the College of Dentistry was approved in March of 1965, making it the ninth dental school in Canada. The first students were admitted to the program in 1968 but construction of a building did not begin until 1978. Since its opening, the Dental Clinic has been used by the College of Dentistry for education and practice. The ground floor houses a Faculty Practice Clinic as well as administrative offices. The second floor is entirely occupied by the 64 chair Student Treatment Clinic. Here students perform dental work on patients to fulfill the clinical requirements of their program (Figure 25). The third floor consists of offices, classrooms, laboratories and lounges. The Dental Clinic is still used for the purpose for which it was built and has been altered relatively little. The use of the building for dental education and practice is a character-defining element.

2.7 Cultural & Chronological Associations

The Dental Clinic can be associated with its designer, architect John Holliday-Scott of the firm Holliday-Scott Paine. Holliday-Scott was born in the UK, and immigrated to Canada in 1957 after receiving his architecture degree from Kingston College of Art. In the UK he worked with the firm Chamberlin, Powell and Bon whom he respected for their ability to integrate historical context into contemporary architecture. In Canada, Holliday-Scott first worked with the Saskatoon Firm Kerr and Cullingworth for two years before starting his own firm. His first building for the University of Saskatchewan was the dining hall at Emma Lake, Kenderdine Campus. Holliday-Scott was also the architect for the [Law Building](#) and the [Lutheran Seminary](#), both on the University of Saskatchewan campus.



Figure 26. Art work, by architect John Holliday-Scott, in student clinic.



Figure 27. Collection of historical dental artifacts.



Figure 28. Pedal powered X- Ray unit.

3. Associated Objects

Mounted on the upper south wall of the clinic is a large piece of artwork that is original to the building (Figure 26). This work was designed by architect John Holliday-Scott as part of the building project, and is integral to the architecture of the space.

The third floor houses numerous objects significant due to their age and their relation to the practice of dentistry (Figure 27). These dental items include a gold crown from the late 1800's, numerous model sets of teeth, several photographs and a full X-Ray unit that was operated by foot pump (Figure 28).

In the basement are more objects that have not been displayed including a full dental cabinet made of marble and oak with instruments, medicines and surgical tools, and early X-Ray equipment. Some of these artifacts are dated as early as 1910.

4. Supporting Documents

College of Dentistry. (Retrieved 2012). *History of the College*. Retrieved from <http://www.usask.ca/dentistry/about/history.php?heading=menuAbout>

Facilities Management Division (2011). Asset Resource Database [Data File]. Retrieved from \\usask\fmddfs\files\iis\IIS_Public\ARS.

Kerr, D. (2011, Summer). John Holliday-Scott Designed U of S Law Building and Wascana Place. *Worth: Saskatchewan's Architectural Heritage Magazine*, 28 (2), 18-19.

McMahen, L. (September 5, 2009). Green Roof Study Underway on Dentistry Building. *On Campus News* 13(2). Retrieved from <http://news.usask.ca/archived/ocn/05-sep-09/news12.shtml>

University of Saskatchewan Archives. (Retrieved 2012). *Campus Buildings: Dental Clinic*. Retrieved from http://scaa.sk.ca/gallery/uofs_buildings/

Wolfson, D. (Wolfsun Productions). (2009). *Edifice & Us* [Season 2 Episode 1]. Buildings with a Heart: John Holliday-Scott's Buildings. Retrieved from <http://www.youtube.com/watch?v=14PAbvxCi4o>



5. Summary of Character - Defining Elements

Materials

- aluminum-framed glazing
- greystone walls
- tyndall stone cladding
- oak ceilings and millwork
- brick flooring
- concrete
- stainless steel stair
- red accent colour

Form & Style

- scale
- projections
- canted walls
- references to castle walls
- bridge
- flat roof
- scuppers
- archer style windows
- rounded corners, bulkheads, partitions
- bays
- stair details

Location

- medical precinct

Spatial Configuration

- central atrium
- view into atrium
- open plan Student Clinic
- main staircase
- associated artwork

Systems

- exposed concrete columns
- exposed concrete waffle slab

Uses

- dental education and practice

Cultural & Chronological Associations

- John Holliday-Scott

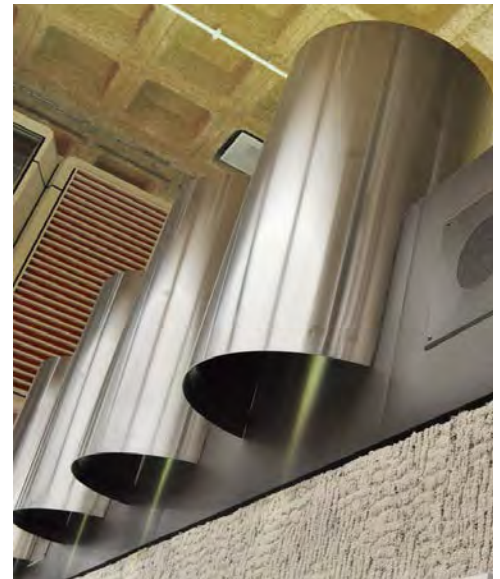

049

Health Sciences Building



049

Health Sciences Building

Alternate Names

Medical College

A Wing

School of Medical Sciences

Architect(s)

John Webster and E.J. Gilbert, Webster and Gilbert, Saskatoon

Builders

Smith Brothers and Wilson, General Contractors

Construction Dates

1945-1950

Recognition

University of Saskatchewan 'B' Listed

1. Statement of Significance

The Health Sciences Building, now known as 'Health Sciences A Wing', was the first medical building to be built at the University of Saskatchewan, completed in 1950. The Health Sciences A Wing has heritage value as the cornerstone of the medical precinct at the university. Designed by architects Webster and Gilbert, this 4-storey Collegiate Gothic structure maintains a high degree of commemorative integrity. Its front façade, in particular, remains essentially unchanged from the original design.

The School of Medical Sciences began as a two year pre-clinical program at the University of Saskatchewan where it was first located in the [Header Houses](#) near the [MacKinnon Building](#). In 1937 the school moved into the top two floors of the [Archaeology Building](#) before finding its home in the newly constructed School of Medical Sciences Building, starting in 1949. The school was connected to the University Hospital when that building opened in 1955 and a B Wing was added in 1969. Additions to the building continue to be made, most recently with the Academic Health Sciences D and E wings. The additions to the building are beyond the scope of this report.



Figure 1. Stone materials: greystone and Tyndall stone.



Figure 2. Granite steps and greystone wall.

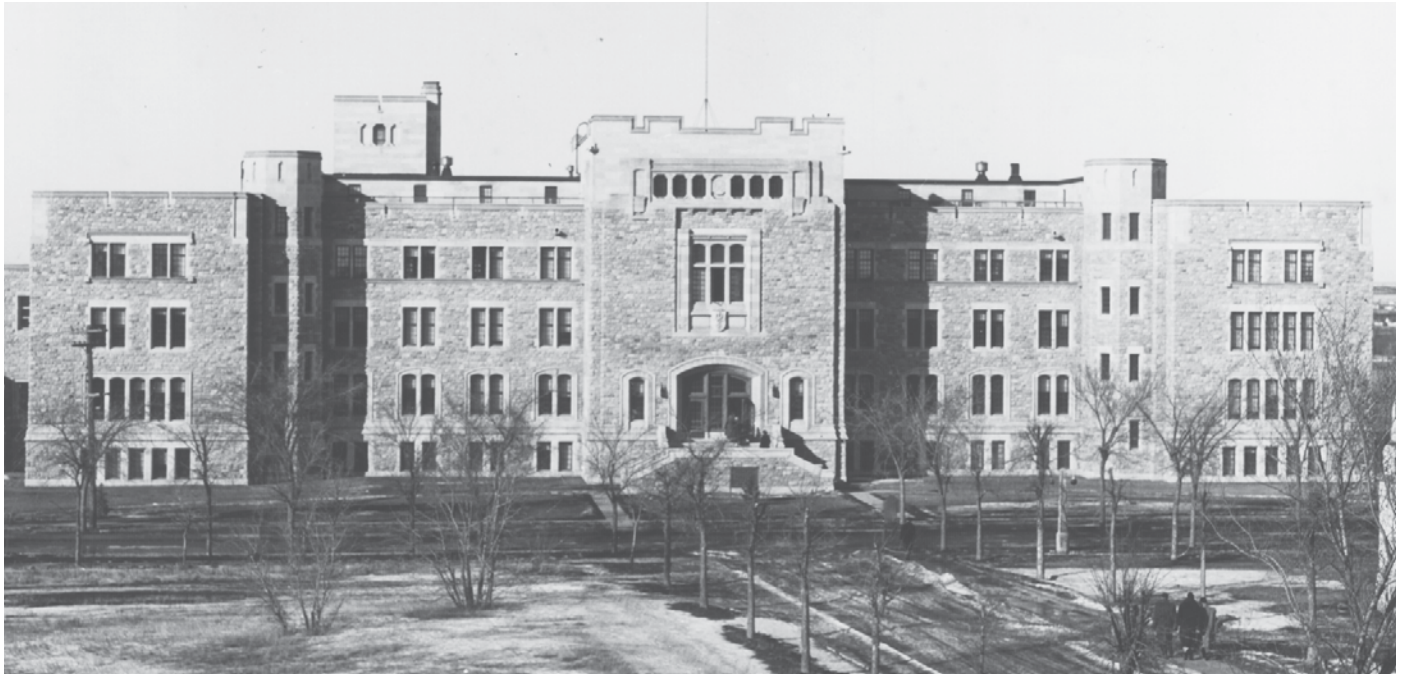

Figure 3. The front facade of the Health Sciences Building, February 1954. Photo A-519, retrieved from University of Saskatchewan Archives.

The School of Medical Sciences transitioned into a degree-granting College in the years 1952-1957. In 1957 the first class of M.D.'s at the University of Saskatchewan graduated from the program. The cornerstone of the Health Sciences Building was laid by the 'Father of Medicare,' Tommy Douglas.

Note: The Health Sciences Building is configured with floors numbered First Floor, Second Floor, etc... This report follows the same convention.

2. Character - Defining Elements

2.1 Materials

The exterior of the Health Sciences A Wing is faced in materials common to the University of Saskatchewan. The most prominent of these character-defining materials is 'greystone,' the local stone used on many earlier buildings. Greystone is complemented by cut Tyndall stone ornamentation (Figure 1). A granite base and steps (Figure 2) complete the stone materials of the exterior. The greystone, Tyndall stone and granite are all character-defining elements. The greystone that surrounds the entrance stairwell exists in a threatened state of commemorative integrity due to the poor condition of its mortar joints (Figure 2). All other stone is in good commemorative condition. (For further information on building stones used at the U of S, refer to ['Appendix: Stone.'](#)) Other materials visible on the exterior include oak doors and stained glass (Figures 4 & 5). The oak and stained

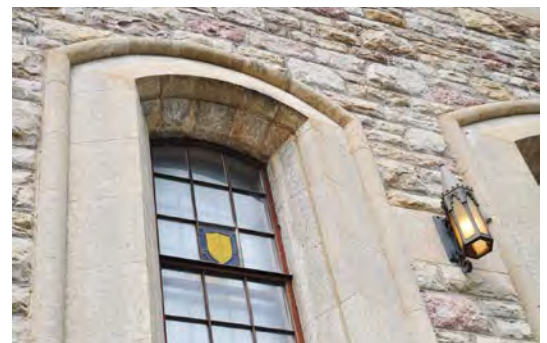

Figure 4. Arched windows with stained glass crest and steel light fixtures.

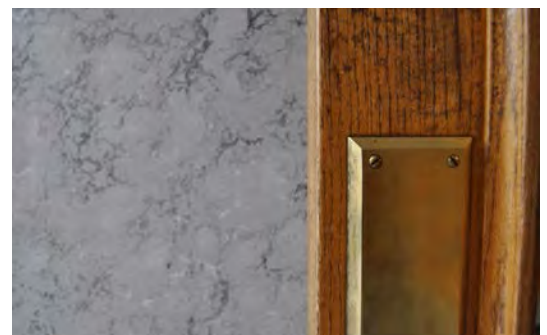

Figure 5. Oak, brass and marble.

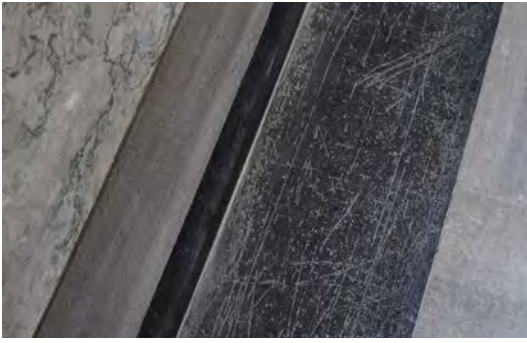

Figure 6. Marble, polished grey and black granite.



Figure 7. Steel sash window with brass fittings and oak trim.



Figure 8. Oak handrail and cast iron newel post with flower motif.



Figure 9. Yellow brick and terrazzo flooring with brass strips.

glass are also character-defining elements. On either side of the oak doors are steel light fixtures. Steel is also used for the window frames which are visible from the building's exterior. The stained glass and steel elements are shown in Figure 4. Copper flashing completes the character-defining materials of the building's exterior.

The vestibule inside the principal entrance has heritage value due to its granite and marble finishes. The vestibule has walls and flooring of grey marble paneling shown in Figure 5. The marble panels are complemented by polished black and grey granite surrounds shown in Figure 6. The granite and marble are character-defining elements of the building's interior. The wall mounted materials are in excellent commemorative condition, but the granite flooring shows wear.

The interior of the building is characterized by the use of oak, for doors, door frames, window frames and stair handrails. The doors in the building are in varying states of commemorative integrity. Many of the doors, including the exterior main entry door have been replaced in kind.

Window frames are of painted cold rolled steel. Most of the window frames appear to be original and many still have operable casements. Window hardware is generally original and of brass, as in many other buildings at the University (Figure 7). The original steel window frames and hardware are character-defining elements.

Staircases feature steel stringers, cast iron newel posts, steel balustrades and oak handrails (Figure 8). The corridors have painted plaster walls with brick wainscoting. The brick is in excellent commemorative condition. The plaster shows signs of deterioration in many places. The brick and plaster wall treatment is character-defining. The terrazzo flooring has brass strips, thresholds, drains and clean out covers. Terrazzo is used extensively in the building and also makes up wall bases, stair treads and window sills. The terrazzo and its brass components are character-defining materials that have retained their heritage value to a good degree of commemorative integrity (Figure 9). Original brass frames are also found on a few bulletin boards (Figure 10).



Figure 10. Brass-framed bulletin board.

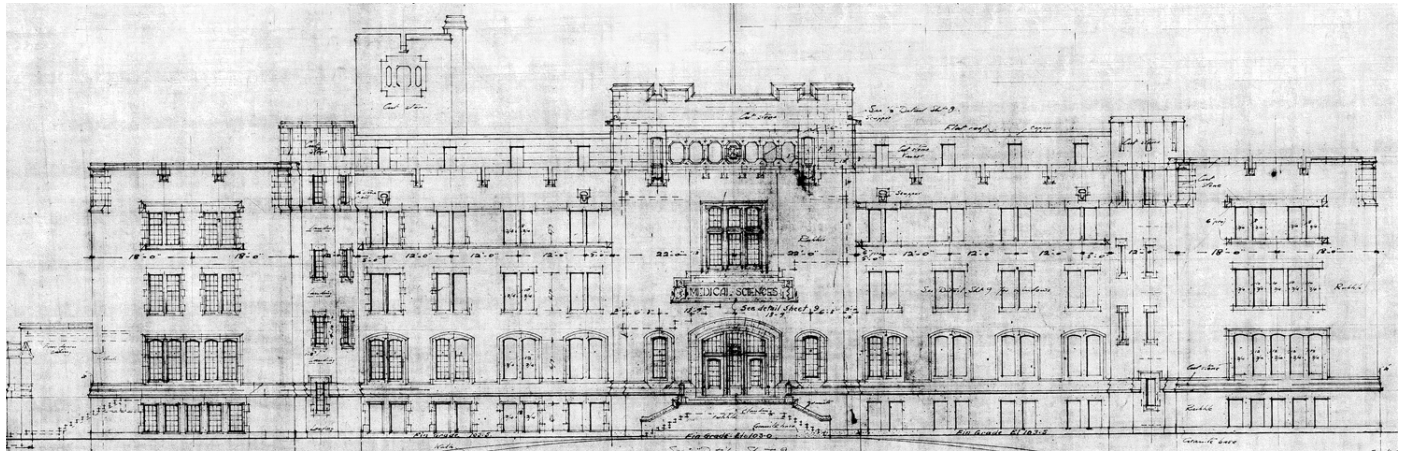

Figure 11. Front elevation. Retrieved from Facilities Management Division Asset Record System, File HS-44-T.

2.2 Form & Style

The Health Sciences Building was one of the later buildings to be constructed at the University of Saskatchewan in the Collegiate Gothic style. In plan, the building is arranged in the classic Elizabethan E-shape. Figure 11 illustrates the original front elevation of the building. Subsequent additions have obscured the E-shaped plan of the building from the rear, but the original front elevation has been well preserved.

The front elevation is symmetrical in composition, with the main entrance located centrally, and marked by a tower and a set of stone steps. Figure 12 shows the main entrance to the building, with its arched opening. Lanterns are hung on the walls on either side of the main entrance. The central tower is decorated with a crenellated parapet, statuary niches, scuppers and a row of octagonal windows (Figure 13). Stairwells are rendered on the front elevation as turrets (Figure 14). The stonework features decoration in the form of statuary niches, cut stone blanks and shields. A carved stone shield above the main entrance features the motif of the staff and snake, in reference to the medical professions (Figure 15). A prominent Tyndall stone stringcourse marks the base of the building (Figure 16). The parapet of the Health Sciences Building is constructed in cut Tyndall stone, and is one of the few modifications to the original front elevation, having been raised during the construction of the B-Wing, in 1968. It is decorated with crenellation in the form of archer style slots, and stone scuppers. Features of the Collegiate Gothic style such as arched openings, tower and turret forms, and carved stone decoration, are all character-defining elements.



Figure 12. Arched entrance and windows.

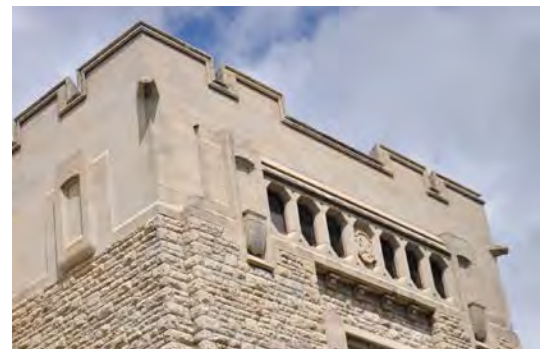

Figure 13. Crenellated parapet, statuary niches, octagonal windows, corbels and scuppers.



Figure 14. Octagonal stair tower.



Figure 15. Cut stone medical crest.



Figure 16. Stone string courses.

The interior of the building still holds some heritage value, although many original features have been lost to renovations. The brick wainscoting and original terrazzo floors in the corridors generally remain and are in good condition. Several arched openings remain (Figure 17). Most of the original features and finishes in the stairwells remain in place (Figure 8). Cast iron newel posts are decorated with a flower motif that is also found elsewhere on campus. Many of the stained glass windows visible from the exterior are also visible from the interior (Figure 18).

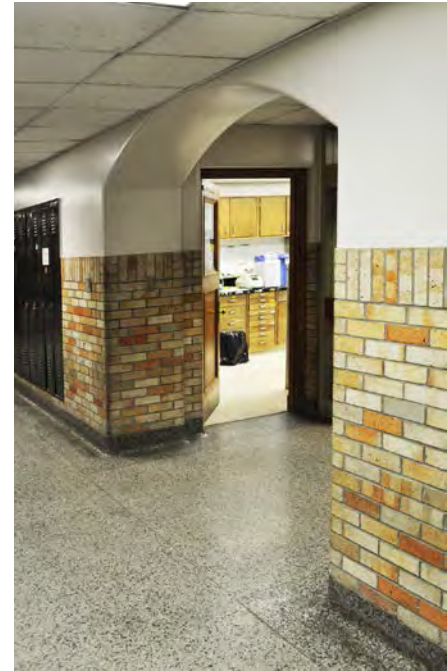

Figure 17. Arched entry, terrazzo floor and brick wainscoting.

Dropped ceilings have concealed a vaulted ceiling in the vestibule and arched ceilings in the first, second and third floor corridors.



Figure 18. Stained glass University of Saskatchewan crest.

2.3 Location

The Health Sciences Building is located off Wiggins court, near the Wiggins Avenue entrance to the University of Saskatchewan (Figure 19). From 1926 to 1937, the School of Medicine was housed in the [Horticulture Building](#) (Header Houses) (Figure 20), and later in the [Archaeology Building](#) (Figure 21). The Health Sciences Building was the first purpose-built medical building at the university. The subsequent construction of the Royal University Hospital and other medical buildings nearby has created a medical precinct. It was at this location that the School became the degree granting College of Medicine. The location of the building is of heritage value because it signaled the permanent establishment of the College of Medicine, and established a medical precinct.

2.4 Spatial Configuration

The original form of the Health Sciences Building is legible in plan, and the basic arrangement of its central wing, with rooms arrayed on either side of a double-loaded corridor, is intact. However, renovations, expansions and additions since its construction have transformed it from a discreet building into part of a complex of interconnected facilities. These changes have been invasive and in many cases have completely changed the spatial character of its spaces.

A comparison of Figures 22 and 23 shows the type of reconfiguration that generally took place on all floors. The addition of the B Wing to the west side of the building saw the deletion of all of the windows and doors on that façade. The staircase shown in the original plans on the west side of the building no longer exists. Rooms were removed from the west side of the building to make way for wider connective thoroughfares. On both the first and second floors, the large open plan rooms of the north wing have been extensively subdivided. The basement and the fourth floor (Figure 24) are the only levels which have escaped this reconfiguration.

A character-defining space was lost in the conversion of the double height lecture room of the second floor into a single height classroom. Figure 25 shows the original space in section. Figure 26 illustrates the original appearance of the space. A new floor was added to create a series of small rooms on the third floor where the upper portion of the lecture hall formerly existed. Figure 27 shows the current configuration of the space. The double height stained glass windows that originally allowed daylight into the space from the east have been concealed inside a small service stair. Figure 28 shows the rooms that were added on the third floor.



Figure 19. The location of the Health Sciences Building is indicated in green on this contemporary campus map.



Figure 20. 1931 Medicine class. Photo taken in front of the Header Houses where classes were held. Photo A-5742, retrieved from the University of Saskatchewan Archives.



Figure 21. Anatomy lab in the attic of the then Field Husbandry Building (now known as Archaeology). Retrieved from Buchan, D.J., *Greenhouse to Medical Centre Saskatchewan's Medical School 1926-78*.

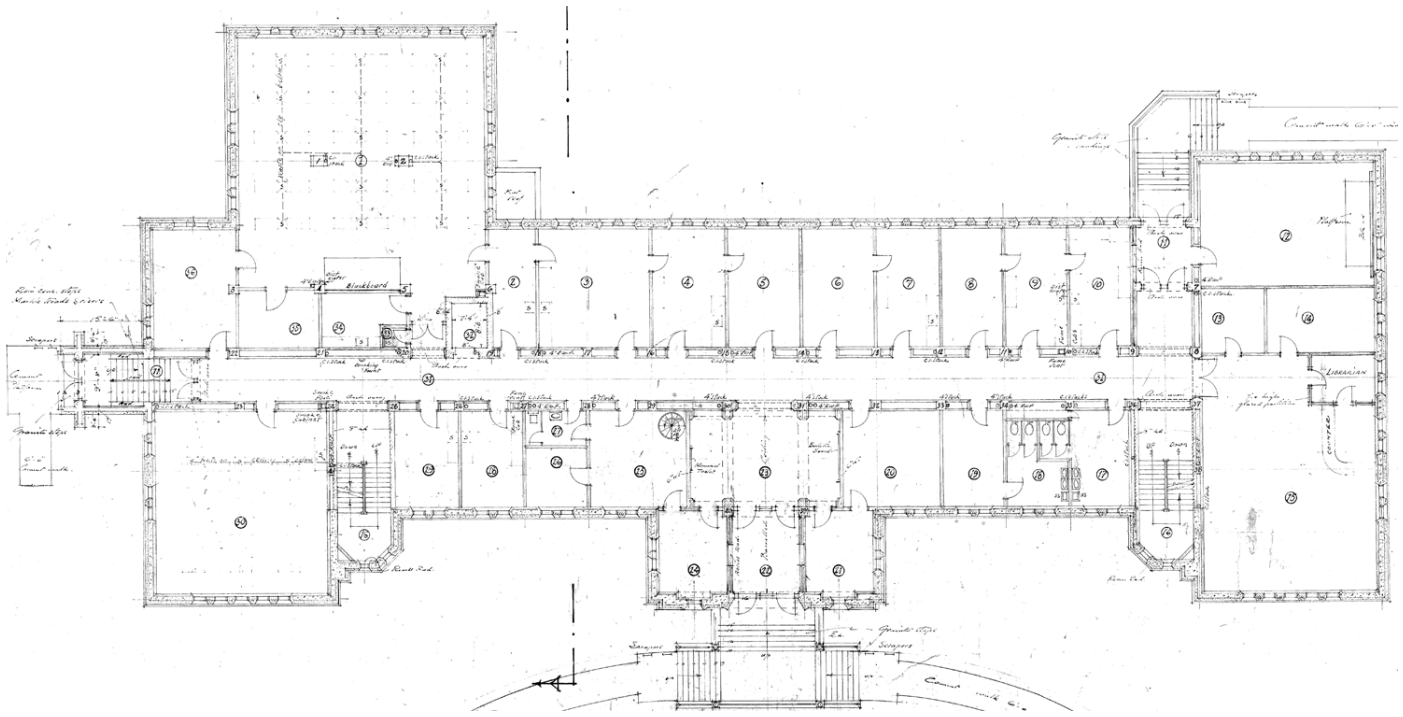

Figure 22. Original first floor plan. Retrieved from Facilities Management Division Asset Record System, File HS-49-T.

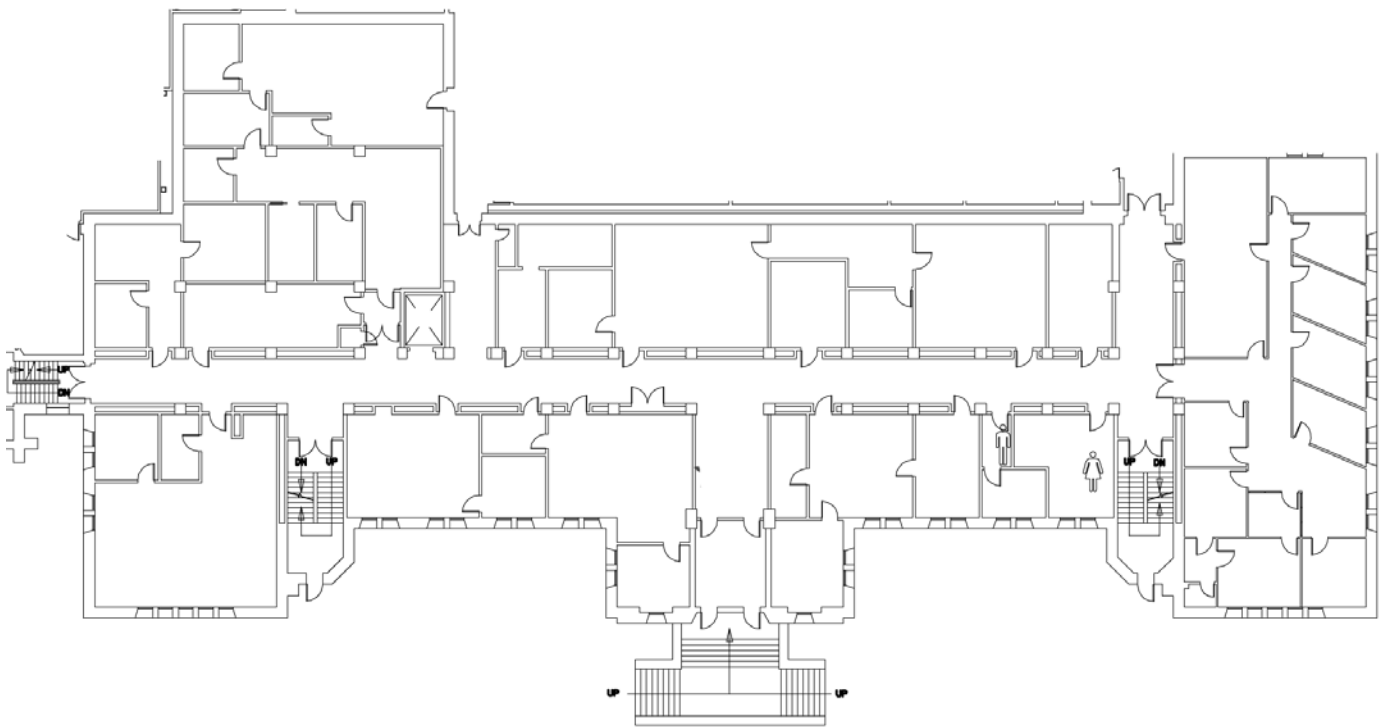

Figure 23. First floor plan after reconfiguration. Retrieved from Facilities Management Division Asset Record System, File 049-2139-T.

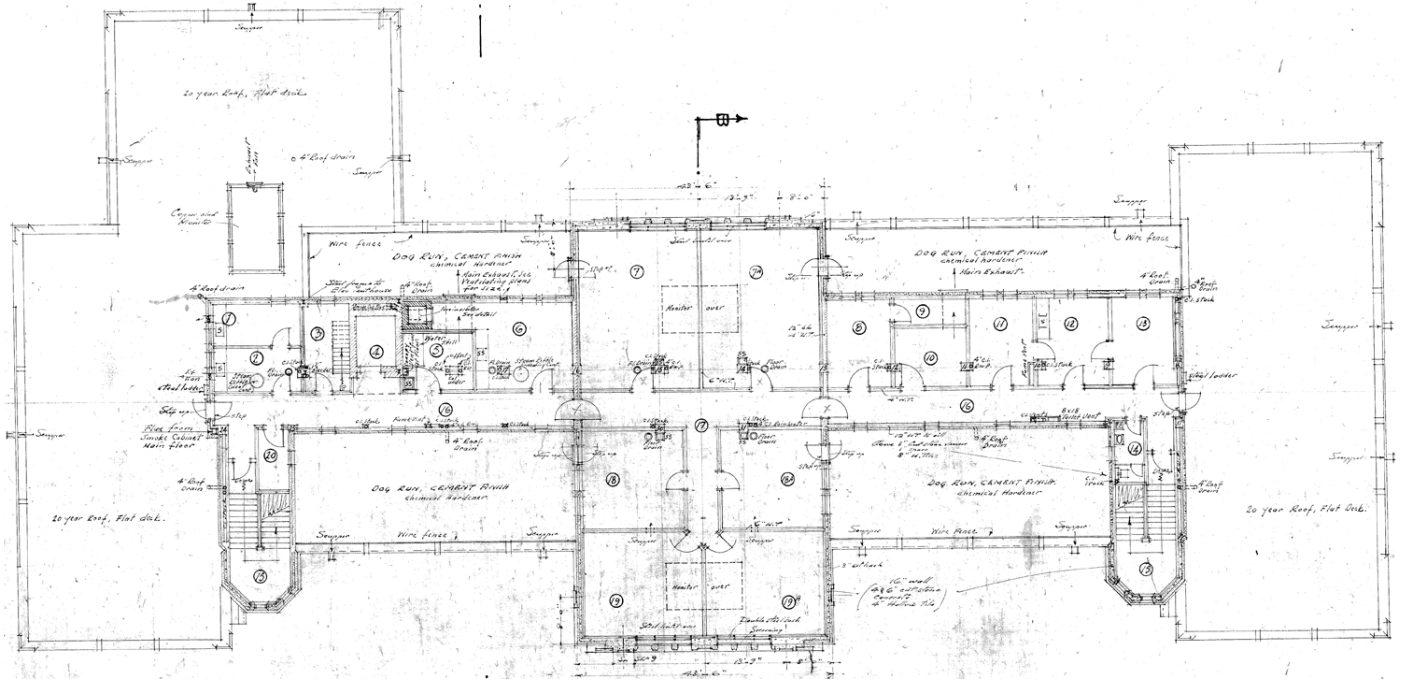

Figure 24. Original fourth floor plan. Retrieved from Facilities Management Division Asset Record System, File HS-46-T.

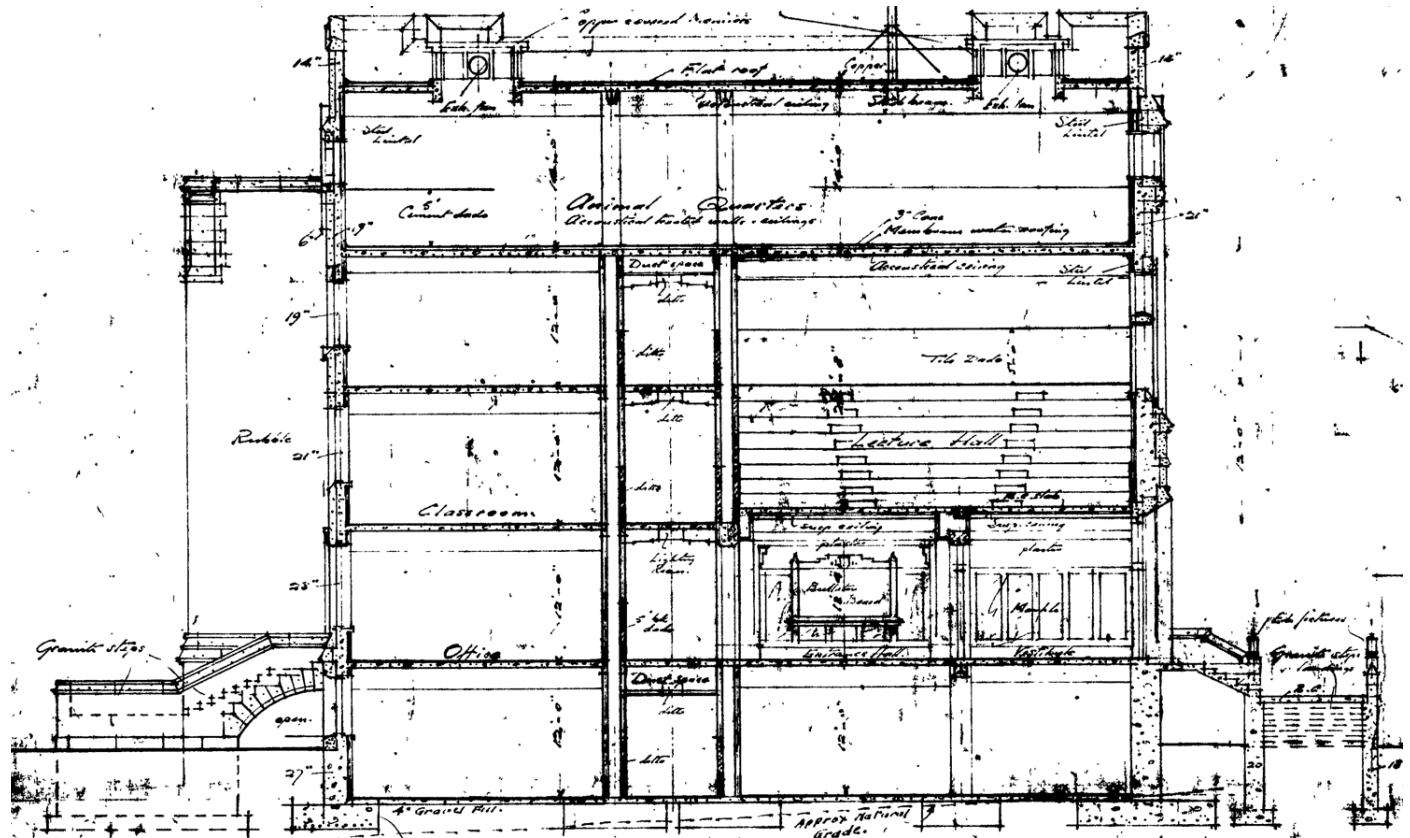

Figure 25. Section through the building showing double height lecture theatre. Retrieved from Facilities Management Division Asset Record System, File HS-45-T.



Figure 26. The lecture room as it was originally constructed. Retrieved from Buchan, D.J., *Greenhouse to Medical Centre Saskatchewan's Medical School 1926-78*.

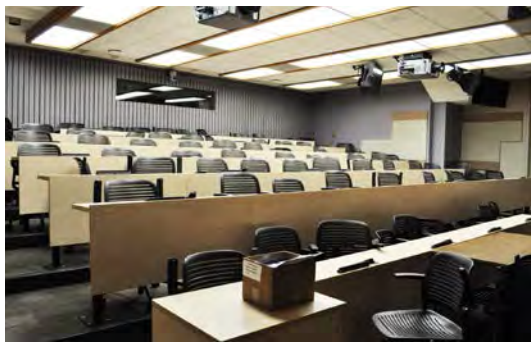

Figure 27. Current configuration of second storey lecture room.

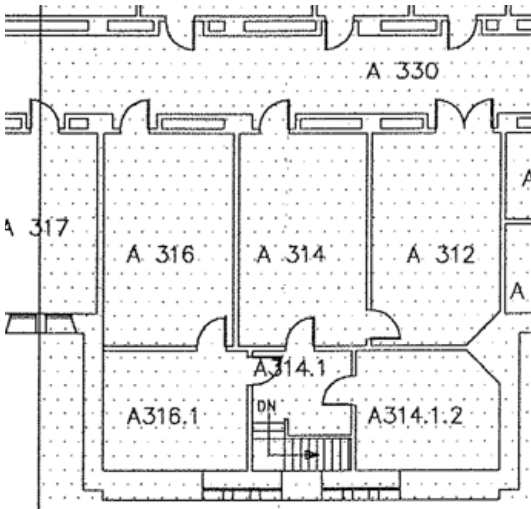

Figure 28. Current configuration of the former upper portion of the lecture theatre. Retrieved from Facilities Management Division Asset Record System, File 049-2149-T.

2.5 Systems

The Health Science Building was one of the first at the university to be constructed with an elevator. The original elevator is still intact and functioning in the building. It has steel doors with circular windows. Inside the steel doors are bronze scissor gates that are operated by the user (Figure 29). The style and materials of the elevator are character-defining elements.



Figure 29. Elevator gates.

The Health Sciences Building is one of the last buildings at the university constructed with load-bearing masonry walls rather than a structural steel or concrete frame. Floors are constructed of reinforced concrete slabs, supported by steel beams. The steel beams are supported on steel columns in the interior and by the exterior masonry walls.

2.6 Use(s)

The Health Sciences Building has heritage value in having been used continuously for medical education, and many of its spaces are still used for the activity for which they were originally intended. The use of the building for research, administration and education in health sciences is a character-defining element.

2.7 Cultural & Chronological Associations

The Health Sciences A Wing is associated with the College of Medicine and with the history of medical education and research at the University of Saskatchewan. It can also be associated with Tommy Douglas, Premier of Saskatchewan from 1944 to 1961. Douglas led the Co-operative Commonwealth Federation (CCF), the first democratic socialist party to form government in North America. Douglas is best known for his contributions in healthcare including a government provided province wide hospitalization program, establishing the College of Medicine at the University of Saskatchewan and establishing the first publicly funded health care system in North America. Douglas laid the cornerstone for the building on August 26, 1946 (Figures 30 & 31). The cornerstone is a character-defining element.



Figure 30. The laying of the cornerstone by Premier Tommy Douglas, August 26, 1946. Photo A-3691, retrieved from University of Saskatchewan Archives.

3. Associated Objects

The third floor of the Health Sciences Building's A Wing holds the Geoffrey Jamieson painting collection. The collection consists of five separate panels painted on the walls of the south end of the corridor. The murals, painted in 1962, are reproductions of historic anatomy images. Jamieson, a former student of the College of Medicine, returned in the 1990's to touch up his art work. Figure 32 shows one of the paintings.

Further down the same corridor, display cases hold a collection of microscopes and microscope accessories (Figure 33). Also on the third floor in room A302 is the Van Leeuwenhook photo and microscope display.

On the first floor, the College of Medicine Medical Undergraduate Student Photograph Collection is displayed on the walls. The collection dates back to 1926 when the school first opened as a two year clinical program known as the School of Medical Sciences. The photos were examined by a restoration expert in 2004 who reported that the condition of some of the photos was very fragile. The most damaged of the photos have undergone restoration as a result.

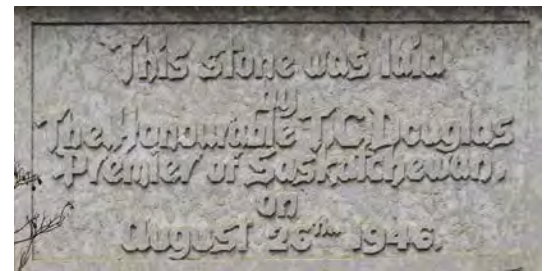

Figure 31. Cornerstone laid by Tommy Douglas.



Figure 32. Painting by Geoffrey Jamieson.



Figure 33. Microscope collection.

4. Supporting Documents

Buchan, D.J. (1983). *Greenhouse to Medical Centre Saskatchewan's Medical School 1926-78*. College of Medicine: University of Saskatchewan.

Facilities Management Division (2011). Asset Resource Database [Data File]. Retrieved from [\\usask\fmddfs\files\iis\IIS_Public\ARS](http://usask.fmddfs/files/iis/IIS_Public/ARS)

Rosser, B., personal communication. June, 2012.

Silversides, B. (1985). Saskatoon Architects 1905-1920. *Saskatoon History*, 3, 20-37.

University of Saskatchewan Archives. (Retrieved 2012). *Building Chronology*. Retrieved from http://scaa.sk.ca/gallery/uofs_buildings/

Quiring, B. (Retrieved 2012). *The encyclopedia of Saskatchewan, Douglas, Thomas Clement*. Retrieved from http://esask.uregina.ca/entry/douglas_thomasclement_1904-86.html

5. Summary of Character - Defining Elements

Materials

- rough-faced greystone walls
- cut Tyndall stone trim & decoration
- grey marble floors
- oak doors & millwork
- copper flashing
- slate chalkboards
- steel-framed windows
- painted steel & cast iron balustrades & stairs
- terrazzo flooring, wall bases, window sills and stair treads
- grey granite base and steps
- black granite
- yellow brick wainscoting

Form & Style

- symmetrical form and elevations
- classic Elizabethan E-shape
- rectangular massing
- central tower element
- front steps
- arched windows and entrance
- octagonal windows
- corbels
- stone scuffers
- barrel vault and stepped ceilings
- crenellation
- parapet (battlement)
- quoins
- statuary niches
- stone and stained glass crests

Location

- University of Saskatchewan
- medical precinct

Spatial Configuration

- double loaded corridors
- stair towers

Systems

- composite structure of load-bearing masonry walls and steel structural frame, concrete slabs.

Uses

- medical education and research

Cultural & Chronological Associations

- cornerstone laid by T.C. Douglas



051

Memorial Union Building

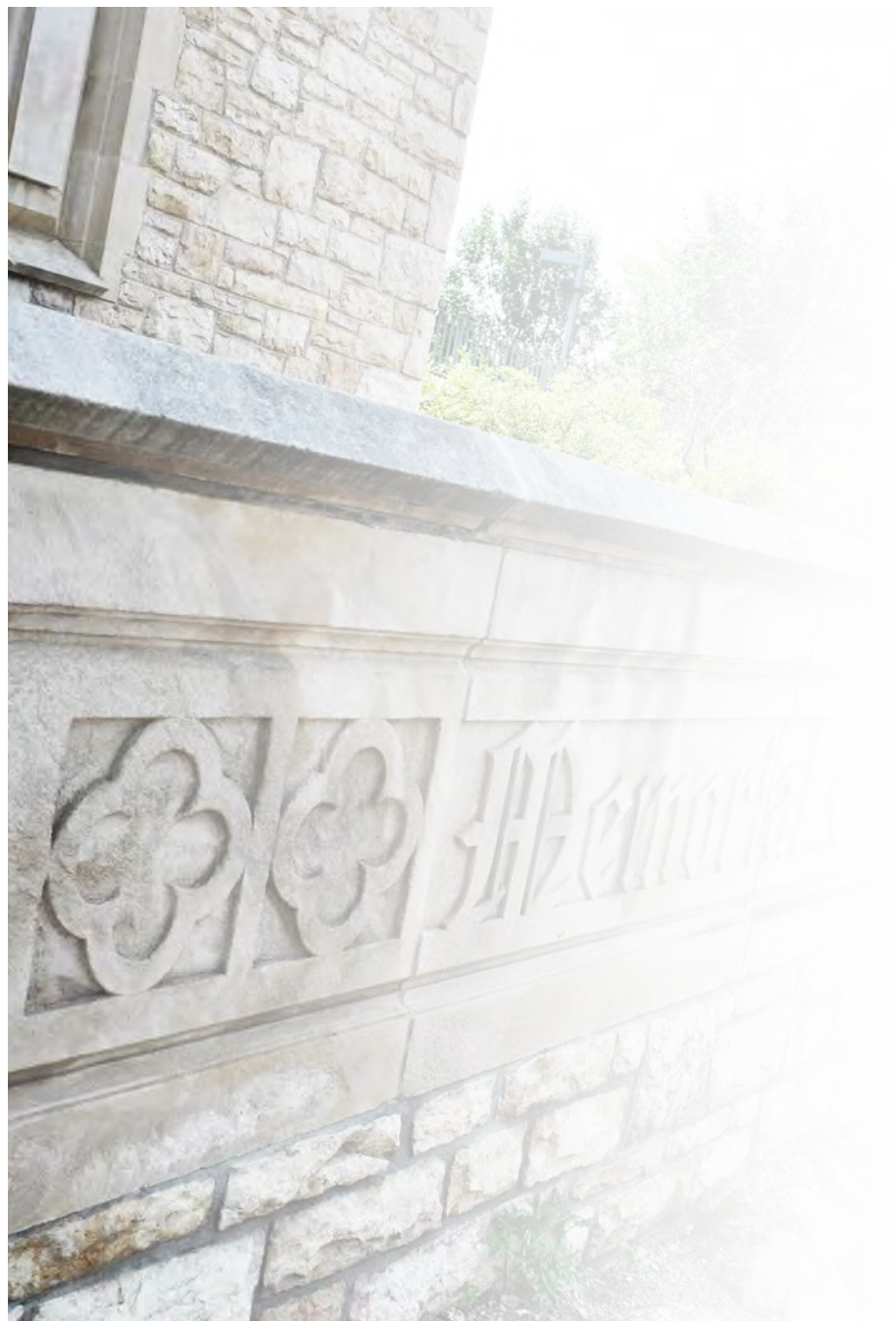

051

Memorial Union Building

Alternate Names

MUB

Architect(s)

Shore and Moffat, Toronto

Builders

Smith Brothers and Wilson, General Contractors

Construction Dates

1953-1955

Recognition

University of Saskatchewan 'B' Listed



Figure 1. Greystone and Indiana limestone.



Figure 2. Tyndall stone steps.

1. Statement of Significance

The Memorial Union Building (MUB), designed by Shore and Moffat Architects of Toronto, opened on Remembrance Day in 1955. The building was intended both as a centre for student activities and as a tribute to the members of the university community who had given their lives in the Second World War. The centerpiece of the building is a large stone fireplace with a marble memorial tablet engraved with the names of the fallen soldiers. The student body raised \$200,000 towards the \$570,000 construction cost of the building. The Memorial Union Building is notable as one of the last Collegiate Gothic buildings erected at the university. [St. Thomas More College](#) (1954-1956) and the [St. Andrew's College](#) addition (1959-1961) are the other buildings roughly contemporary with the Memorial Union Building and designed in the Collegiate Gothic style. These buildings are somewhat anachronistic in that by the 1950's,



Figure 3. The Memorial Union Building, 1958. Photo A-563, retrieved from <http://sain.scaa.sk.ca/items/index.php/memorial-union-building-exterior-13;rad>.

historicist architectural styles had generally fallen out of favour in Canada, and Modernism had become the prevailing architectural idiom.

The Memorial Union Building was designed to accommodate expansion to the south and saw renovation throughout the 1980's and again in recent years. However, expansion could not accommodate the rapid expansion of student numbers during the 1960's, and plans for the Place Riel Student Centre were drawn up after it became apparent that the MUB did not have the capacity required.

Note: The Memorial Union Building is configured with floors numbered Basement, First Floor, Second Floor. This report follows the same convention.

2. Character - Defining Elements

2.1 Materials

The stone facade of the Memorial Union Building (MUB) is an important character-defining element. The exterior of the building is composed of 'greystone' walls, cut Indiana limestone trim and Tyndall stone steps and thresholds (Figures 1 & 2). Tyndall stone and greystone are both found on the interior surrounding the commemorative fireplace on the second floor. The roof is clad in slate, and flashing, downspouts and gutters are in copper (Figure 4). The original exterior materials of the



Figure 4. Slate tile roof and copper downspout.



Figure 5. Oak door with glazed panels, brass door pulls, hinges and lock.



Figure 6. Brass door pushes.

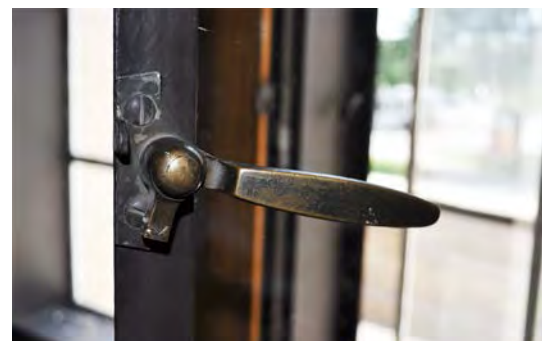

Figure 7. Steel sash, brass window handle.



Figure 8. Marble window sill, painted oak window frame and steel sash.



Figure 9. Terrazzo with brass strips.



Figure 10. Oak paneling, unpainted at top and painted at bottom. Terrazzo stairs with steel balustrade and oak banister.

Memorial Union Building – greystone, Indiana Limestone, Tyndall stone, slate and copper – are character-defining elements. (For further information on building stones used at the U of S, refer to [‘Appendix: Stone.’](#))

The windows and doors of the building contribute to the character of both the interior and the exterior of the building. The building has two sets of large oak doors with brass kick plates and hardware (Figures 5 & 6). The main entrance doors see the most use and show signs of wear. The interior vestibule doors are also in poor condition. The northern door and its brass fixtures are in good commemorative condition. The oak doors and brass fittings are character-defining elements.

Painted steel-framed sash windows are used throughout the building, with limestone trim on the exterior and oak trim on the interior. The windows are single-paned, but are arranged in two layers, with an interior and exterior set for each opening. The window hardware is in brass (Figure 7). The second storey windows have window sills made of a buff coloured marble (Figure 8). The same marble makes up the cenotaph commemorating the war dead and it exists in a state of excellent commemorative integrity. On other floors, the window sills are made of terrazzo. The windows and their materials are in excellent commemorative condition with few exceptions and are character-defining elements. The marble of the cenotaph is also a character-defining material element.

Much of the original flooring materials have been replaced. The ground floor and main staircase have retained their terrazzo finish (Figure 9). The staircase (Figure 10) is formed of cast-



Figure 11. Voyager Place as seen with the Memorial Union Building. Photo A-564, retrieved from University of Saskatchewan Archives.

in-place concrete with terrazzo treads and risers, painted steel balusters and an oak handrail. The stairwell features oak wall paneling. The original materials of the staircase and stairwell are character-defining elements.

Most of the original interior layout has been altered over time.

2.2 Form & Style

The Memorial Union Building is a modestly-scaled building in the Collegiate Gothic style. It sits three storeys above grade, including its attic level, and features pitched gabled roofs. The landscaping surrounding the building serves to enhance its scale, as it was built with raised terraces on the north and west sides. Since its original construction, a raised patio has been added to the south. (See Section 2.4 Spatial Configuration).



Figure 15. Bay window.

The Memorial Union Building is essentially rectangular in plan, with its stairs contained in protruding volumes on the north and south sides, making the overall form irregular. In elevation, it is asymmetrical, with the principal entries being located off centre on the north and west facades. As shown in Figure 11, the north face of the Memorial Union Building terminates the outdoor area between [Saskatchewan Hall](#) and [Qu'Appelle Hall](#) known as [Voyageur Place](#).

The exterior detailing is somewhat simplified compared to earlier examples of Collegiate Gothic architecture at the university. The Memorial Union Building has greystone quoins on its corners and limestone string courses (Figure 12). Cut and carved stone features include false slot windows (Figure 13) in the gable ends and a sign carved in relief on a low wall of Indiana limestone (Figure 14). A bay window (Figure 15) balances the north elevation (Figure 16). Stone spandrels, also visible in Figure 15, accompany many of the windows. Cut stone arches surround arched doorways on both the north (Figure 17) and west facades. The west entrance is enclosed in a shallow architrave. All of these are character-defining elements of the Collegiate Gothic style. The arch of the west facing entrance is currently obscured by a canopy. Historic pictures show that a stone blank is hidden



Figure 12. Indiana limestone string course in a greystone wall.



Figure 13. Archer style slot under peaked parapet roof form.



Figure 14. 'Memorial Union Building' in cut stone.



Figure 16. North elevation. Retrieved from Facilities Management Division Asset Record System, File MU-44-T.



Figure 17. Cut stone arched entrance and doors.

by the canopy as well. The canopy reduces the commemorative integrity of the façade as it obscures the character-defining elements of the arch and the stone blank.

The Memorial Union Building is anachronistic in its architectural style. By 1955, historicist architectural styles had generally fallen out of favour, and Modernism had become the prevailing architectural idiom in Saskatchewan and across Canada. Compare, for example, the simplified form, massing and detailing of the [Murray Library](#), which opened the same year, to the Collegiate Gothic Memorial Union Building.

The scale, form and style of the original building are all intact, despite several additions and renovations, and are character-defining. The aspects of form and detailing that identify this building as Collegiate Gothic in style are character-defining.

2.3 Location

The idea for a memorial emerged shortly after the end of the Second World War. On November 21, 1947, 186 students, each with a torch, gathered in the courtyard between Saskatchewan Hall and Qu'Appelle Hall to honor all of the students and alumni who gave their lives in the Second World War. Lieutenant Governor R.J.M. Parker unveiled a marker, and the future site of the Memorial Union Building was announced. Figure 18 captures the scene. The Memorial Union Building was erected at the south end of [Voyageur Place](#). The Memorial Union Building was intended to be the centre of student life, featuring an auditorium, a ballroom, lounge rooms, a tuck shop and a student office. Its location near the residences, [Qu'Appelle Hall](#) and [Saskatchewan Hall](#), was integral to these intended uses.

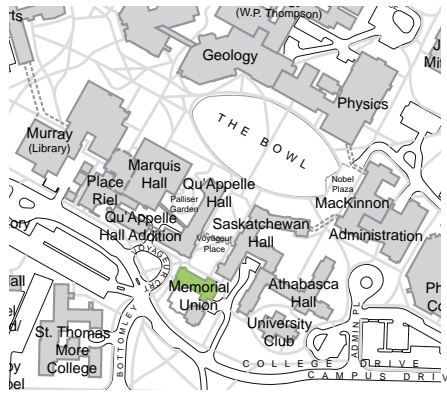

Figure 19. The MUB is indicated in green on this contemporary campus plan.

With the completion of the building, Voyageur Place (as it was later known) became enclosed on three sides, open only to ‘[The Bowl](#)’ (Figure 19). The 1909 Campus Plan by architects Brown and Vallance shows a building in this location (Figure 20). Although not realised exactly as planned, the Memorial Union Building is in keeping with the original intent.

2.4 Spatial Configuration

The spatial configuration of the Memorial Union Building has undergone many changes. Each of the floors of the building was originally laid out with a large central open space, and smaller enclosed rooms at either end. Only the second floor now retains this general configuration.

The first floor originally contained a large cafeteria space, supported by a kitchen, a dining room, a lounge and some offices (Figure 21). This floor is now divided up into smaller meeting rooms and offices for various student clubs (Figure 22).

The second floor originally contained a large lounge space, with smaller conference rooms at the east end (Figure 23). The large greystone fireplace and marble memorial tablet formed the central feature of this space (Figure 24). The configuration of the second storey has been essentially maintained. The conference rooms have been replaced by washrooms, but the lounge has been maintained in the form of a café, and the memorial fireplace remains intact.



Figure 18. November 21, 1947. Students gather to honor colleagues who fell in the Second World War with a torchlight parade and the unveiling of a marker. The siting of the Memorial Union Building was also announced. The future location of the MUB is in the foreground. Photo A-8665, retrieved from <http://sain.scaa.sk.ca/items/index.php/university-of-saskatchewan-archives;jsdiah>



Figure 20. The building indicated in green on the 1909 Campus Plan is in the approximate location of the Memorial Union Building.

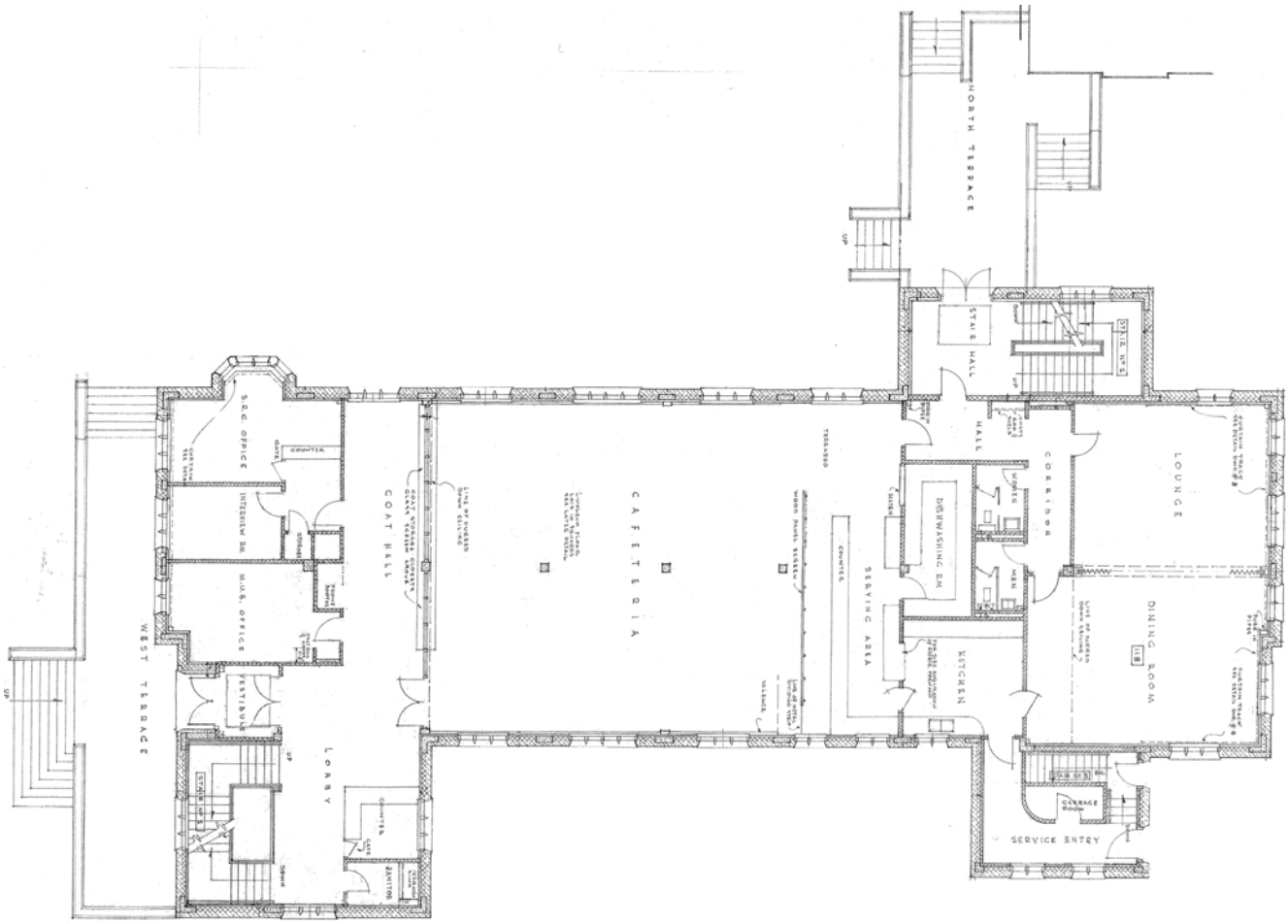

Figure 21. Original first floor plan. Retrieved from Facilities Management Division Asset Record System, File MU-46-T.

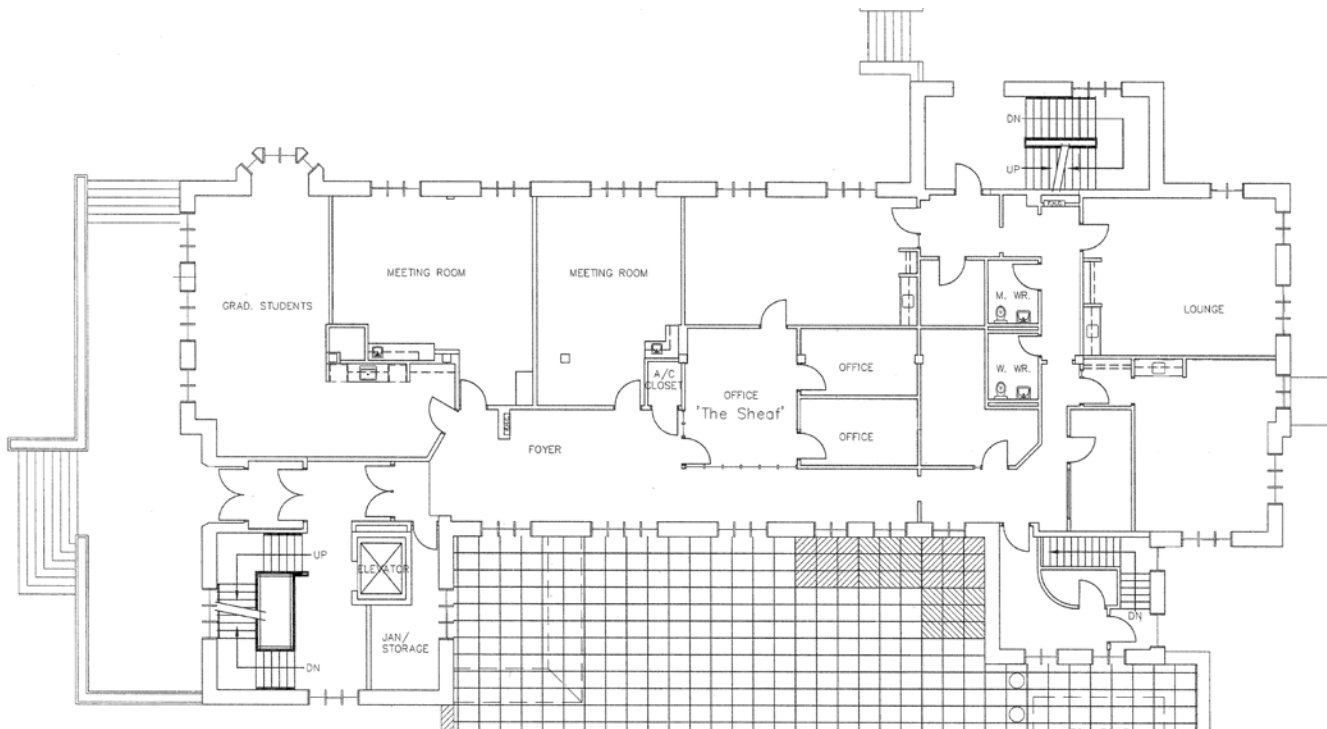

Figure 22. First floor plan as it currently exists. Retrieved from Facilities Management Division Asset Record System, File 051-405-T.

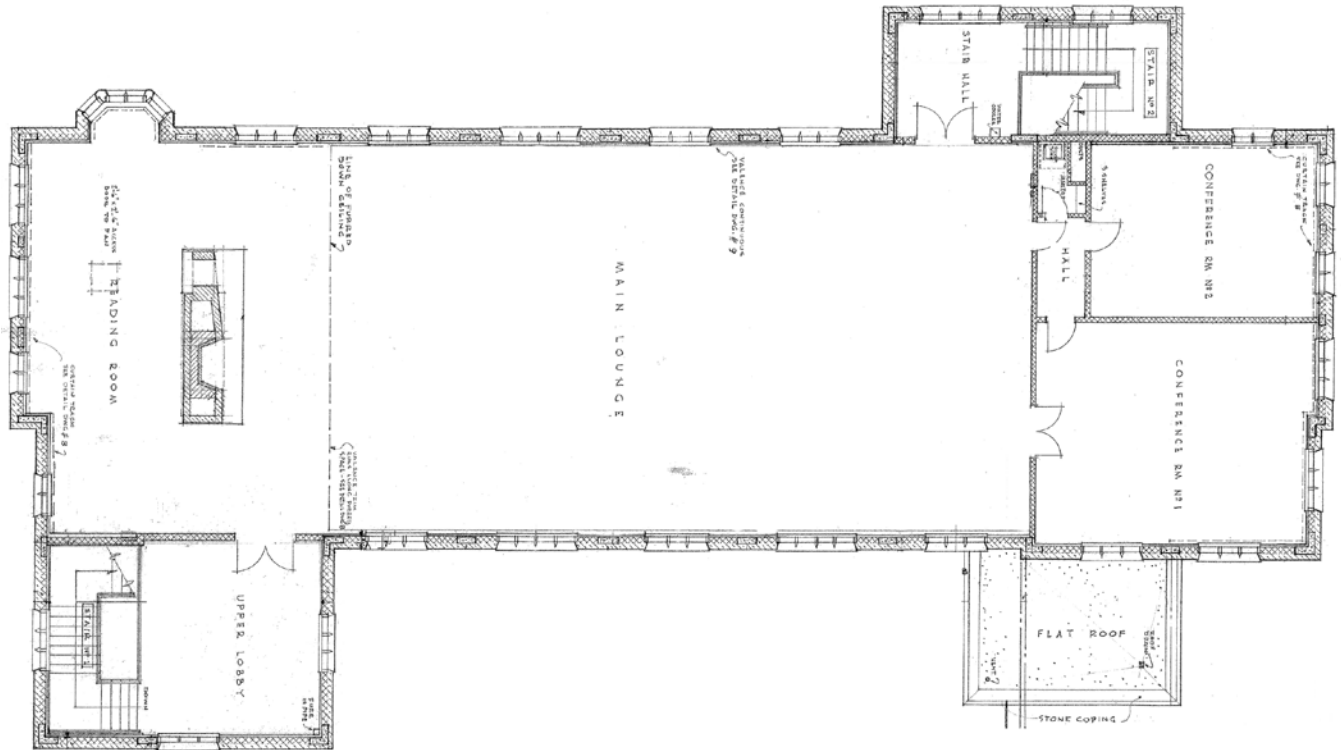

Figure 23. Original second floor plan. Retrieved from Facilities Management Division Asset Record System, File MU-45-T.

The basement originally contained a large games room. The west end of the floor was divided into washrooms and mechanical rooms and the east end held offices and a studio (Figure 25). A row of windows allowed day light into the space from the south side. This basement now contains the student bar, Louis'. Although open in plan, the floor has been segmented into different levels accessed by ramps. A stage was added to the south side of the space and the windows there have been removed. The MUB was built with a basement tunnel connecting it to [Saskatchewan Hall](#). The tunnel is intact.

2.5 Systems

The Memorial union building has a cast-in-place concrete structural frame, consisting of a concrete slab and joist system on concrete beams and columns. Pitched roofs have wood decking on wood purlins, supported by steel trusses. Flat roofs have concrete slabs. The foundation walls and footings are cast-in-place concrete. The walls appear to be non-structural, and consist of stone and clay tile, with cork insulation and a plaster finish. Interior partitions that are original to the building are built with 4" - 8" hollow clay tile.



Figure 24. The second floor lounge as it was originally configured, 1956. Photo A-592, retrieved from University of Saskatchewan Archives.

2.7 Cultural & Chronological Associations

The Memorial Union Building can be chronologically and culturally associated with the Second World War, as a memorial to the members of the university community who perished in that conflict. Figure 29 shows the unveiling of the memorial plaque in 1955.

3. Associated Objects

The fireplace and the marble memorial plaques on the second floor are objects significant to the Memorial Union Building (Figure 29 & 30).

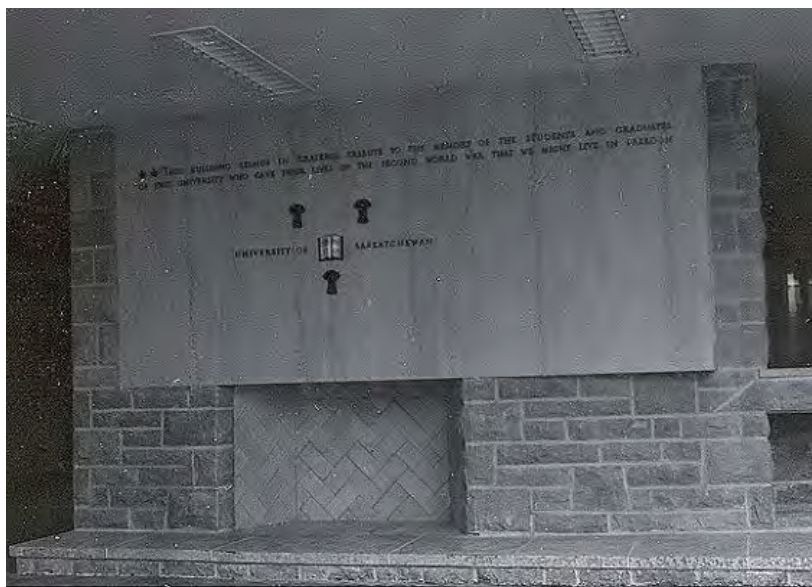

Figure 30. The memorial hearth. Photo A-588, retrieved from http://scaa.sk.ca/gallery/uofs_buildings/



Figure 27. Students in the lounge, 1956. Photo A-572, retrieved from University of Saskatchewan Archives.



Figure 28. The ground floor cafeteria, 1956. Photo A-577, retrieved from <http://sain.scaa.sk.ca/items/index.php/university-of-saskatchewan-archives;jsdiah>



Figure 29. The unveiling of the memorial, November 11, 1955. Photo A-588, retrieved from University of Saskatchewan Archives.

4. Supporting Documents

Facilities Management Division (2011). Asset Resource Database [Data File]. Retrieved from \\usask\fmddfs\files\iis\IIS_Public\ARS

University of Saskatchewan Archives. (Retrieved 2012). *Events in the History of the University of Saskatchewan 1965: CJUS-FM launched*. Retrieved from http://scaa.usask.ca/gallery/uofs_eventsarticles/1965.php

University of Saskatchewan Archives. (Retrieved 2012). University of Saskatchewan Archives, RGM 300.32, Misc. 1959 Appraisal of the University.



5. Summary of Character - Defining Elements

Materials	<ul style="list-style-type: none">▪ greystone walls▪ limestone ornamentation▪ slate roof▪ Tyndall stone steps and plaza▪ oak banister, doors and surrounds▪ brass door & window hardware▪ steel balustrade▪ steel window frames▪ terrazzo flooring▪ marble window sills
Form	<ul style="list-style-type: none">▪ pitched gabled roofs▪ raised terraces▪ facades and entrances<ul style="list-style-type: none">▪ scale
Style	<ul style="list-style-type: none">▪ quoins▪ arched entries▪ spandrels▪ string courses▪ archer slots▪ carved stone relief reading 'Memorial Union Building'<ul style="list-style-type: none">▪ bay window
Location	<ul style="list-style-type: none">▪ Voyageur Place▪ between student residences
Spatial Configuration	<ul style="list-style-type: none">▪ open layout of second storey▪ offices on first floor▪ staircase▪ tall windows
Systems	<ul style="list-style-type: none">▪ hollow tile partitions▪ steel trusses
Uses	<ul style="list-style-type: none">▪ offices of The Sheaf▪ USSU offices▪ lounge▪ dining
Cultural & Chronological Associations	<ul style="list-style-type: none">▪ Second World War



053

Murray Building

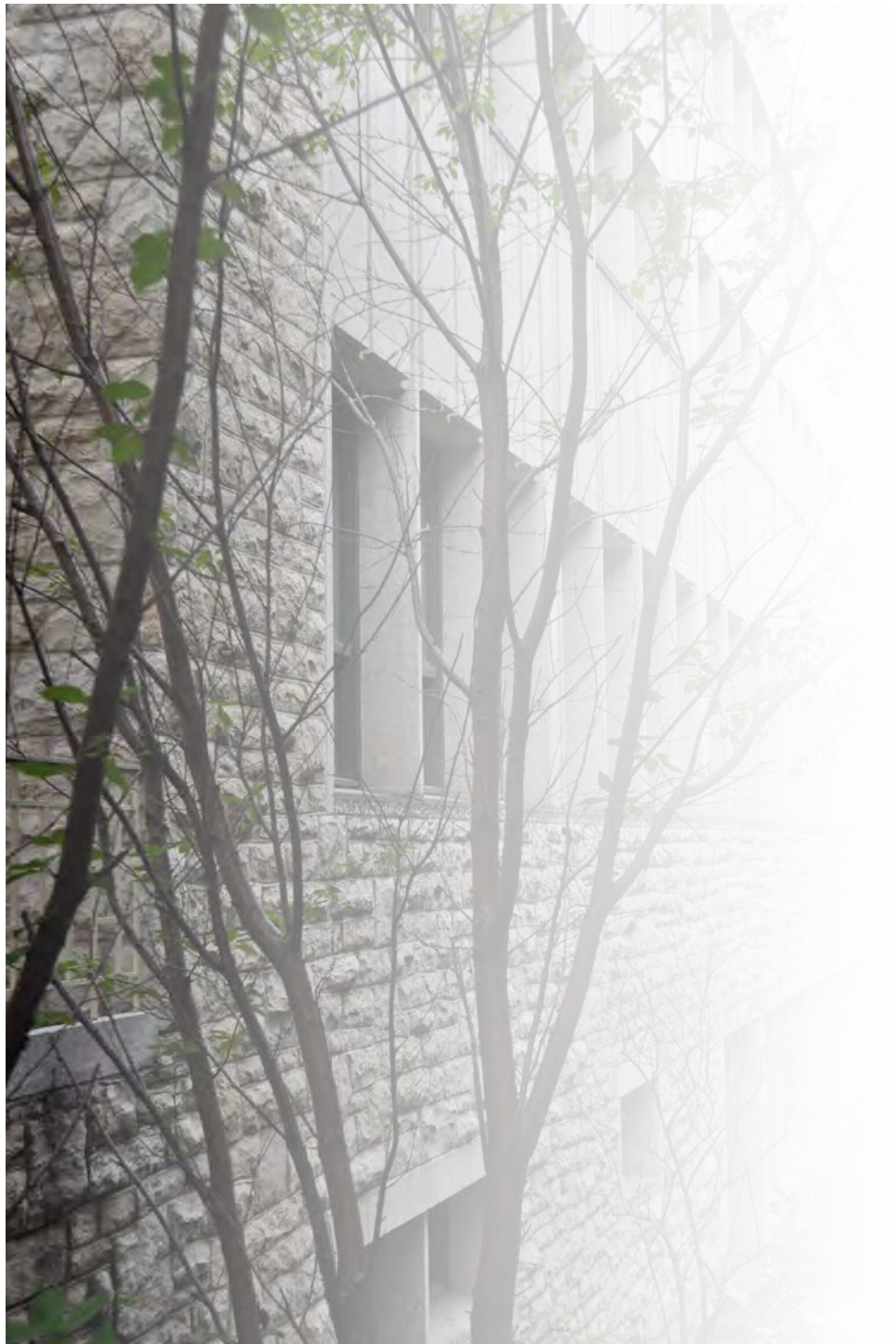

053

Murray Building

Alternate Names

Murray Memorial Library

Architect(s)

K. Izumi, project architect for H.K. Black Architect, Regina

Builders

W.C. Wells Construction

Construction Dates

1954-1956

Recognition

University of Saskatchewan 'B' Listed



Figure 1. Tyndall stone and greystone.



Figure 2. Granite steps and Tyndall stone pavers.

1. Statement of Significance

The Murray Building, designed by noted Regina architect Kioshi Izumi working under H.K. Black Architect, was built between 1954-56. It is architecturally significant as one of the first Modernist buildings constructed at the University of Saskatchewan, and the first to use a full structural steel frame. (The Heating Plant, constructed at the same time, is also in the Modern style). Architecturally, it is also notable that at the moment of transition between the historicist impulse of the Collegiate Gothic and the modernist idiom of the Murray Building, a decision was made to continue the use of 'greystone' and Tyndall stone as the principal exterior materials. The Murray Building is also significant as the university's first formal library building. Prior to its construction, the library collection was located in the [MacKinnon Building](#) or scattered in smaller

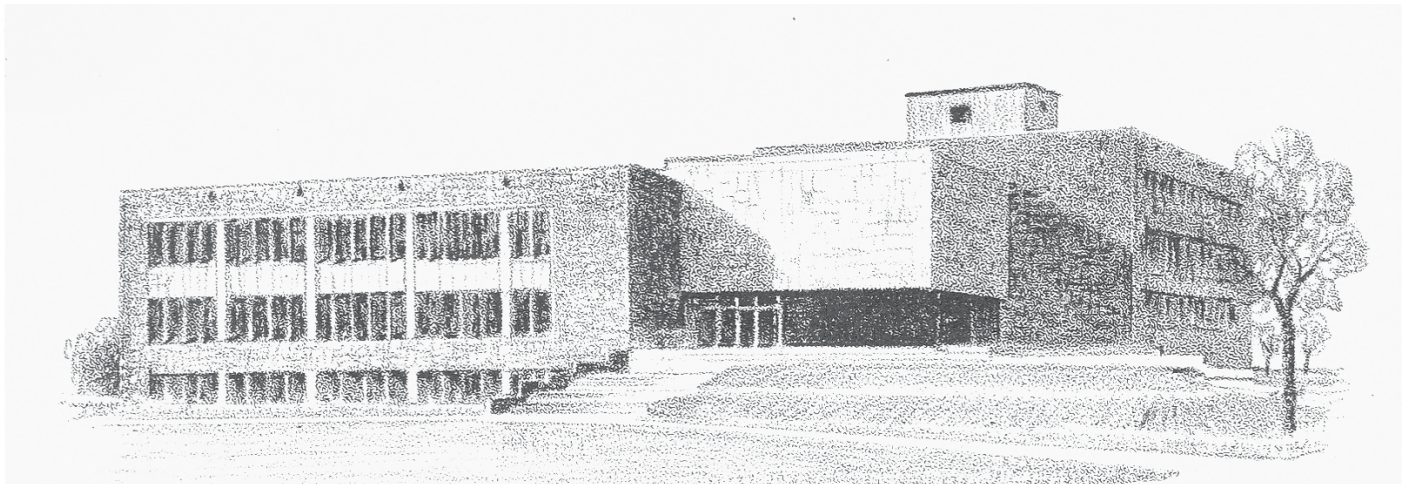

libraries throughout the campus.

The Murray Memorial Library, as it was originally named, was built in honor of the university's first president, Walter C. Murray. Murray died in 1945 never having seen his university build a library. After his death, a memorial fund was started in his honor with the purpose of constructing a library. The Murray Building represents the fruits of the memorial fund and a tribute to Walter Murray.

A large addition to the Murray Building was constructed to the south of the original building between 1972-74. The 'South Wing' addition is beyond the scope of this report. The Murray Building is configured with its floors numbered ground floor, first floor, second floor etc...

Figure 3. A 1955 sketch by Professor Les Saunders depicts the Murray Building shortly after completion. Photo 2069-29-4, retrieved from <http://scaa.sk.ca/gallery/postcards/permalink/34240>

2. Character - Defining Elements

2.1 Materials

Although the Murray Building is designed in the Modern style, a conscious decision was made not to discard historic campus materials and scale. The exterior materials of the building include greystone, Tyndall stone and granite (Figures 1 & 2). Greystone and Tyndall stone, by this time, were firmly established as a unifying feature of the University of Saskatchewan campus. The Murray Building honoured this tradition, but re-imagined the meanings of these materials in the way they are expressed. Whereas earlier, greystone was used in a structural capacity, to support the weight of the building, here it is used as a non-structural cladding. Because the stone wall is no longer structural, the architect is free to arrange the elements of the wall at will. Formerly, Tyndall stone, was used for trim and decoration, particularly around individual windows. Here it is also used in conjunction with windows, but rather than serving to accentuate individual openings, it is used in the form of spandrel panels, to unify and define larger blocks of fenestration. Decoration is omitted, but large areas of window



Figure 4. Pink granite, Tyndall stone soffit and curtain wall glazing.



Figure 5. Maple wainscoting and door with steel knob.



Figure 6. Maple framed chalkboard.

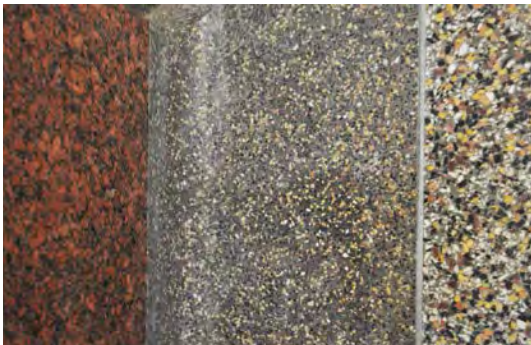

Figure 7. Pink granite wall and terrazzo flooring.

and wall are used as elements in a carefully designed composition. (For further information on building stones used at the U of S, refer to [‘Appendix: Stone.’](#))

Materials are also used in the design of the Murray Building to articulate and differentiate volumes as elements of a formal composition. For example, a large volume of smooth cut Tyndall stone turns the north-east corner, facing [‘The Bowl,’](#) to mark the main entrance (Figure 8). Large slabs of polished pink granite also highlight the entrance, which is accessed by a set of stone steps (Figures 2 & 4). The pink granite also extends past the glazed entry doors into the foyer. These intersections of volumes and extensions of materials are a common device within Modernism, which sought ways to use the innate characteristics of materials and shapes to express architectural ideas, rather than using applied decoration and symbols. The elevations of the 1955 Murray Building are particularly skillful in their design, and their principal materials - greystone, Tyndall stone and granite - are all character-defining materials.

The interior of the building has been substantially modified; however, some of the original materials remain. The areas with the greatest material commemorative integrity are on the third and fourth floor. These areas still retain their original maple doors, wainscoting and dado rails as shown in Figure 5. There are also original maple framed chalkboards on these floors (Figure 6) as well as some study coves, tables and chairs which will be discussed in later sections. The condition of the maple materials is excellent where it exists; on the upper floors of the library portion and in the Saskatchewan Archives space. Maple is a character-defining element of the Murray Building.

Flooring in the Murray Building originally consisted of either vinyl composite tile (VCT) or terrazzo. Both still exist sporadically throughout the building. The staircases have all retained their terrazzo landings. The existing terrazzo has a high degree of commemorative integrity and is a character-defining material (Figure 7).

2.2 Form & Style

The design of the Murray Building represents a radical change in the architecture of the University of Saskatchewan. Compare, for example, the modernist design of the Murray Library with the historicist approach taken with the design of the [Memorial Union Building](#); these two buildings, so different in character, are exact contemporaries. Modernist architecture is characterized generally by the removal of applied ornament in favour of an articulation of material qualities, the manipulation of form and



Figure 8. Architect's sketch of the Murray Building, 1954. Photo A-5962, retrieved from http://scaa.sk.ca/gallery/uofs_buildings/

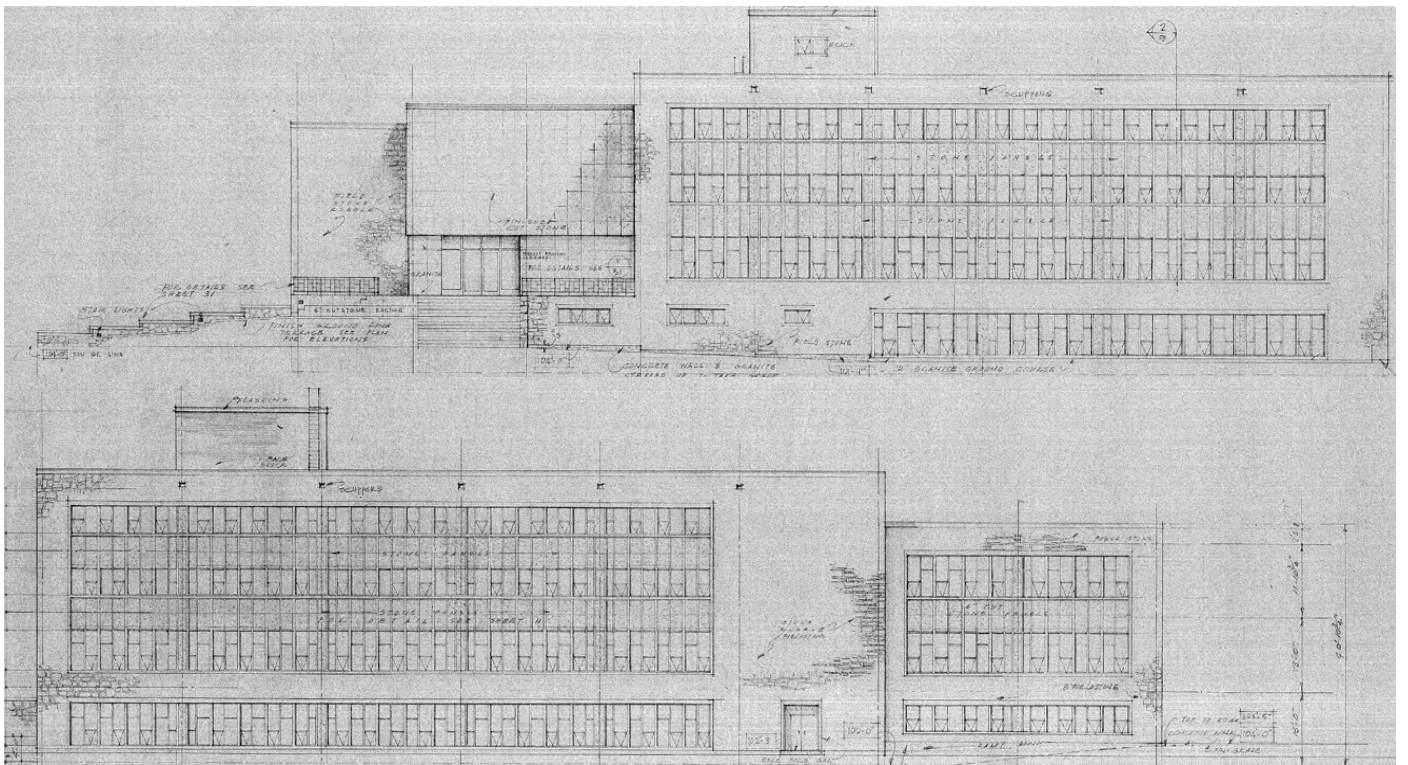

Figure 9. Elevations of the Murray Building. Retrieved from Facilities Management Division Asset Record System, File MM-52-T.



Figure 10. Alternating, repetitive window pattern.



Figure 11. Steel balustrade.

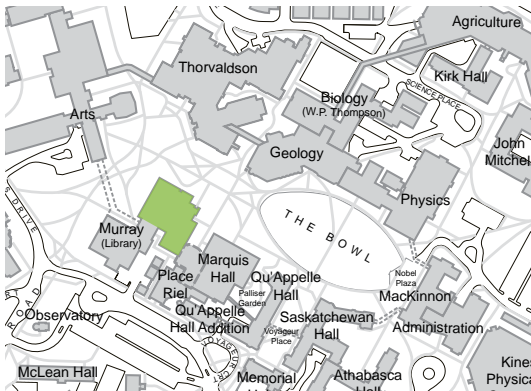

Figure 12. The Murray Building is indicated in green on this contemporary campus map.

the expression of function. Decorative elements tend to be abstract and geometric rather than figural or representational. The expression of material qualities and the formal composition of the building are discussed in Section 2.1 above.

Architects of the Modern period were interested in expanding the expressive range of forms, and this impulse led to designs that were no longer bound by conventions of symmetrical composition. The asymmetry of the Murray Building, in the arrangement of its forms and its elevations, is characteristic of the period. In form, the Murray Building is a composition of large rectilinear volumes. Figure 8 illustrates the play between a 4-storey greystone-clad volume on the north-west corner, intersecting with a three-storey volume to the south, mediated by the Tyndall stone entrance volume. The projections and intersections of these volumes are character-defining elements.

In elevation, the greystone, Tyndall stone and glazing are treated as discrete elements reinforcing the asymmetry of the form. The entrance volume is marked by large surfaces of smooth Tyndall stone, uninterrupted by windows except at the entry level. The entry is located at the corner, rather than in the centre of a wall as it generally was in earlier Collegiate Gothic buildings (Figure 9).

The design of the windows and the exterior steel balustrades that mimic them are examples of the abstract decoration typical of Modernist architecture of the period, and are character-defining features. The windows are functional elements, but through the alternating repetition of their frames, they take on a decorative quality. The design of the exterior hand railings repeats the same device (Figures 10 & 11).

Although the style of the building differs from those built earlier around [The Bowl](#), the scale of the Murray Building is in keeping with its surroundings. The scale of the building, at three to four storeys, is a character-defining element.

2.4 Location

The Murray Building is located on The Bowl, at its south-west end. As such, it is integral in shaping this prominent outdoor space (Figure 12). The 1972-74 addition to the building extended its floor plate south.

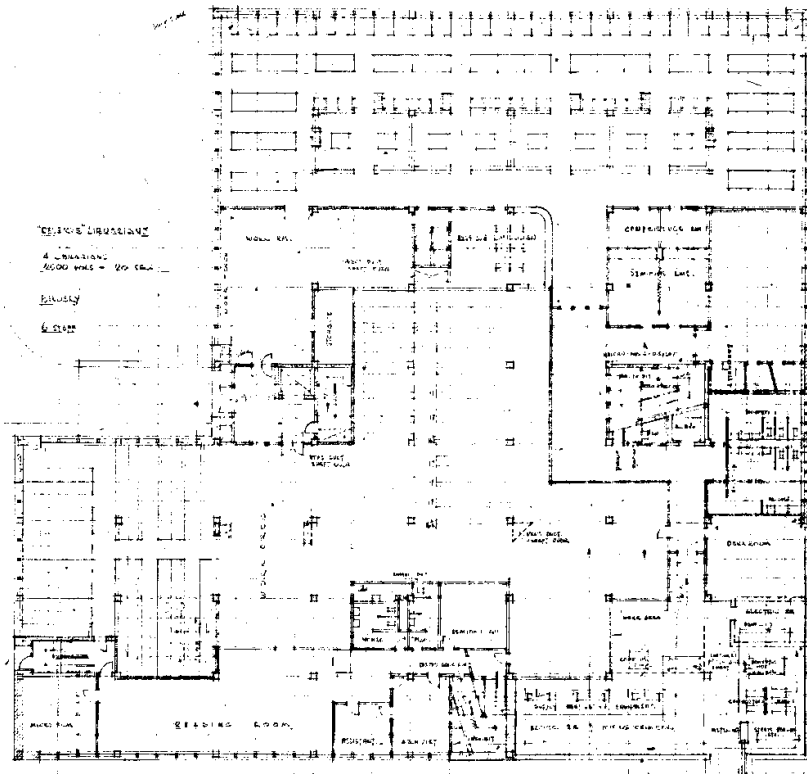

Figure 13. Ground floor plan. Retrieved from Facilities Management Division Asset Record System, File 053-4-T.

2.5 Spatial Configuration

Technological changes, such as the use of concrete and steel structures and the adoption of electric lighting, permitted changes in the form and spatial configuration of buildings, although sometimes these effects took several years to manifest themselves. The Murray Building illustrates one such change in its use of deep floor plates. Previously, buildings tended to have narrow floors permitting windows in most rooms. Artificial lighting allowed buildings to be designed with larger floor areas. As a large university library, the function of the building lent itself to this form; books could be stored in rows of stacks that did not require access to windows. The general spatial configuration suggested by this approach was for floors arranged with stack space at their core, and a ring of offices and study spaces around the perimeter. Larger floor plates also permitted larger rooms and open plan configurations. These configurations characterize the original design of the Murray Building (Figures 13-15).

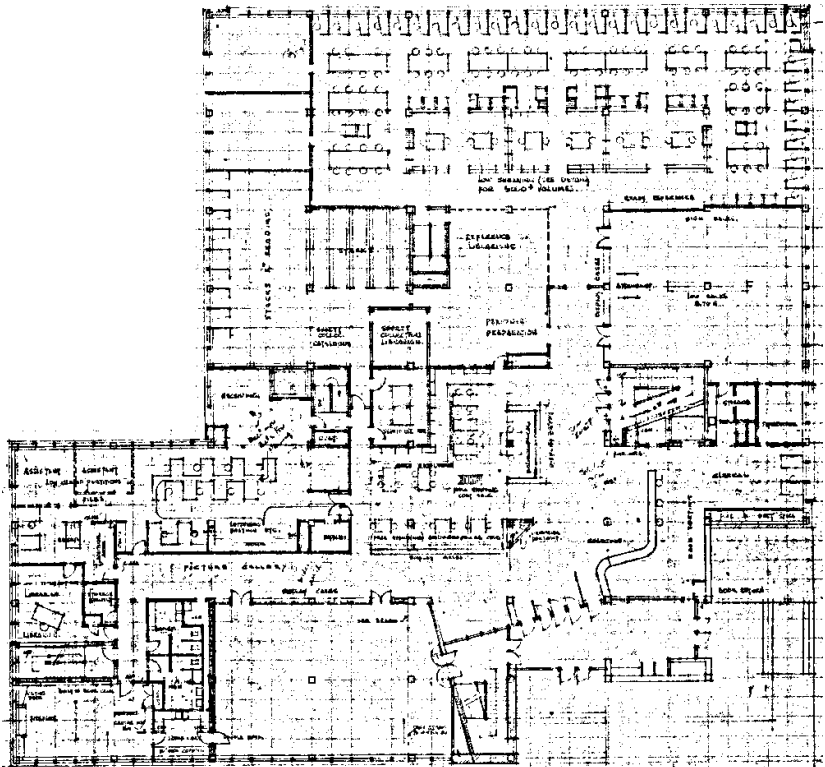

Figure 14. First floor plan. Retrieved from Facilities Management Division Asset Record System, File 053-3-T.

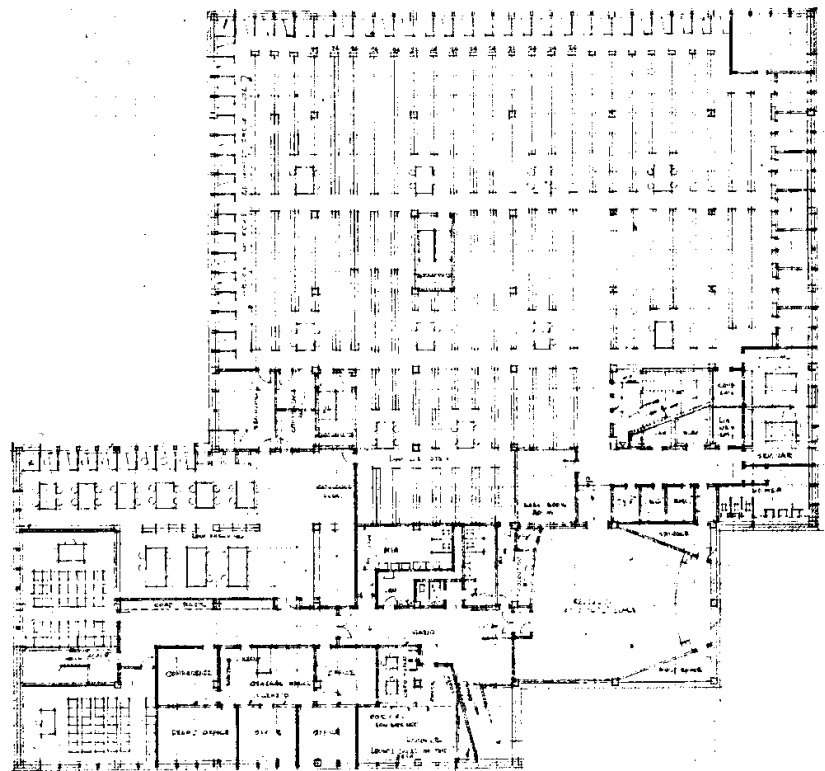

Figure 15. Second floor plan. Retrieved from Facilities Management Division Asset Record System, File 053-2-T.

The spatial configuration of the Murray Building has been significantly altered by numerous interior reconfigurations and its interiors maintain little heritage value. The layout of the building has been fragmented with the piecemeal allocation of parts of the building to library uses and parts to the Department of Art & Art History. The result has been a division of the building characterized by a lack of access and interconnection. Figures 16 through 18 show the results of the 1973 reconfiguration to accommodate the Arts Department in the building.

The Saskatchewan Archives is still located in the building's ground floor and retains its commemorative integrity. Its layout has scarcely been changed. Figure 13 shows the original ground floor plan with the archival space in the lower left.

All of the staircases are original to the building.

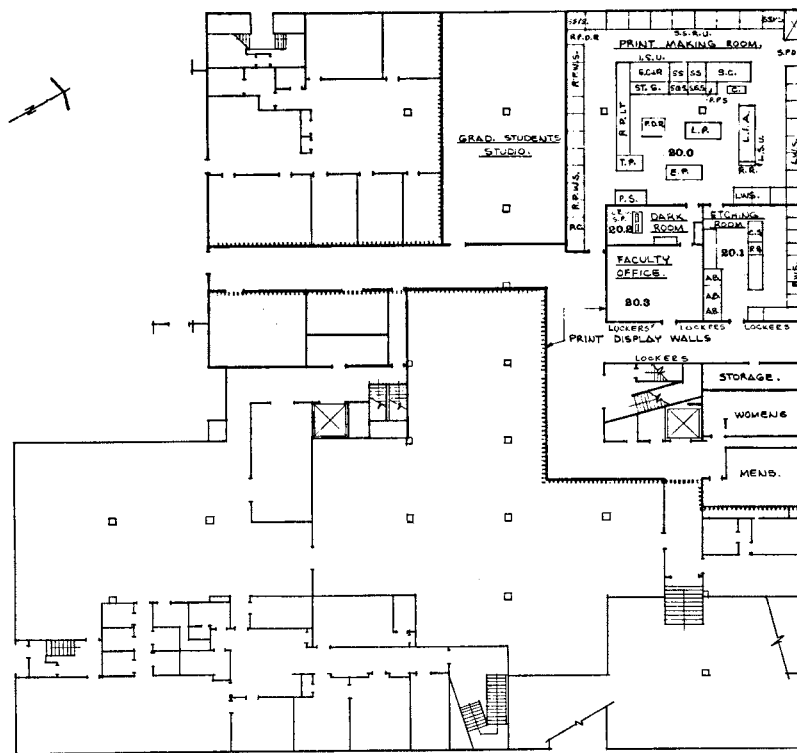

Figure 16. Ground floor plan after 1973 renovation. Retrieved from Facilities Management Division Asset Record System, File 053-512-T.



Figure 19. The steel structure of the Murray Building, winter 1954-1955. Photo A-597, retrieved from <http://sain.scaa.sk.ca/items/index.php/university-of-saskatchewan-archives;isdiah>



Figure 20. A student uses the library in the MacKinnon Building, 1940. Photo A-3427, retrieved from http://scaa.usask.ca/gallery/uofs_events/articles/1956.php

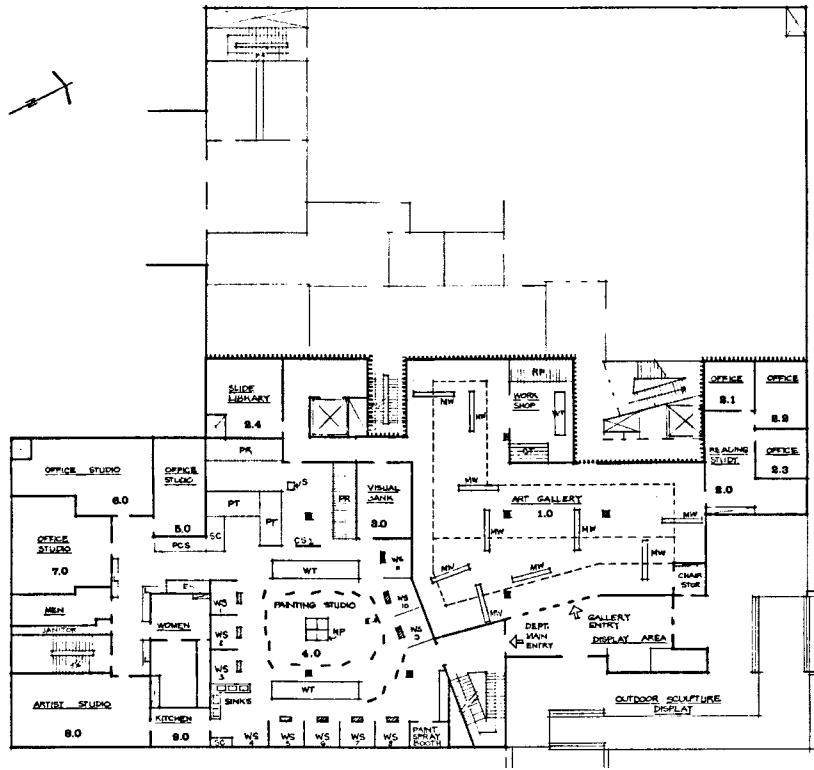

Figure 17. First floor plan after 1973 renovation. Retrieved from Facilities Management Division Asset Record System, File 053-511-T.

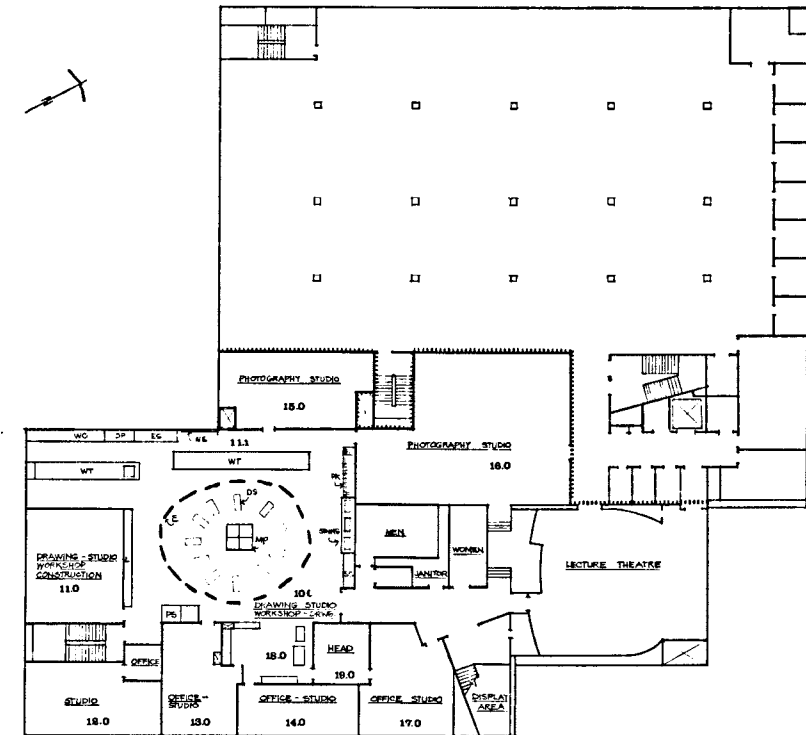

Figure 18. Second floor plan after 1973 renovation. Retrieved from Facilities Management Division Asset Record System, File 053-510-T.

2.6 Systems

Although steel structural elements had been used previously in conjunction with other structural systems, the Murray Building marks the first use of a complete steel structural frame at the University of Saskatchewan (Figure 19). Concrete floor slabs are supported by open web steel joists spanning between steel beams. The exterior greystone walls are a veneer, supported on steel angles fixed back to the steel structure. The stone is laid up against backing walls of cast-in-place concrete or clay tile, but the backing walls are supported by the steel frame.

Having been constructed as a library, the Murray Building's structural system also had to take into account the additional live load attributed to books. A myth circulates that the architects of the Murray Building failed to take into account the weight of the books in the building's design. In the 1970's students used this logic to explain why a new library was being built directly adjacent to the old one. In fact, the original drawings correctly note the required live load, and the building is structurally sound. The new library was built simply to accommodate the rapid growth of the university.

2.7 Use(s)

The Murray Building was the first purpose-built library at the University of Saskatchewan, although other buildings contained library collections prior to its construction. The first library collection was housed in the [MacKinnon Building](#) and other collections were held in smaller departmental libraries throughout the campus. Figure 20 shows the early library in the MacKinnon Building. The Murray Building was also built to accommodate the College of Law, the provincial archives and a 105 seat lecture theatre that was state of the art in its audiovisual provisions at the time. Figures 21 and 22 show the old library card catalogue and the Special Collections area. Figure 23 shows the Saskatchewan Archives.

Between 1972 and 1974 a new six floor building was added to the south side of the Murray Building and for a time became known as the Main Library. The Main Library took over many of the original functions of the Murray Building; the circulation desk and much of the book collection was moved into the new addition.



Figure 21. 1958, the Murray Building being used as a library. Photo A-649, retrieved from http://scaa.sk.ca/gallery/uofs_buildings/



Figure 22. Special Collections room, 1958. Photo A-640, retrieved from <http://sain.scaa.sk.ca/items/index.php/university-of-saskatchewan-archives;jsdiah>



Figure 23. Two archivists using the reading room at the office of the Saskatchewan Archives Board, 1960. Photo S-B6511, retrieved from <http://sabphotos.wordpress.com/>



Figure 24. Art studio in upper floor of the Murray Building's east side.



Figure 25. The unveiling of Walter Murray's portrait at the opening of the Murray Building (then the Murray Memorial Library), November 30, 1956. The portrait is currently located in the Administration Building. Photo A-605, retrieved from http://scaa.usask.ca/gallery/uofs_events/articles/1956.php

In the mid 1970's a series of renovations prepared the Murray Building for use by the Department of Art and Art History. This saw the division of the building between library and art department. The ground floor of the western portion and the second and third floors of the eastern portion came to be used for art education and exhibition (Figure 24). The use of the building for art and art history is not original, but it has been in place for almost forty years.

The consistent use of the Murray Building as a library is character-defining.

2.8 Cultural & Chronological Associations

The Murray Building can be associated with its namesake, the first president of the university, Walter Murray. Murray was appointed president in 1908 and remained in office until his retirement in 1937. He is well remembered for his vision of a 'people's university.' Walter Murray passed away in 1945. After his death, a memorial fund was set up in his name for the purpose of building a library, resulting in the construction of the Murray Memorial Library. Figure 25 illustrates the unveiling of Murray's portrait at the opening of the building.

The Murray Building can also be associated with the history of the library system at the University of Saskatchewan. The library began loaning books in 1909 from the second floor of the MacKinnon Building and expanded into small departmental libraries scattered across the university. As the first purpose-built library building, the Murray Building unified and consolidated the library system.

Arthur Silver Morton was the first university librarian and served in this capacity between 1914 and 1940. Morton was also the first provincial archivist from 1937 until 1945. He was instrumental in the decision to allocate space at the University of Saskatchewan to the Saskatchewan Archives Board.

Annie Maude (Nan) McKay, the first Métis and first Aboriginal woman to graduate from the University of Saskatchewan, worked as Assistant Librarian at the University Library between 1915 and 59 (Figure 28).

The third of five children, Nan was born October 10, 1892, at Fort à la Corne, Northwest Territories to an English Métis family. In 1912, she won a \$200 entrance scholarship, which enabled her to attend the university. Nan took a very active part in student life at the university, working on The Sheaf student newspaper, serving as a member of the Students Representative Council's (SRC) executive committee, as secretary of the campus YWCA and as secretary of the Literary Society. She also played ice hockey

for university teams. After graduating, she served the assistant librarian at the University Library until 1959. She died on July 27, 1986, at the age of 93.

3. Associated Objects

The Murray Building has retained much of its original furniture. Maple chairs and tables are still used throughout the building and the addition.

Two plaques on the Murray Building honor Walter Murray, and Arthur Silver Morton (Figures 26 & 27).

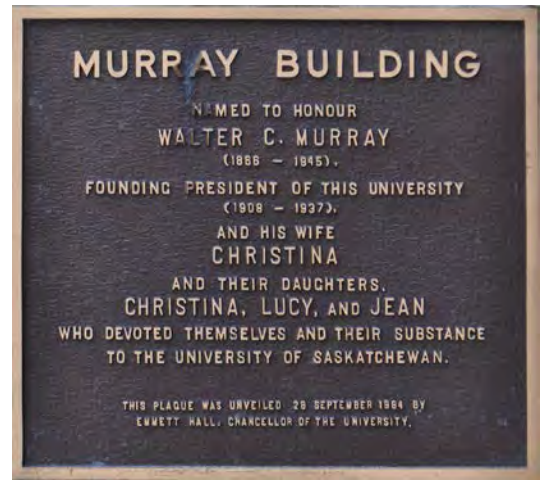

Figure 26. Plaque dedicated to Walter Murray and family.

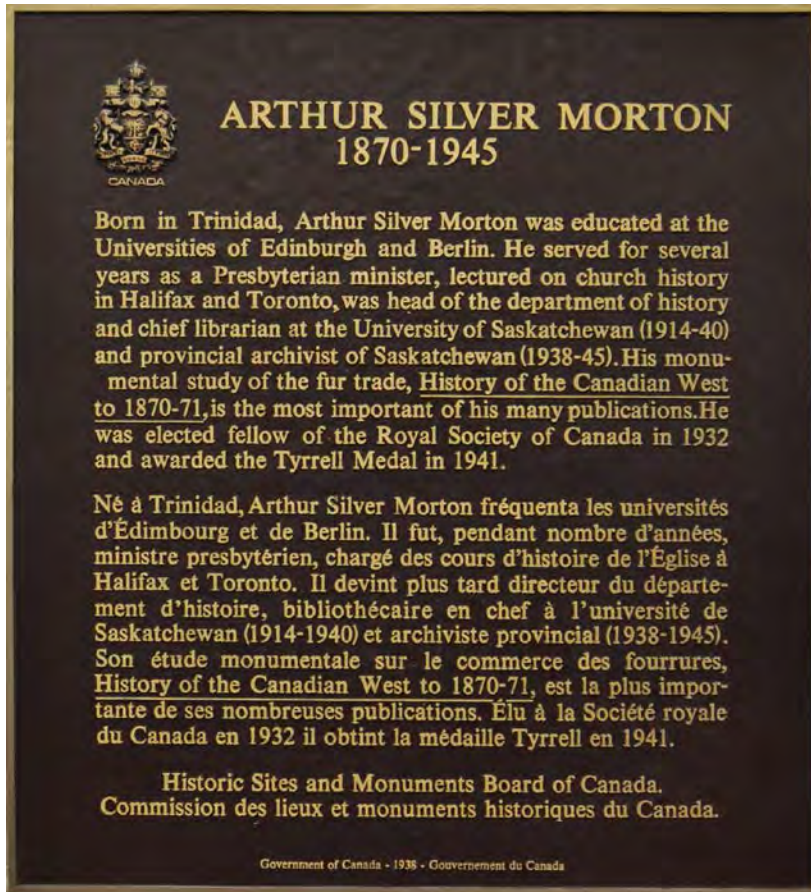

Figure 27. Plaque dedicated to Arthur Silver Morton.



Figure 28. Annie (Nan) McKay, first Aboriginal woman graduate of the university, and Assistant Librarian from 1915 to 1959. (Image: University of Saskatchewan Library).

4. Supporting Documents

Kerr, D. (1980). Building the University of Saskatchewan 1907-1930. *Prairie Forum*, 5(2), 157-181.

Hayes, P. (March 18, 2005). From the University Archives 'U Museum' Idea Has Long History. *On Campus News* 12(14). Retrieved from http://news.usask.ca/archived/ocn/05-mar-18/column_archives.shtml

University of Saskatchewan Archives. (Retrieved 2012). *Events in the History of the University of Saskatchewan 1956: Murray Memorial Library Opens*. Retrieved from http://scaa.usask.ca/gallery/uofs_events/articles/1956.php

University of Saskatchewan Archives. Presidential Papers Series III. B-116. Library (1950-1959) RG 1 S3.

Vajcner, M., (Retrieved 2012). *The encyclopedia of Saskatchewan, Morton, Arthur Silver (1870-1945)*. Retrieved from http://esask.uregina.ca/entry/mortonarthur_silver_1870-1945.html

Warden, K. (Retrieved 2012). *Campus Myths Add Spice for First-Year Students*. Retrieved from www.brainsugar.com/media/UofSCampusMyths.doc



5. Summary of Character - Defining Elements

Materials

- greystone walls
- Tyndall stone trim, spandrel panels and soffit
- granite wall panels
- maple doors and surrounds
- terrazzo flooring
- expansive glazing

Form & Style

- planar facades
- large cubic volumes
- asymmetrical composition
- intersecting volumes and materials
- lack of ornamentation
- repetition of elements, such as windows
- alternating pattern of window frames, used as a decorative element

Location

- the Bowl

Spatial Configuration

- deep floor plates
- open plan library stacks
- study rooms and coves
- lecture theatre
- Saskatchewan Archives
- staircases

Uses

- library
- College of Law
- Saskatchewan Archives
- art education, practice and display

Cultural & Chronological Associations

- President Walter Murray
- History of the U of S library system
- Arthur Silver Morton, first librarian



054

Peter MacKinnon Building



054

Peter MacKinnon Building

Alternate Names

The College of Agriculture Building
Administration Building
'Old' Administration Building
College Building

Architect(s)

**David R. Brown and Hugh Vallance, Brown and Vallance
Architects, Montreal**

Builders

Smith Brothers & Wilson General Contractors

Construction Dates

1910-1913

Recognition

**National Historic Site of Canada, Government of Canada
Historic Sites & Monuments Act, Designated 2001**
**Provincial Heritage Property, Government of Saskatchewan,
Heritage Property Act, Designated 1982**
University of Saskatchewan 'A' Listed

1. Statement of Significance

The Peter MacKinnon Building, formerly named the College Building, is a highly significant heritage building at the University of Saskatchewan, constructed between 1910 and 1913. It is the centrepiece of a collection of original stone buildings located around [‘The Bowl’](#), a large courtyard that forms the heart of the campus. The [Canadian Register of Historic Places](#) has called this group of buildings “the finest collection of Collegiate Gothic university buildings in Canada.” The MacKinnon Building was one of the first five buildings commissioned by the new university in 1909 and put out to tender in the spring of 1910. Designed by the architectural firm of David Brown and Hugh Vallance of Montreal, the MacKinnon



Figure 1. The Mackinnon Building, ca.1912. A horse and buggy are visible in front of the building. Photo A-26, retrieved from University of Saskatchewan Archives.

Building was the first on campus to begin construction, but not the first to be finished, opening in May 1913.

The MacKinnon Building has heritage value as an excellent example of Collegiate Gothic architecture. The exterior of the building maintains a high degree of integrity. Although the newer [Administration Building](#) partially obscures its east side, the front elevation of the MacKinnon Building, which faces The Bowl, is very well preserved. The interior of the MacKinnon Building, aside from its corridors and public spaces, has undergone many changes since its construction. In 1997, the MacKinnon building was condemned due to structural failure, and was extensively renovated and restored between late 2003 and 2005. During these renovations, the partitions between rooms were removed, but the public spaces of the building - the main corridors, the principal staircases, and Convocation Hall - were restored in place and retain a high degree of commemorative integrity.

The MacKinnon Building also has heritage value in its status as the first College of Agriculture at a Canadian university. Although the MacKinnon Building initially accommodated all academic disciplines at the university, its lecture halls, classrooms, laboratories and offices were designed primarily to house the College of Agriculture. Previously, formal agricultural education in Canada had been conducted at agricultural colleges with only nominal connections to universities. The University of Saskatchewan was the first in Canada to establish an agricultural college on its main campus. Understanding the importance of agriculture to the development of the province, the University of Saskatchewan gave the College of Agriculture a professional status equal to the more traditional colleges, such as the Liberal Arts and Sciences, Medicine, and Law.



Figure 2. Corner made of limestone with greystone on either side, on a base course of granite.



Figure 3. Slate tile roofing.



Figure 4. Stone with efflorescence.



Figure 5. L to R: Steel window frame and fixture with oak sill.

The MacKinnon Building was designated a Provincial Heritage Property on November 24, 1982 and a National Historic site in February 2001.

Note: The MacKinnon Building is configured with floors numbered Ground Floor, First Floor, and Second Floor. This report follows the same convention.

2. Character - Defining Elements

2.1 Materials

The MacKinnon Building was constructed of high quality materials, most of which remain in an excellent state of commemorative integrity (Figures 2 & 3). Its exterior was built largely of the locally-sourced dolomitic limestone commonly referred to as 'greystone'. The base of the building is supported by granite of a light grey color with black flecks. The building's arches, architraves, crenellation, quoining and other stone ornamentation are all fashioned out of Bedford or Indiana limestone. (For further information on building stones used at the U of S, refer to '[Appendix: Stone](#).') The roof of the MacKinnon Building is clad in slate tile with copper flashing, gutters and downspouts.

Portions of the original exterior stone walls are now enclosed within the [Administration Building](#), which was added to the east of the MacKinnon Building. Some of the enclosed stone shows white residue or efflorescence as shown in Figure 4. Aside from this, the building's stone is in excellent commemorative condition.

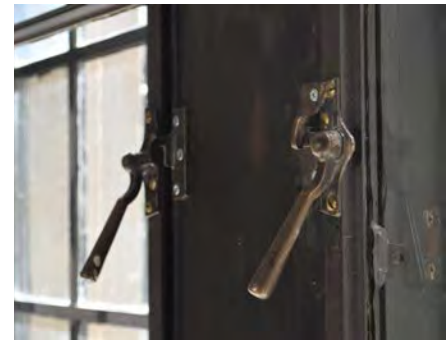

Figure 6. Bronze window hardware in the MacKinnon Building's Convocation Hall.

The public spaces on the interior of the MacKinnon Building, such as its corridors, stairwells and the lecture theatre called Convocation Hall, have been preserved and restored. Among the building's interior features are arched doors and door surrounds of stained quarter sawn oak, with bronze and steel hardware. Some oak baseboards remain while some have been replaced in kind. Window frames are steel and in many cases windows retain the original panes of glass. In some cases, new aluminum-framed windows have been added to the interior side of original window openings for increased thermal performance. Some windows have bronze hardware and oak surrounds. Figure 5 shows a steel-framed window, with an oak surround and bronze hardware.

In the corridors and stairwells, walls are finished in a glazed terracotta tile made to resemble stone. Floors are finished in slate and clay tile (Figure 7). Stair cases have steel stringers, cast iron risers, slate treads and painted steel and cast iron balusters with oak handrails (Figures 8 & 9). The slate stair treads are original and have been worn down from years of use (Figure 9). Throughout the building, original fixtures such as cast iron radiators and steel standpipes have been maintained (Figure 10).

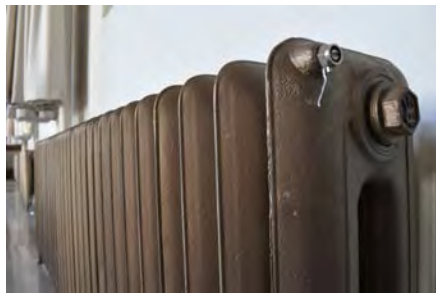

Figure 10. Cast iron radiator, plated in bronze.

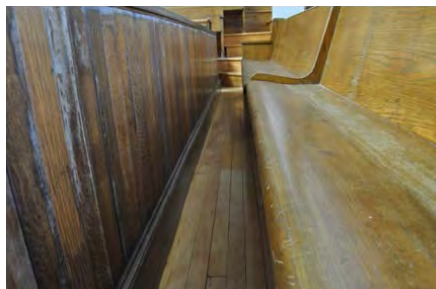

Figure 11. L to R: Original oak balcony, hardwood flooring and wooden seats.

Convocation Hall is a large ceremonial assembly space forming the centrepiece of the MacKinnon Building. All of the wood and steel windows in Convocation Hall are original. Original plaster walls including its two arcaded aisles, have been restored. A large skylight was uncovered during the renovation work and was re-established. Minor changes have been made to the stage, ceiling, and floors. The lighting fixtures are not original, but are remnants of a later renovation. The balcony level in Convocation Hall has an original oak baluster, seating pews and floor. These original wooden features are shown in Figure 11.



Figure 7. Top to bottom: terracotta wall and base, slate and day tile floor.

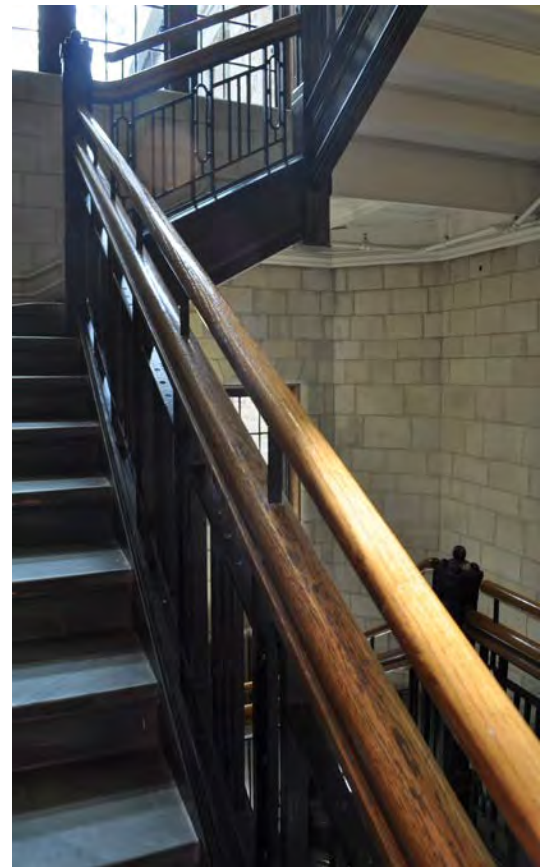

Figure 8. L to R: Slate Stairs, steel stringers, wooden handrails.

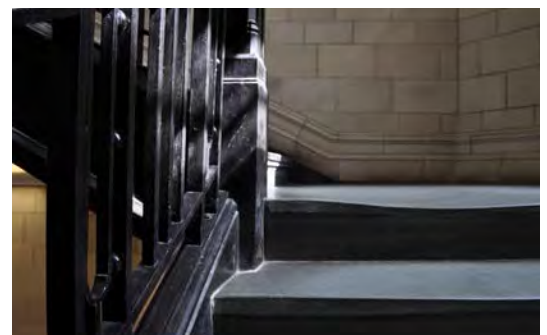

Figure 9. Slate stair treads.

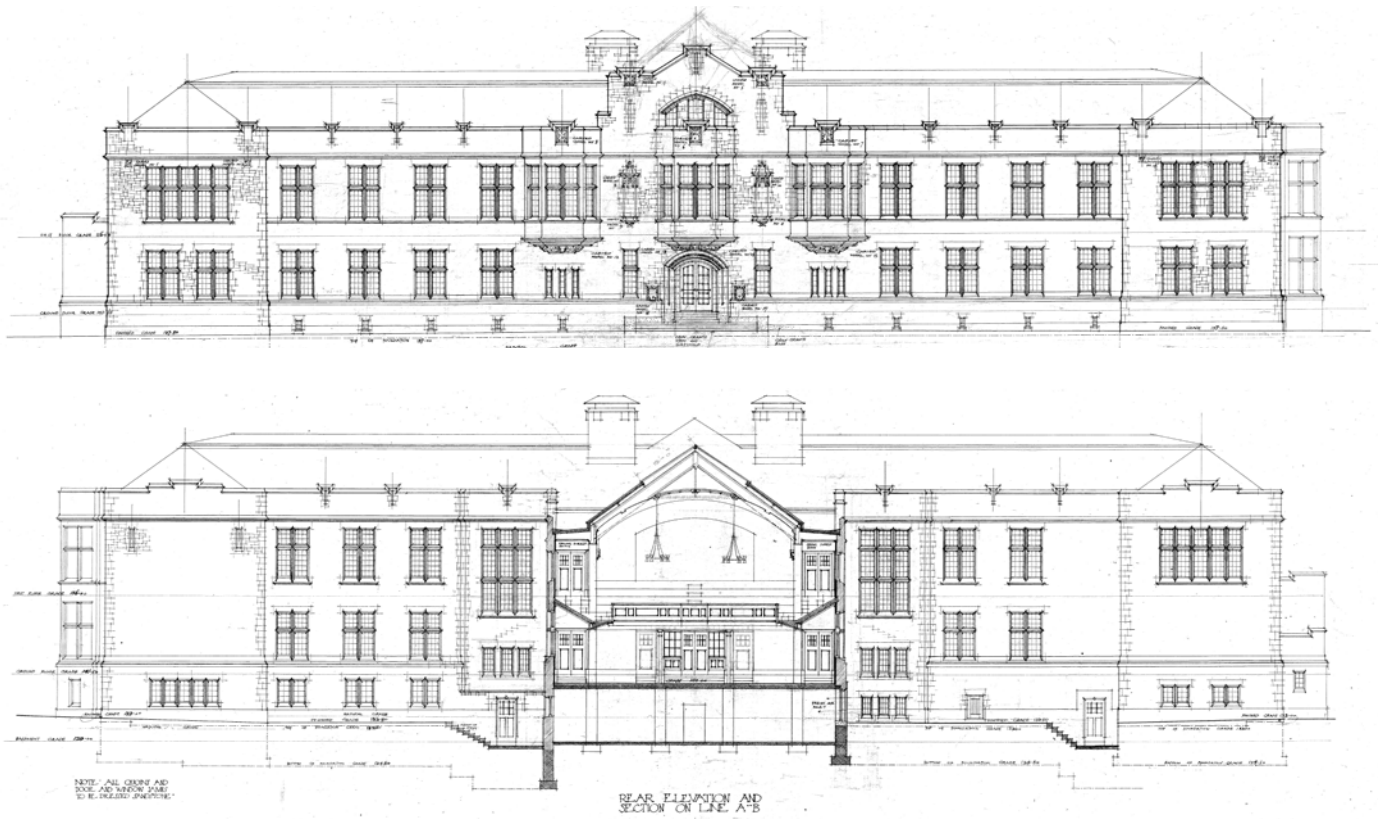

Figure 12. Front and rear elevations of the MacKinnon Building by Montreal Architects David R. Brown and Hugh Vallance show the long, low massing that came to define campus buildings. Retrieved from Facilities Management Division Asset Record System, File A-B-6T.



Figure 13. Oriel windows adorn the facade of the MacKinnon Building.

2.2 Form

The MacKinnon Building is E-shaped in plan, and two and a half storeys in height, with hipped roofs. It has a finished basement and an unoccupied attic space. Its long front elevation faces west onto the bowl, and is symmetrical in composition (Figure 12). The narrow floor plan and relatively low overall height of the MacKinnon Building are character-defining elements. These characteristics are typical of early buildings at the University of Saskatchewan and reflect the 1909 Campus Plan. Its two and a half storey height is in keeping with the other buildings on campus built around the same time. Between 1985 and 1987, the [Administration Building](#) (Weins and Johnstone Architects), was built as an addition to the MacKinnon Building. This changed the form of the MacKinnon Building, but a discussion of the addition is outside of the scope of this report.

2.3 Style

Collegiate Gothic was the architectural style adopted by the University of Saskatchewan during its early stages of development, prior to the Second World War. Collegiate Gothic was a branch of the Gothic Revival movement of the 19th and early 20th centuries, which sought to re-establish principles of mediaeval art and architecture. The Collegiate Gothic style was used to associate newer North American universities with the history and traditions of their ancient European predecessors.

Several elements define the Collegiate Gothic style employed on the MacKinnon Building and are character-defining elements. The building's front façade is symmetrical in composition. The main entrance forms the central element in the design, marked by a pedimented bay and a row of three large oriel windows in the second floor (Figures 12 & 13). Statuary niches, visible in Figure 14, flank the central oriel window. Figure 15 shows the main entry, recessed within a shallow vault and featuring an arched oak door. The use of the arch, particularly the pointed or gothic arch, is a typical feature of the Collegiate Gothic style. The roofline features a crenelated parapet (Figure 14), another common feature of Collegiate Gothic buildings. Quoining – the visual emphasis of the exterior corners of the stone walls - is visible in Figure 17.

Carved stone ornamentation is an important feature of the Collegiate Gothic style. Walter Murray, the university's first president, requested the depiction of local fauna, such as gophers, ducks, and prairie chickens, in the carved stonework (Figure 18 & 19). However, the stone masons brought in from eastern Canada to carry out this work were unfamiliar with these animals. They expressed their frustration in the scenes they chose to depict; one gargoyle is seen wielding a mason's hammer

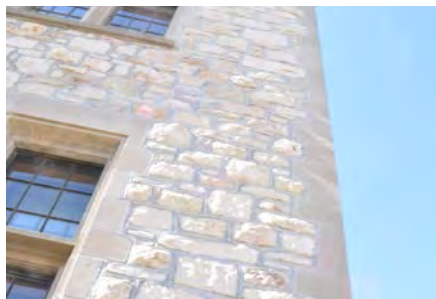

Figure 17. Sandstone quoining.

in one hand and a prairie chicken in the other, with a pained look on his face (Figure 19). Some of the depictions of Saskatchewan creatures, such as the gopher, are inaccurately rendered. Other more standard decorative motifs include acorns, oak leaves and ivy.



Figure 14. Crenellation along the roofline and an oriel window and statuary niche on the left.



Figure 15. The MacKinnon Building's principle entry recessed within an arch, featuring an arched door.



Figure 16. Stone corbels and string course.



Figure 19. A frustrated gargoyle threatens a prairie chicken with a mason's hammer.



Figure 20. Interior arched entries and transoms surrounded by a terracotta wainscot under a vault ceiling.

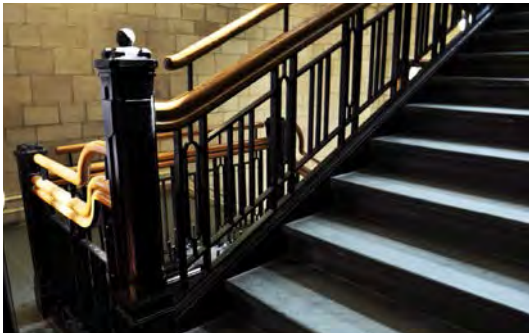

Figure 21. Ornamented balustrade.

The interior of the MacKinnon Building also contains Collegiate Gothic character-defining elements. The corridors feature arched oak doors and transoms, vaulted plaster ceilings and terra cotta wainscot. Many of these interior character-defining stylistic elements are shown in Figure 20 and exist in excellent commemorative condition. The two main staircases are character-defining elements for the level of decorative detail incorporated into their balustrades (Figure 21). The vaulted ceiling and arcaded aisles of Convocation Hall are also character-defining elements of both style and spatial configuration.



Figure 18. Heraldry in the form of a duck perched atop the Saskatchewan crest grounds the building in the local context.



Figure 22. Vaulted ceiling with skylights and accompanying arches in Convocation Hall.

2.4 Location

The MacKinnon Building is located prominently, at the head of The Bowl, and at the termination of the principal axis of the 1909 Campus Plan (Figure 23). It is flanked by the [Physics Building](#) and the student residences. The location of the MacKinnon Building reflects its importance as the intended home of the College of Agriculture. Agricultural education was of critical importance to the University of Saskatchewan, and this was the first agricultural college in Canada to be established as an integral part of a university. The location of the MacKinnon Building also helps to form the outdoor spaces around it, particularly The Bowl, which were an important aspect of the 1909 Campus Plan. (Refer also to the Heritage Register report on [The Bowl](#)).

2.5 Spatial Configuration

The MacKinnon Building's narrow interior layout and double-loaded corridors reflect common building practices at the turn of the 20th century (Figure 24). As electric lighting was still relatively new in 1909, the MacKinnon Building was designed with a large number of windows and a narrow footprint, allowing the deep penetration of natural light. Double height windows in stairwells and other public spaces are also character-defining. The skylight in Convocation Hall is another way in which the building was designed to take advantage of natural light (Figure 22). Convocation Hall is a grand, double height space with a vaulted ceiling and large balcony. The proportions of the space and its stylistic elements make it a character-defining space.



Figure 23. The location of the College Building is indicated in green on the 1909 Campus Plan by Brown and Vallance. North is to the left.

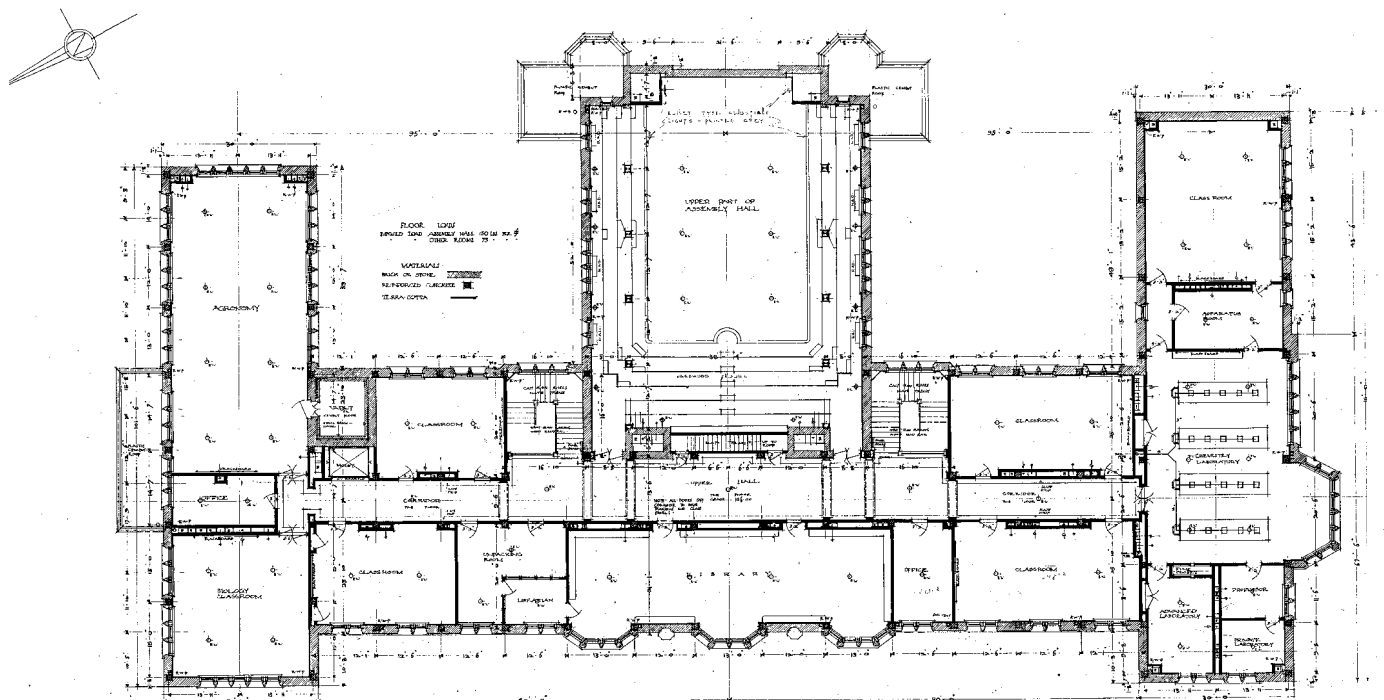

Figure 24. Original second floor plan of the MacKinnon Building revealing narrow floor plate, double loaded corridors and original uses. Retrieved from Facilities Management Division Asset Record System, File A-B-4T.

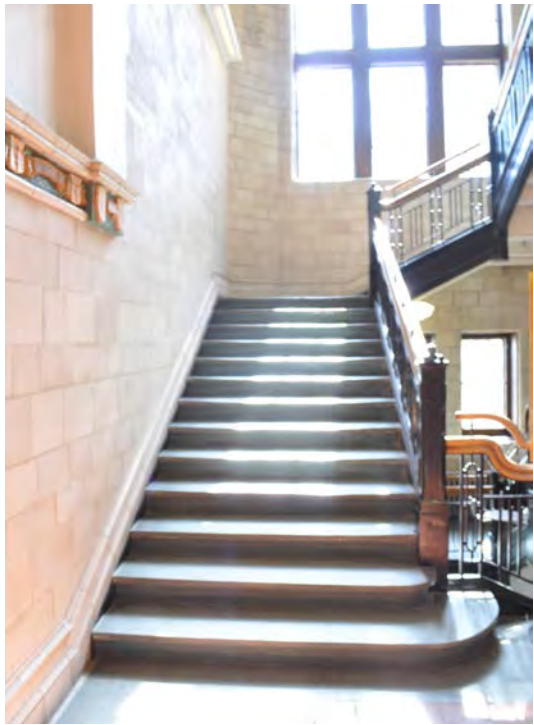

Figure 25. Public spaces have ample natural light due to the amount of glazing and the narrow floorplan.



Figure 26. Vault door.

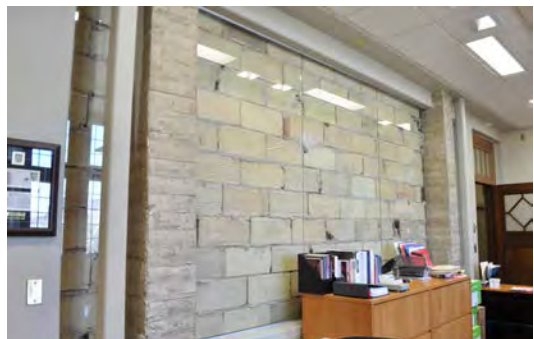

Figure 27. A portion of the concrete structure revealed.

The building's original configuration has been well preserved although some changes have been made over time. The addition of the [Administration Building](#) in 1987 had altered the flow of pedestrian traffic through the building and has enclosed some exterior walls. The basement has also seen significant change with its conversion into an underground tunnel connecting to the adjacent residences and [Physics Building](#). The original basement windows has all been filled in, removing much of the natural light from the space.

An elevator was added to the north end of the building during the 2003-2005 restoration. The elevator shaft takes up the space of an old vault on the first and second floors. Although they are non-functioning, the vault doors (Figure 26) remain embedded in the walls. Their presence as a trace of the history of the building is a character-defining element.

2.6 Systems

The MacKinnon Building was built with a cast-in-place concrete frame, supporting concrete floor slabs and a roof structure consisting of wood decking on a system of steel beams and trusses. At the time of its construction, concrete was still a new technology and its application was not well understood. The poor design and execution of the concrete frame and floor structures revealed themselves in later years, and structural failures forced the closure of the building in 1997. Subsequently, the MacKinnon Building was extensively restored.

The building's original structure, including its failed components, have been reinforced by a new secondary steel structure, but have been retained for commemorative purposes and are displayed throughout the building. The presidential suite contains three 'windows' – where aspects of the original structure have been preserved and displayed behind glass. Many more are found in the southern wing and an old electrical box is preserved in the north. Figure 27 shows a section of the original concrete structure displayed within the President's office suite. The ceiling of the University Art Collection space has been left entirely exposed in order to leave the original ceiling and construction practices of the period visible.

The building's corridors have retained the old fire hose carriers, which are longer functional but have been retained for commemorative purposes (Figure 28).



Figure 28. Non - functioning fire hose carrier.



Figure 29. The library, originally housed in the MacKinnon Building, where the presidential suite now exists, ca. 1940. Photo A-3425, retrieved from http://scaa.sk.ca/gallery/uofs_buildings/

2.7 Use(s)

The MacKinnon Building was originally intended to house the College of Agriculture; however, initially, all of the academic functions of the university were contained within this building. Over time, it gradually became to be used primarily as an administrative office building. As early as April 1910, the floor plan included space for milk testing, butter making and cheese ripening on the ground floor. A gymnasium, several classrooms, offices for the Registrar, Dean of Agriculture, Director of Extension, and President, the original “faculty club”, laboratories, the library and quarters for the janitor were other early uses. Figures 29 and 30 are photographs of some of the building’s historic uses. Before the construction of the [Murray Library](#) in 1955, the University Library was housed in the MacKinnon Building in what currently serves as the presidential suite (Figure 29). The university’s first chemistry lab was housed in the basement.

In addition to Convocation Hall, the MacKinnon Building began its life containing both classrooms and offices, but later evolved to become primarily an administrative centre. By the 1950s, most of the original teaching facilities in the MacKinnon Building were taken over by new or expanded offices including those of the Registrar, Controller, alumni and news services, and the President’s staff. The building became known as the Administration Building.



Figure 30. The original chemistry lab, located in the basement of the MacKinnon Building, 1913. Photo A-2602, retrieved from http://scaa.sk.ca/gallery/uofs_buildings/



Figure 31. Students registering for classes in Convocation Hall, 1960. Photo A-2276, retrieved from http://scaa.sk.ca/gallery/uofs_buildings/



Figure 32. The University Choral Society and Saskatoon Symphony Orchestra perform in Convocation Hall, ca. 1936. Photo A-2142, retrieved from http://scaa.sk.ca/gallery/uofs_buildings/



Figure 33. Located in the buildings southwest corner, the Museum of Antiquities now sits where classrooms were originally located.



Figure 34. Enclosed in the corner stone were, among other items, a copy of the University Act; pamphlets on the university and city; photos of university officials; psalms, hymns, a Bible and a copy of Pilgrim's Progress in Cree; specimens of grain; and a telephone directory. Photo A-3072, retrieved from http://scaa.sk.ca/gallery/uofs_buildings/



Figure 35. Prime Minister Wilfrid Laurier, at the ceremony to lay the cornerstone for the College Building, July 1910. Photo A-8, retrieved from http://scaa.sk.ca/gallery/uofs_buildings/

Convocation Hall is an original feature of the MacKinnon Building, which was included in the design brief at the suggestion of Dean W.J. Rutherford of the College of Agriculture, in order to house farmer's meetings. Upon its completion, this assembly space sat 600 and was also used as a venue for ceremonies. The space was also used for lectures, meetings, performances, exams, registration, and convocation ceremonies. Figures 31 and 32 show some of the various functions it has served. By 1930, the University had outgrown the hall as a venue for convocation. However, it maintained its original, broader function as a hall for meetings, concerts, lectures, and other events.

In 1979 parts of the building were declared to be unsafe due to structural problems. Most of the building was closed after the completion of the new Administration Building in 1987. Convocation Hall, however, remained in use until 1997.

In 2005 the building reopened its doors after undergoing extensive restoration and was renamed the College Building. The presidential suite was moved back to the College Building from the [Administration Building](#) where it had been residing since that building's opening. The current boardroom was built in the original location of the chemistry lab. In addition to senior administrative offices and Convocation Hall, the MacKinnon Building became home to the Museum of Antiquities (pictured in Figure 33) and a new gallery space for the University Art Collection. These spaces were originally home to the machinery room.

2.8 Cultural & Chronological Associations

In 1913, the construction of the MacKinnon Building signified the establishment of Saskatchewan's first university, and today it reveals issues considered important to society at that time. Its cornerstone was laid by Prime Minister Sir Wilfrid Laurier, on July 29, 1910. The cornerstone is a character-defining element associating the MacKinnon Building with the national context in which it was built. Figures 34 and 35 show the cornerstone and the ceremony during which it was laid.

The MacKinnon building is notable as the first College of Agriculture to be included within a university rather than as a separate entity. Its prominent location reflected the importance of agricultural education to the university's founders. (See Section 2.4).

The MacKinnon Building is associated with the University of Saskatchewan's first president, Walter Murray. Murray's office was located in the building and he had great influence over its design and construction. Murray selected the Collegiate Gothic style as an appropriate architectural expression of the ideals



Figure 39. Volunteer nurses during the influenza epidemic of 1918 commemorated on the walls of the MacKinnon Building.

of the new university and chose Brown and Vallance to realise this vision.

The building is associated with the university's place in some of the significant events of Canadian history. Its interior halls have a wainscoting of terra cotta tile, with a frieze on which the names of all the students, faculty and staff who fought in the First World War have been inscribed. This 'Honour Roll' situates the building within the international historical context of its time (Figure 36). Notably, John G. Diefenbaker, who went on to become Canada's 13th Prime Minister, is

commemorated on the banner (Figure 37). In a similar fashion, a terracotta engraving commemorates those who volunteered as nurses during the influenza pandemic of 1918 (Figure 39).

One of the volunteer nurses during the 1918 influenza outbreak was Annie Maude (Nan) McKay (BA'15), who was also the first Métis and first Aboriginal woman to graduate from the University of Saskatchewan (Figure 38). She also worked as Assistant Librarian at the University Library for 44 years (1915–59).

The third of five children, Nan was born October 10, 1892, at Fort à la Corne, Northwest Territories to an English Métis family. In 1912, she won a \$200 entrance scholarship, which enabled her to attend the university. Nan took a very active part in student life at the university, working on *The Sheaf* student newspaper, serving as a member of the Students Representative Council's (SRC) executive committee, as secretary of the campus YWCA and as secretary of the Literary Society. She also played ice hockey for university teams. After graduating, she served the assistant librarian at the University Library until 1959.

Nan McKay died on July 27, 1986, at the age of 93.

The MacKinnon Building can further be associated with its namesake. Peter MacKinnon was the eighth president of the University of Saskatchewan, serving from 1999 to 2012. The renovation and reopening of the building was undertaken under his presidency. For this and his legacy of leadership, the building rededicated in his honour in 2012.



Figure 36. 'Honour Roll' naming the students, faculty and staff who served in the First World War.



Figure 37. John G. Diefenbaker's name on the 'Honour Roll' on the building's second floor.



Figure 38. Annie (Nan) McKay, first Aboriginal woman graduate of the university, and Assistant Librarian from 1915 to 1959. (Image: University of Saskatchewan Library).

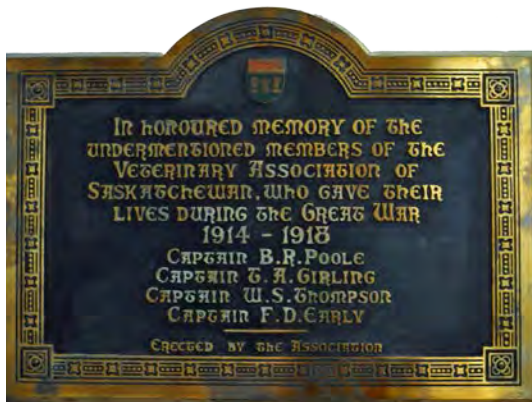

Figure 40. Top to Bottom: A plaque honouring members of the Veterinary Association who gave their lives during the First World War, a plaque remembering William George Hamilton who gave his life as a student nurse during the influenza epidemic of 1918, a plaque marking the location of the first Saskatchewan Agricultural Graduates Association.

Figure 41. Clockwise from top left: A plaque remembering the College of Home Economics, a plaque recognizing 100 years of the U of S Alumni Association, a plaque honouring Joseph Procter's donation of 560 hectares to the University of Saskatchewan, a plaque designating the building as a Provincial Heritage Property.

3. Associated Objects

A number of commemorative plaques are found on the walls of the MacKinnon Building. Inside Convocation Hall, a collection of brass plaques commemorate various people, groups and events associated with the university. The older plaques honour students and faculty who were killed during the First World War and the influenza pandemic of 1918 (Figures 40 & 41).

The 'Convocation Moose' hung inside Convocation Hall from 1925 until 2004 (Figure 42). The moose was a gift to the University of Saskatchewan from Dr. T.A. Patrick of Yorkton. During the renovation of the MacKinnon Building, the moose was moved to the lounge in [Saskatchewan Hall](#).

The board room on the second floor of the MacKinnon's Building's south wing contains portraits of all of the past Chancellors of the University of Saskatchewan. The earliest one is of Sir Frederick Haultain (Figure 44). The collection also contains a painting of former Prime Minister John G. Diefenbaker.



4. Supporting Documents

Author Unknown. (October 7, 2005). Moose Moves into Residence. *On Campus News*, 13(4). Retrieved from http://news.usask.ca/archived_ocn/05-oct-07/news02.shtml

Brown, D. (1924). The University of Saskatchewan, Saskatoon. *The Journal Royal Architectural Institute of Canada*, Oct.-Dec., 109-121.

Culture, Youth and Recreation Saskatchewan. (2003). *Provincial Heritage Property Information Kit for the College Building*, U of S., Saskatoon.

Facilities Management Division (2011). Asset Record System [Data File]. Retrieved from <\\usask\fmddfs\files\iis\IIS Public\ARS>

Hanson, S. (1985). The Administration Building. *Saskatoon History*, 3, 4-10.

Hayden, M. (1983). *Seeking a Balance: The University of Saskatchewan 1907-1982*. Vancouver: University of British Columbia Press.

Hayden, M. (2006). Why Are All Those Names on the Wall? The University of Saskatchewan and World War I. *Saskatchewan History*, 58 (2), 4-14.

Murray, D.R. & Murray, R.A. (1984). *The Prairie Builder: Walter Murray of Saskatchewan*. Edmonton: NeWest Press.

Mysyk, W.K. & Kulyk, C.L. (2006). *Saskatoon's Stone*. Saskatoon: Houghton Boston Printers & Lithographers Ltd.

Penny, C. (2003). *Commemorative Integrity Statement College Building (Uof S) National Historic Site of Canada* DRAFT STATUS.

Ralko, Joe. (2004). *Building Our Future: A People's Architectural History of Saskatchewan*. Calgary: Red Deer Press.

University of Saskatchewan. *Then and Now: Welcome to the University of Saskatchewan College Building*. Brochure.

University of Saskatchewan Archives. (Retrieved 2011). *Agricultural College / College Building / Administration Building*. Retrieved from <http://scaa.sk.ca/gallery/uofbuildings/>



Figure 42. The 'Convocation Moose' in its original place. Photo A-3840, retrieved from <http://library.usask.ca/archives/campus-history/wallpapers.php>



Figure 43. Seating in Convocation Hall.



Figure 44. Portrait of Sir Frederick Haultain.

5. Summary of Character - Defining Elements

Materials

- greystone walls
- granite base
- sandstone detailing & trim
- slate floor and roof tiles, treads and landings
- copper roof flashings
- bronze and brass hardware
- steel window frames and balustrades
- cast iron radiators and balustrades
- glazed terra cotta walls
- terracotta floor tiles
- quarter sawn oak surrounds, doors, window frames

Form

- narrow floor plan
- low massing

Style

- Collegiate Gothic
- oriel and bay windows
- stone vault at main entry
- arched doors, entries, transoms and windows
- crenellation, quoins, string courses, corbels
- statuary niches
- balustrade
- stone relief sculptures
- grotesques and gargoyles

Location

- termination of main axis of The Bowl

Spatial Configuration

- double loaded corridors
- height and skylights in Convocation Hall
- wide corridors



Systems

- steel-framed windows
- fire hose carriers

Uses

- education
- administrative
- faculty club
- library
- convocation hall
(ceremonies, meetings,
concerts, lectures)
- museum
- art collection

Cultural & Chronological Associations

- cornerstone laid by Sir
Wilfrid Laurier
- President's Office
- 'honour roll'
- flu epidemic engraving
- Annie Maude (Nan) McKay
- President Peter MacKinnon



060 & 062

Law & Commerce Complex

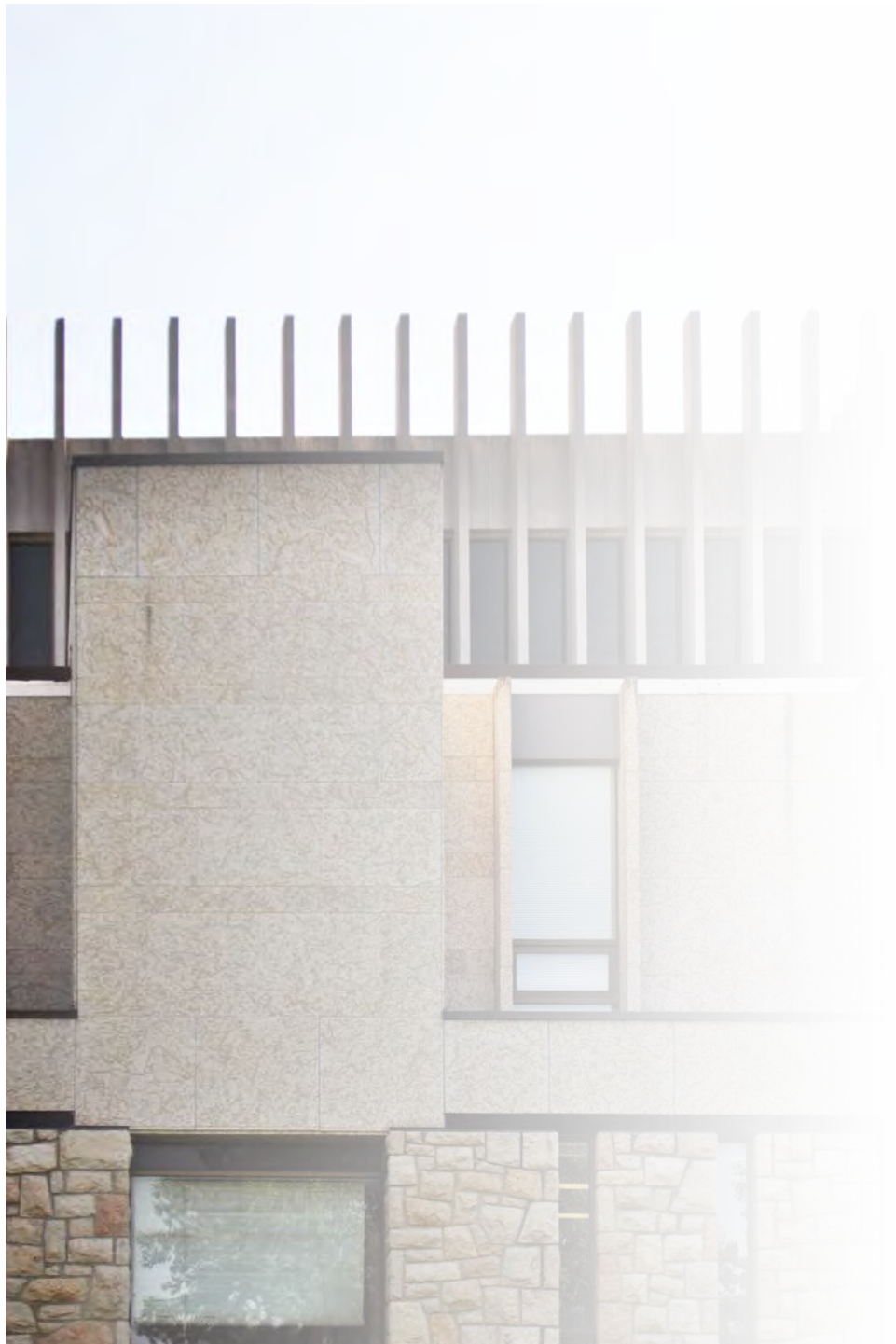

060 & 062

Law & Commerce Complex

Alternate Names

Law and Commerce Building

Law Building and Edwards School of Business

Architect(s)

**John Holliday-Scott, John Holliday-Scott & Associates,
Saskatoon**

Builders

Poole Construction

Construction Dates

1964-1967

Recognition

Law Building: University of Saskatchewan 'A' Listed

Commerce Building: N/A

1. Statement of Significance

The Law and Commerce Buildings were designed and constructed as part of a single project between 1965 and 1967. Their architect was John Holliday-Scott of the Saskatoon firm Holliday-Scott & Associates. Holliday-Scott was one of the most accomplished architects of his generation working in Saskatchewan, and the Law Building, in particular, is one of his best works. In this and other projects such as the [Dentistry Building](#) and the [Lutheran Seminary](#), Holliday-Scott took the traditional architecture of the University of Saskatchewan and translated it into a contemporary architectural language of his own invention. The Law Building has heritage significance as perhaps the best example of the work of this exceptional architect, and as one of the best examples of Modern architecture at the University of Saskatchewan.



Figure 1. North face of the Law Building, 1970 (Photograph CP-5925-A-1 by Creative Professional Photographers courtesy Saskatoon Public Library - Local History Room.)

Both the Law and the Commerce wings of the building have received recent additions. An addition to the north side of the original Commerce Building was designed by Kindrachuk Agrey Architects and completed in 2002. An addition to the south of the Law Building was designed by Stantec Architecture and was completed in 2007. These additions are beyond the scope of this report.

Note: the Commerce Building was renamed the ‘Edwards School of Business’ in 2007. For clarity, it is referred to as the ‘Commerce Building’ throughout this report. The Law and Commerce Buildings are configured with floors numbered basement, ground floor, first floor, second floor. This report follows the same convention.



Figure 2. Greystone.

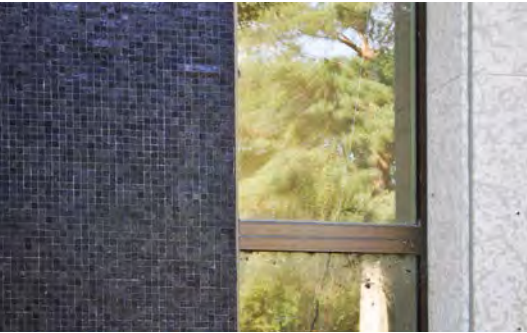

Figure 3. Dark purple ceramic tile, aluminum framed glazing, Tyndall stone.

2. Character - Defining Elements

2.1 Materials

The exterior of the Law and Commerce complex combines materials traditional to the University of Saskatchewan with Modern materials. The dominant exterior materials are 'greystone' and Tyndall stone, traditional materials that characterize much of the architecture of the University of Saskatchewan campus (Figures 2 & 3).^{*} However, while greystone was used on earlier buildings as the principal material for walls, and cut Tyndall stone was used for trim and decoration, here the use of these materials is less constrained. Smooth cut Tyndall stone forms the primary exterior cladding of the Commerce Building, accented by dark purple glazed ceramic tile and grey porcelain enameled panels (Figure 3). On the Law Building, materials are used to differentiate the compositional elements of the building (Figure 4). Rough-faced, uncoursed greystone is used to create a low planter wall that encircles the building. The stone is laid such that the mortar is set back from the surface, to resemble a mortarless 'dry-stone' wall. Rough-faced, randomly coursed greystone is used to define a base on the ground and first floors. Cut Tyndall stone is used to create a middle section on the second floor. Slender precast concrete elements are used to define a roof-top cupola. The proportion of glazing to stone increases at each level: narrow slot windows on the ground & first floors, larger openings on the second floor, and full glazing interrupted only by narrow concrete spires on the cupola. Full aluminum-framed curtainwall glazing is also used to create transparent links between the Law Building, the Commerce classroom wing and the Commerce faculty wing (Figure 5). Greystone, Tyndall stone, precast concrete, ceramic tile and aluminum-framed glazing are all character-defining materials.

Exterior materials are often extended to the interior: at the glazed link joining the Law and Commerce buildings, Tyndall stone and greystone are both extended from the exterior to the interior, separated only by a sheet of glass (Figure 6). The glazed entrance lobby and the link between Commerce and the [Arts Complex](#) are also differentiated from other areas of the building by the use of Welsh quarry tile as a flooring material. The tile flooring of the links and the interior application of exterior materials are character-defining elements.

^{*}For further information on building stones used at the U of S, refer to ['Appendix: Stone'](#)

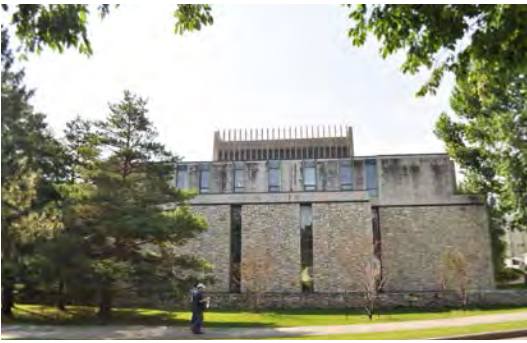

Figure 4. North facade.



Figure 5. Glazing.



Figure 6. Tyndall stone on the exterior and interior separated by glazing.



Figure 7. Terrazzo and Welsh quarry tile.

Staircases throughout both buildings have terrazzo treads and landings with steel balustrades (Figures 7 & 8). Exit stairs have wooden handrails. The central stair in the entrance lobby is a beautiful feature of the building. It is designed such that its steel handrails form its structure, and its stainless steel and terrazzo treads are suspended by tension rods that form its balusters. In this way the whole element is made lighter, such that it appears to float in the light-filled space of the glazed lobby. The stair in the entrance lobby is a character-defining element.



Figure 8. Steel and terrazzo staircase.

Aluminum, marble wall tile and dark stained oak are found throughout the interior of the Law Building. Oak paneling with aluminum trim is used in the 'Moot Court' room. An oak jury box, witness stand, judges' bench and rolling chalkboard and frame are also found in this room (Figure 9). (See Section 3 Associated Objects). Oak is also used extensively in the Law Library in the shelving, study carrels, tables and other millwork. Oak is also generally used for doors and transoms, and wall paneling. Columns in the Law Building are faced with natural anodized aluminum and brown marble tile, and have oak baseboards (Figure 12). Other columns were clad in white vinyl. The balustrade on the second floor corridor overlooking the library is a low wall made of striated, painted concrete. This balustrade, shown in Figure 13, is topped with a steel and oak hand rail. Painted concrete, dark stained oak, marble and aluminum are character-defining materials of the Law Building.

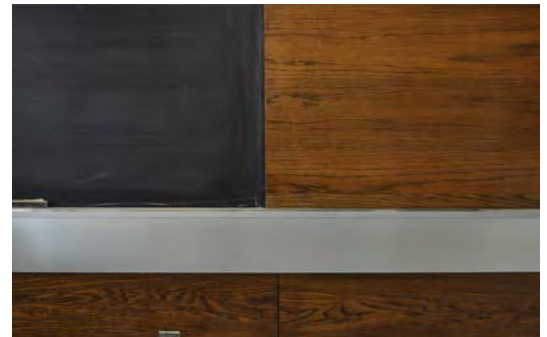

Figure 9. Oak chalkboard cover, oak wall panel with aluminum trim.

The interior materials of the Commerce Building are generally less opulent. The corridors are faced in painted concrete block.

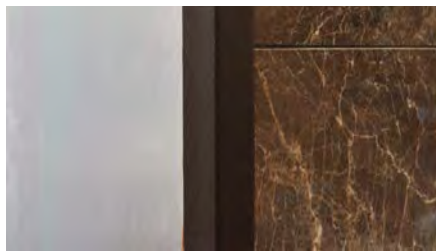

Figure 12. L to R: natural anodized aluminum and brown marble.

Structural columns in the Commerce Wing are painted concrete. Wooden elements such as doors and transoms are differentiated by the use of birch rather than oak. However, in select locations, such as the walls on each floor separating the Commerce Building from the [Arts Building](#), marble tile is used as a finish material. Holliday-Scott often used accent colours in his architecture. In the case of the Law and Commerce Complex the architect specified custom made carpets that have since been removed. Red carpet was used in the Commerce Building and blue in the Law Building.



Figure 10. Oak strip panelling.



Figure 13. Striated painted concrete wall, steel and oak guard rail.

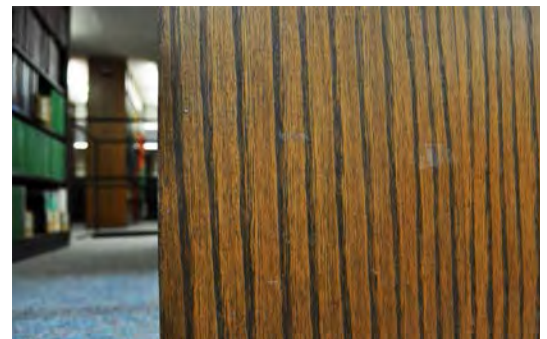

Figure 11. Oak shelves.



Figure 14. The form of the Law and Commerce Complex, July 1968. Photo A-9702, retrieved from http://scaa.usask.ca/gallery/uofs_buildings/

2.2 Form & Style

The Law and Commerce complex is an excellent work of late Modern architecture. The Law Building, in particular, is a masterful building in which the principles of Modernism are employed not as rigid precepts, but as parts of a broader framework of possible references, selected and manipulated for their expressive potential. In this way, the traditions of the university and of the legal profession were given a clear and contemporary form.

A material, spatial and stylistic difference is discernible when comparing the Law and Commerce Buildings. In an interview carried out for this report, Holliday-Scott attributed this departure to the philosophical differences between the two schools, and the tendency of commerce to be more practical, compared to law, which places a greater emphasis on ideas. The architect reflected these attributes by giving the exterior of the Commerce Building a more regular form and the Law Building one of greater complexity. The functional program for the Law Building also offered opportunity for more complexity. At the time, Dean of Law Otto Lang described the Law Building as a

structural expression of the majesty of law.

Although it functions as two buildings, the Law and Commerce complex is arranged formally as a series of three functional components, linked and separated by glazed connectors. These three components are the Law Building, the Commerce classroom wing and the Commerce faculty wing. They are each three-storeys in height, in addition to a basement level in the Law Building. The three wings are arranged in a linear fashion, roughly west to east. The Law Building and the Commerce classroom wing are connected by a glazed entrance lobby and central stair. The two parts of the Commerce Building were originally connected by a glazed link containing a student lounge on each of its three floors, but this part of the building was substantially altered by the 2002 addition. The Commerce Building defers in some respects to the design of the classroom wing of the Arts complex, to which it is adjoined, matching its datum lines and principle materials.

Modernist architecture in its early and most orthodox period was characterized by a simplification of forms, by a rejection of applied ornament and by an emphasis on the expression of function and structure. By the late period of Modernism, in the 1960's, this orthodoxy had begun to yield to a more expressive impulse in the work of architects such as Eero Saarinen, Alvar Aalto and Oscar Niemeyer. Also by the late 1960's and 1970's, architects and theorists such as Louis Kahn and Robert Venturi were beginning to reintroduce the potential of historical architectural forms and references. Venturi's influential manifesto, *Complexity and Contradiction in Architecture*, was published in 1966. By this point, the Law-Commerce complex was already well under construction, but here and in his other work at the University of Saskatchewan, John Holliday-Scott anticipated the re-introduction of history advocated by Venturi. The results are arguably more subtle and successful than most of the work of the later Post-Modern period, when this approach reached its zenith.



Figure 15. Precast concrete spires.



Figure 16. Rusticated greystone base.

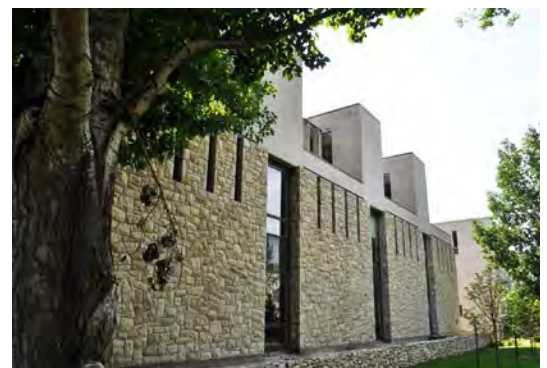

Figure 17. Rooftop projections.



Figure 18. Windows resembling battlements.

In his combination of traditional and Modern materials and in his inventive reinterpretation of traditional forms, Holliday-Scott gave a delightful contemporary expression to the traditions of the College of Law and the university. Holliday-Scott tapped into a broad stream of cultural references, not restricting himself to the particular language of Collegiate Gothic precedent favoured by his predecessors at the University of Saskatchewan, or by the prevailing styles of his own time. The tripartite arrangement of the Law Building, with a heavy rusticated base, a more refined midsection and a lighter filigreed cap was a device borrowed from the Classical architecture of the Renaissance. On the west side of the Law Building, the heavy stone walls at the base of the building are composed with a series of narrow windows to resemble the battlements of a mediaeval castle (Figures 17 & 18). The cupola, with its slender screen of spires, recalls the [Chemistry \(Thorvaldson\) Building](#) of Brown & Vallance and its own earlier precedents (Figure 19). Although clear in their inference, all of these forms are rendered in a modern way.

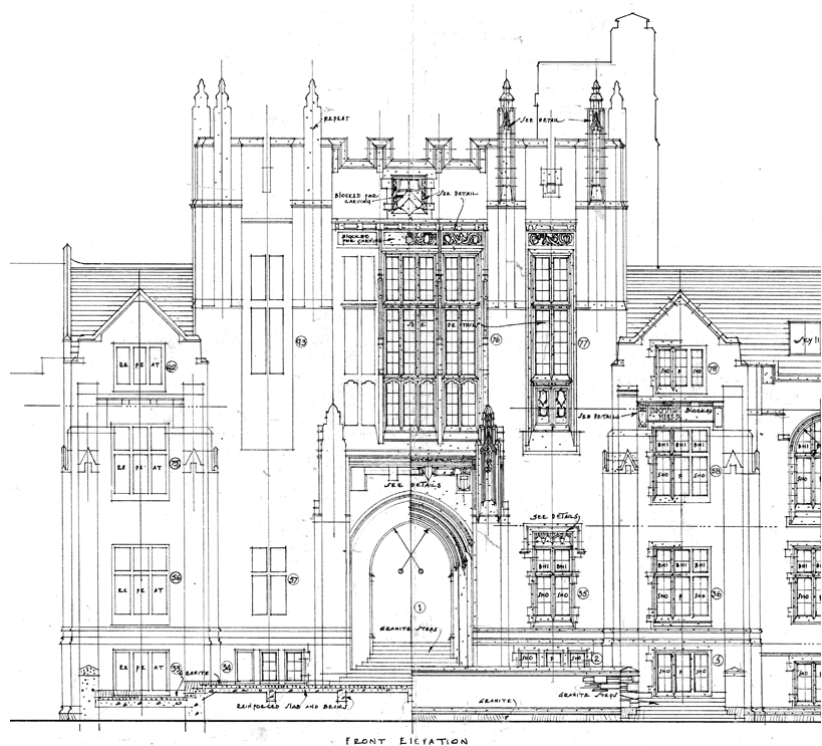

Figure 19. Front elevation of the Thorvaldson Building. Retrieved from Facilities Management Division Asset Record System, File TB-14-T.



Figure 20. Continuity of material surface: oak door and narrow oak frame in an oak clad wall.

Other aspects of the building are unequivocally modern. The use of glazing to define connective spaces separating discreet functions is a common device of Modernist architecture, and similar to the approach taken in the [Arts complex](#). Holliday-Scott's expression of materials is also typically modern. Often material

surfaces are used to define a form or volume, such as the faculty lounge and reading rooms on the second floor, which are rendered as discrete oak boxes projecting into the space of the library. This expression is supported by beautiful detailing; the oak doors leading into these rooms are built with narrow oak frames such that their material surface is uninterrupted (Figure 20).

The use of exposed structural elements is another hallmark of Modernist architecture employed to full expressive effect in the Law and Commerce Buildings. The concrete waffle slabs forming the floor structures of the building are exposed as finished ceilings in the entrance lobby and in the library (Figures 21 & 22). In the lobby, also, steel columns are left exposed. The stair in the entrance lobby, with its open treads suspended from above by steel tension rods, recalls a classic Modernist precedent: Eero Saarinen's suspended stair in the General Motors Technical Center in Detroit (1949-55) (Figure 23). The complex spatial configuration of the Law Building, with the library as its central focus, evokes the interconnected spaces of Paul Rudolph's Yale School of Architecture (1959-63) (Figure 25 & 26).



Figure 21. Library cupola.

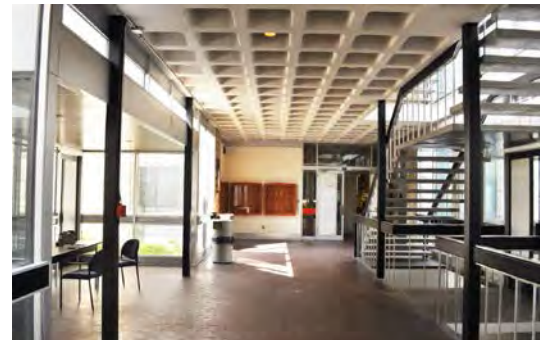

Figure 22. Exposed steel columns and concrete waffle slab.



Figure 24. Stair in lobby.



Figure 23. Stair in General Motors Technical Center, Detroit. Retrieved from <http://www.autofieldguide.com/cdn/cms/GMTechnical-Center.jpg>



Figure 25. A perspectival section through the Yale School of Architecture by Paul Rudolph. Retrieved from <http://places.designobserver.com/feature/reading-rudolph/12607/>

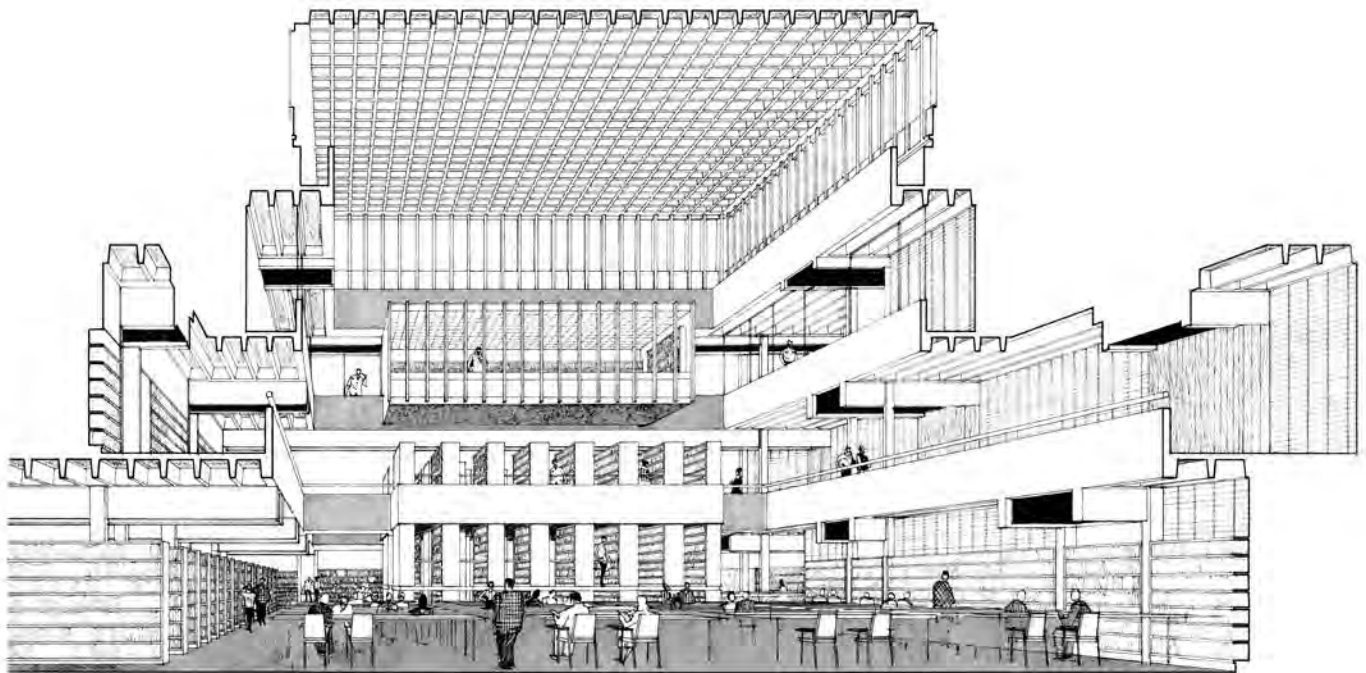

Figure 26. A perspectival section through the Law Library. Retrieved from Facilities Management Division Asset Record System, File LC-49-P.

2.4 Location

The Law and Commerce Buildings are located on the main campus of the University of Saskatchewan. They are oriented roughly east-west, with their main entrance facing north towards Campus Drive, and are connected to the [Arts Complex](#) to the south. The angle of their orientation derives from that of the Arts Complex, and the [Thorvaldson Building](#). The location of the original portions of the complex is indicated in green on the contemporary campus plan shown in Figure 27.

2.5 Spatial Configuration

The Law and Commerce complex is arranged in plan as a series of three components: the Law Building, the Commerce classroom wing and the Commerce faculty wing (Figure 27).

The Law Building is roughly square in plan, and three stories in height, in addition to its basement. It is planned with the three-storey volume of the Law Library in the middle of the ground floor (Figure 28). This forms a central core, around which all of the other program elements – book stacks, classrooms, seminar rooms and offices are arranged. Holliday-Scott looked to the Parliamentary Library in Ottawa as a precedent for the interior of the Law Library, not for its shape or detail, but for the feeling that the space elicits (Figure 29). Holliday-Scott felt that in the case of the Law Building it was inappropriate to conceal the stacks as in some libraries. The Parliamentary Library served as an example of a, “building in the round...that has a mass that builds to the center,” (Holliday Scott, personal communication, September 5, 2013). The arrangement of stacks around a central space is clearly legible in the design of both the Parliamentary Library and the Law Library.

The device of using a large central space as the heart of a building was a hallmark of the work of John Holliday-Scott. In his own words, Holliday-Scott “...always liked doing buildings that work from the middle out...” (Holliday-Scott, J. Personal Communication, September 5, 2013). Otto Lang, the Dean of Law during the design and construction of the Law Building, described the library as, “the centre and heart of the structure around which everything else is built.” Holliday-Scott later designed a similar space in the [Dental Clinic](#) building, also on the University of Saskatchewan campus.

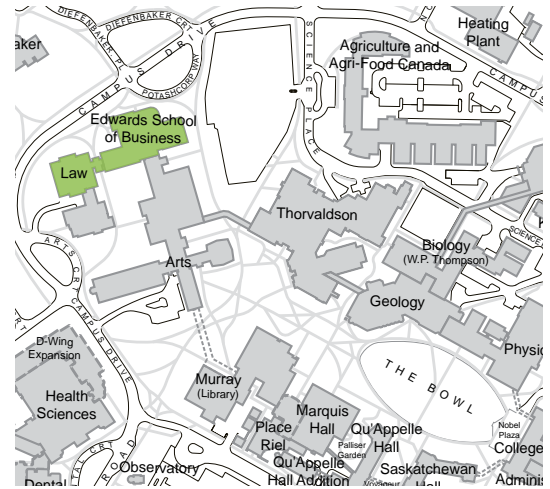

Figure 27. The location of the Law and Commerce Buildings.



Figure 28. Law library.



Figure 29. The Parliamentary Library in Ottawa. Photo retrieved from <http://www.freeactivities.ca/free-reading-time-at-the-ottawa-public-library/>

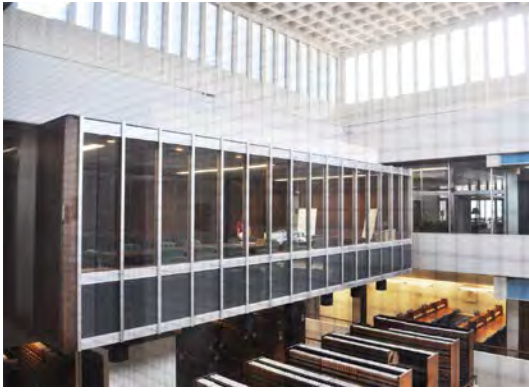

Figure 30. Projecting volume in the law library.



Figure 31. Library staircase.

The Law Library is arranged over two floors, including all of the ground floor and parts of the first floor. Provisions for additional book storage space were made in a basement level, initially left unfinished but completed in 1980. The reading room is at the centre of the ground floor library space, ringed by book stacks and library support functions arranged around the perimeter. It is a soaring light-filled space, stretching more than three storeys in height and crowned by a cupola with clerestory glazing (Figures 26 & 28). On the first and second floors, corridors encircle the space and overlook the reading room. A smaller faculty reading room and a faculty lounge project out into the space on the second floor (Figure 30). Contained within the volume of the reading room, a separate structure of book stacks spans between the basement and first floors and is connected back to the first floor by two short bridges. In this structure, four floors of bookshelves are compressed into the vertical dimension of the three adjacent floors, and the structure has its own internal stair (Figure 31). The Law Library, in its materials and spatial form is a character-defining element.

The Commerce faculty wing is somewhat smaller than the Law Building, but is similarly square in plan. On each of its three floors, a large circular room is located in the centre of the plan, containing a faculty lounge on the second floor and seminar rooms on the ground and first floors (Figures 32 & 33). The central portion of the second floor is illuminated by clerestory glazing in a large square cupola (Figure 35). On all three floors, smaller offices and seminar rooms are arrayed around the perimeter.

The Commerce classroom wing is a three-storey linear form, connecting the Law Building and Commerce faculty wing. On each floor, a series of classrooms is arranged on the north side of a double-loaded corridor. Graduate student offices, washrooms and other support functions are arranged on the south side. A large reading room was also provided on the north side of the second floor, featuring a high ceiling, lined with wood and illuminated by a row of skylights. The reading room is a character-defining element (Figure 36).

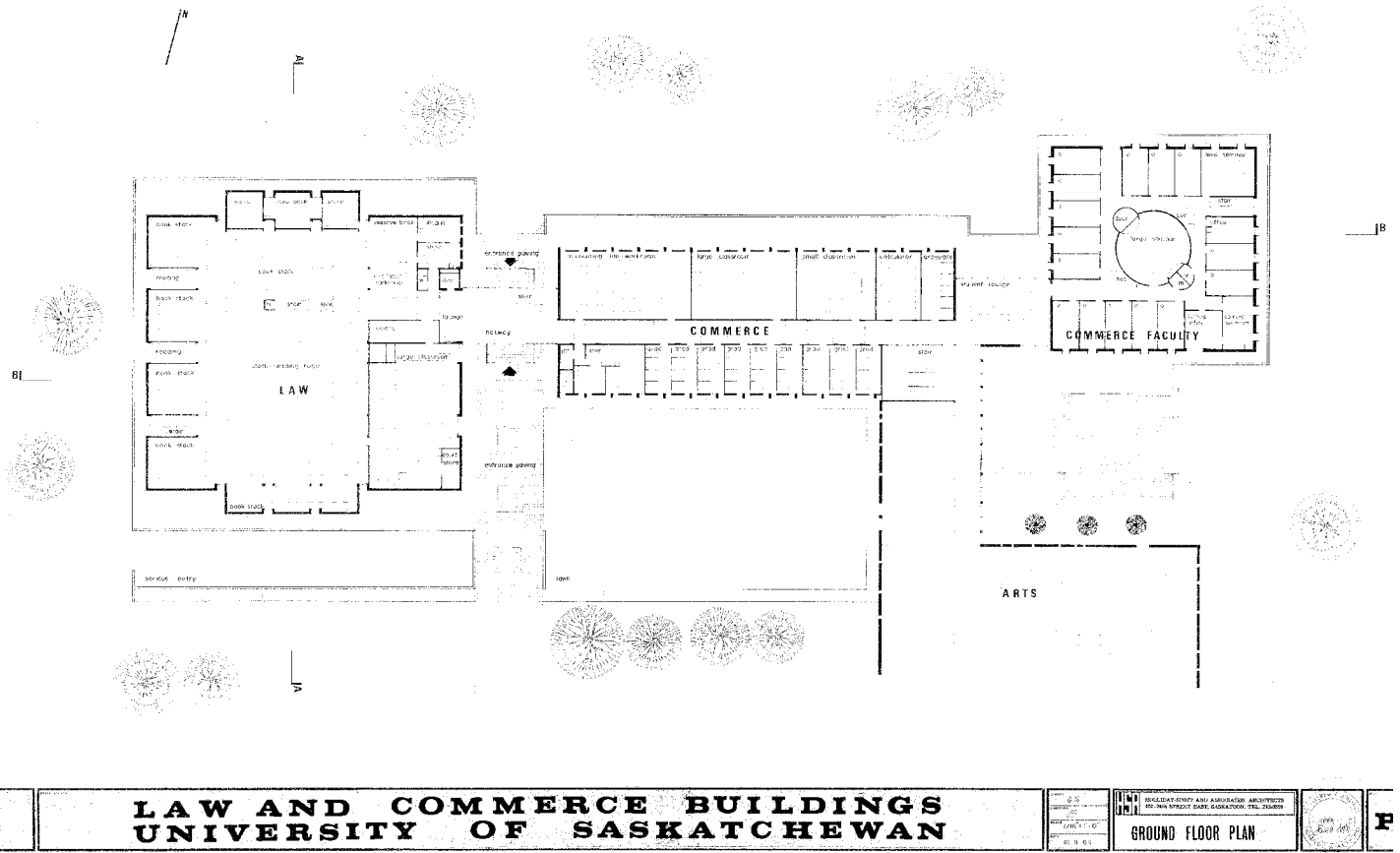

Figure 32. The original ground floor plan of the Law & Commerce Complex. Retrieved from Facilities Management Division Asset Record System, File LC-55-P.

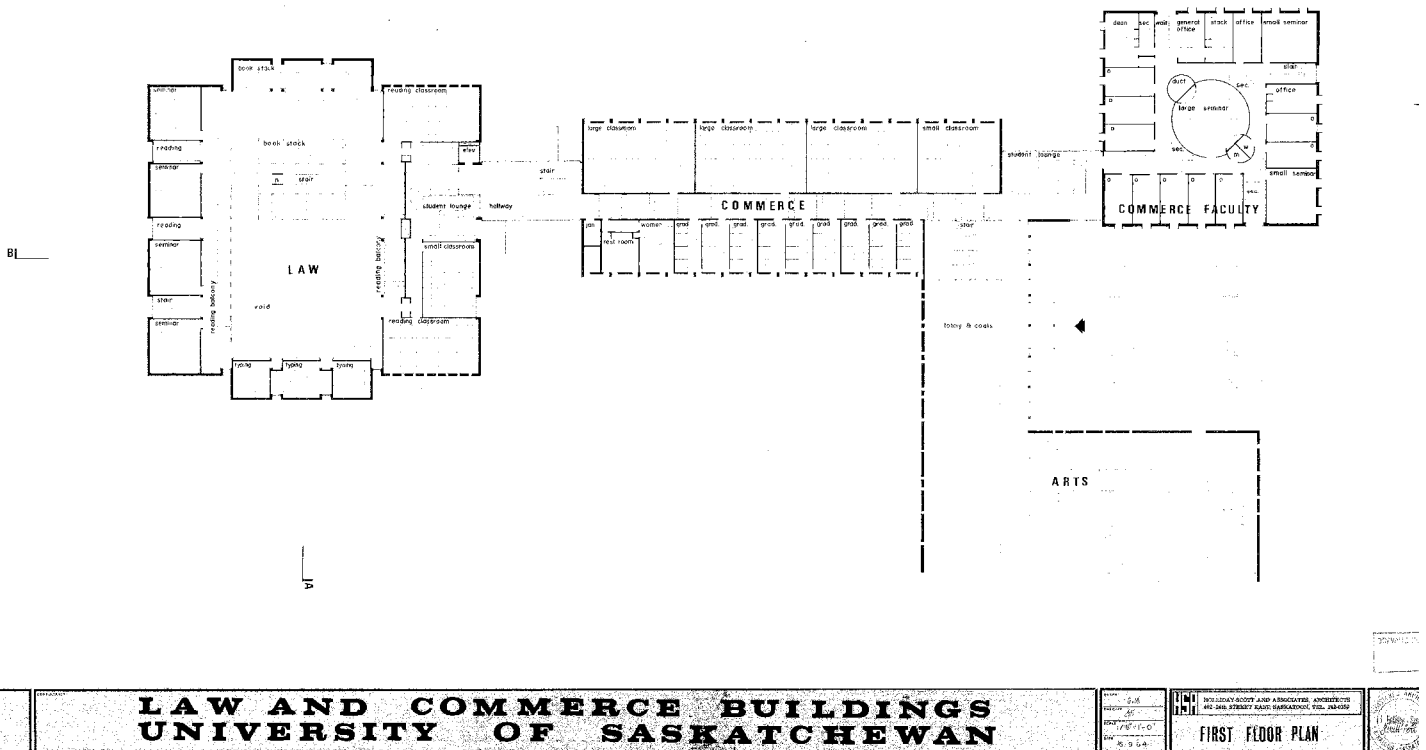

Figure 33. The original first floor plan of the Law & Commerce Complex. Retrieved from Facilities Management Division Asset Record System, File LC-199-C.

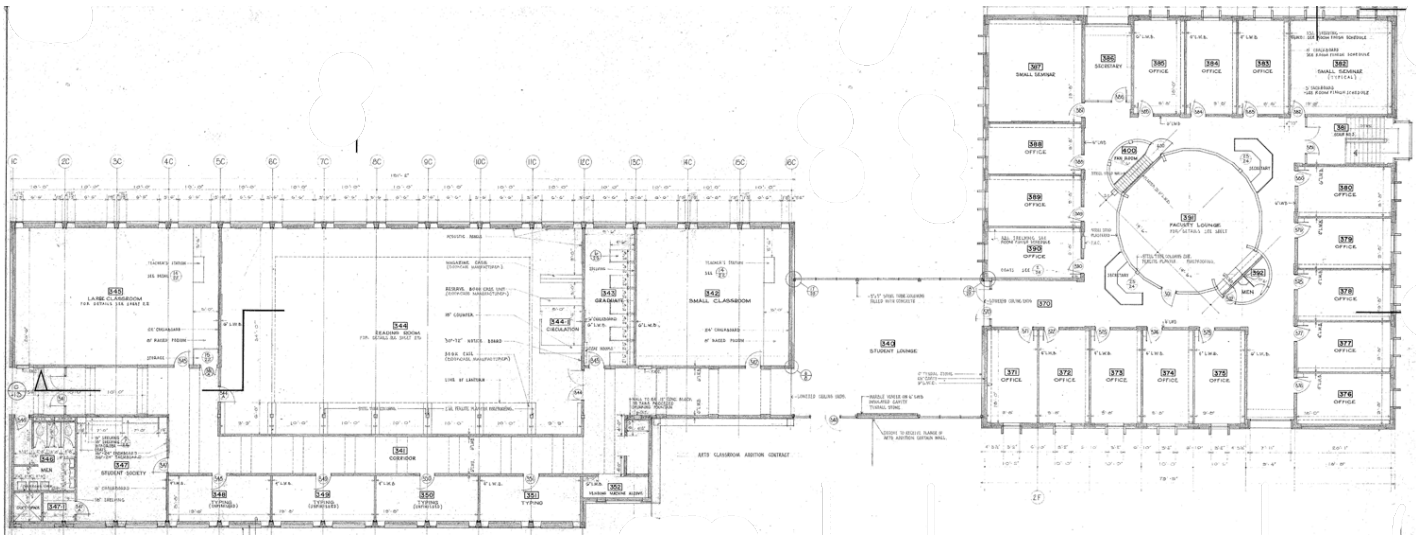

Figure 34. The original second floor plan of the Edwards School of Business. Retrieved from Facilities Management Division Asset Record System, File LC-199-C.

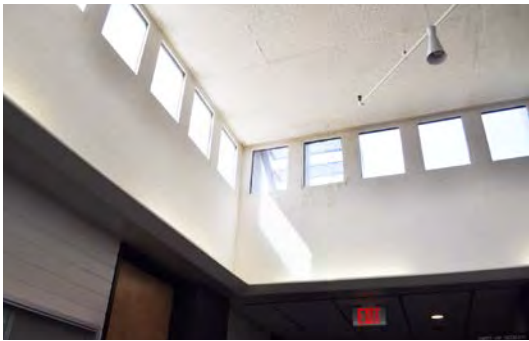

Figure 35. Clerestory glazing in the Edwards School of Business.

2.6 Systems

The Law and Commerce Buildings were constructed with a cast-in-place concrete structural frame and concrete floor slabs. Both buildings feature a ‘waffle’ slab floor system – a long span concrete slab system notable for the distinctive coffered pattern of its bottom surface, resembling a waffle. In many areas, such as the ceiling of the Law library and in the entrance lobby, the underside of the waffle slab is exposed for expressive effect. Exposed structural steel columns are also used in some instances, such as the entrance lobby and the reading room on the third floor of the Commerce classroom wing. The expression of structural elements such as concrete columns and waffle slabs is a character-defining element.



Figure 36. The Commerce Reading Room.

2.7 Use(s)

The Law and Commerce Buildings were built for the purposes of education in law and business administration, and still fulfill these functions. The construction of the two recent additions has shifted the distribution of uses in both buildings, particularly due to an increase in instructional space. However, the original uses and their accommodations remain essentially intact. The use of these buildings for education in law and commerce is a character-defining element.

2.8 Cultural & Chronological Associations

The Law and Commerce buildings are associated with the history of the College of Law and the Edwards School of Business. The establishment of both a College of Law and of a Department of Commerce within the College of Arts & Science were early ambitions of Walter Murray, the first President of the university (Hayden, 1983 p. 126). The University of Saskatchewan appointed its first law professors, Arthur Moxon and Ira MacKay, in 1913. Later that year, the first classes were launched in a Bachelor of Laws program. In its early days, classes in the new College of Law were conducted from office buildings, in order to accommodate the schedules of those students articling in law firms downtown. Before the construction of its permanent home in the Law Building, the College of Law was housed in the [MacKinnon Building](#), then [Qu'Appelle Hall](#), and finally in the [Murray Building](#). The Edwards School of Business was established in 1914 as the School of Accounting, and began admitting students to a Bachelor of Science program in Accounting in 1917. This was the first university-level program in accounting offered in Canada. In 1936, the school was named the College of Accounting, and became the College of Commerce in 1943. In 2007, the school was re-named after Canadian entrepreneur N. Murray Edwards as the Edwards School of Business.

The College of Law and the Law Building can be associated with Canada's 13th Prime Minister, John G. Diefenbaker (Figure 37). Before becoming Prime Minister, Diefenbaker earned his Law Degree from the University of Saskatchewan. Diefenbaker was the first student at the University of Saskatchewan to receive three degrees, having previously earned both a Bachelor of Arts and a Master of Arts degree. Diefenbaker returned to the university to speak at the Law Building's opening.

The Law-Commerce complex can be associated with its designer, architect John Holliday-Scott of the firm Holliday-Scott & Associates Architects. Holliday Scott was born in the UK, and immigrated to Canada in 1957 after receiving his architectural degree from Kingston College of Art. He worked for a time with the firm Chamberlin, Powell and Bon and grew to respect their ability to incorporate architecture into context without being imitative. In Canada, Holliday-Scott first worked with the Saskatoon Firm Kerr and Cullingworth for two years before starting his own firm. Holliday-Scott's first building for the University of Saskatchewan was the dining hall at Emma Lake, Kenderdine Campus. He was also the architect for the [Dental Clinic](#) and the [Lutheran Seminary](#).

The Law Building can be associated with the Native Law Centre, which was founded in 1975 by Dr. Roger C. Carter. The Centre was created to facilitate access to legal education for Aboriginal peoples, to promote the interests of Aboriginal peoples within the legal system, and to disseminate information concerning Aboriginal



Figure 37. Portrait of John G. Diefenbaker.



Figure 38. Portrait of Sir Frederick Haultain.



Figure 39. Portrait of Arthur Moxon by Augustus Kenderdine.



Figure 40. Fender inscribed with will and pocket knife used to inscribe will.

peoples and the law. The Centre became a department of the College of Law in 1984 and was established in purpose-built space as part of an addition to the Law Building completed in 2007.

3. Associated Objects

Around the Law Library are a series of paintings of notable graduates and former faculty of the College of Law. These include paintings of John G. Diefenbaker, Sir Frederick Haultain (First Premier of the North-West territories) and a portrait of Arthur Moxon by Augustus Kenderdine. (Figures 37 through 39).

In addition, photos of graduating Law and Commerce classes are distributed throughout the building. The 1919 graduating class photo features a young John G. Diefenbaker. The paintings and the graduate photos are associated objects of heritage value.

A bust of Emmett Hall, alumnus, chancellor and justice of the Supreme Court of Canada is located in the Law Library. Hall was present at the laying of the cornerstone of the MacKinnon building by Sir Wilfrid Laurier and would later attend Law School at the University of Saskatchewan alongside John G. Diefenbaker. Hall later became known as a father of medicare alongside former premier T.C. Douglas. One of Hall's major contributions, as chair of a royal commission, was to propose a publicly financed national health plan that included a wide range of health services in addition to medical and hospital care.

The Law Library holds the holographic will of Cecil George Harris. The holographic or hand written will was etched on a tractor fender by Harris who became trapped under the equipment outside of Rosetown on June 8, 1948. The etching, done by pocket knife, reads, "In case I die in this mess, I leave all to the wife. Cecil Geo Harris." After Harris died from his injuries it was determined by the courts to be a valid holographic will. The fender on which the will is inscribed, and Harris' pocket knife were donated to the College of Law for public display in 1996 by the Kerrobert Courthouse (Figure 40).

Holliday-Scott designed a jury box and witness stand to accompany the Moot Court classroom. These furnishings and their materials are original to the building (Figure 42).

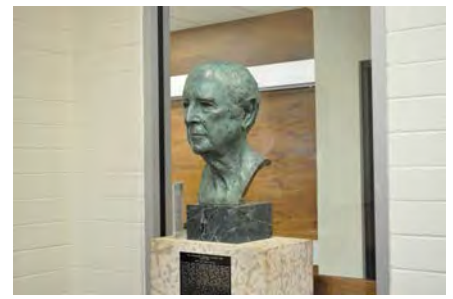

Figure 41. Bust of Emmett Hall.



Figure 42. Oak and aluminum jury box and oak witness stand.

4. Supporting Documents

Author Unknown. (1967, November-December). Colleges in Construction: Law Building Officially Opened. *Canadian University*, 48-49.

Author Unknown. (January 23, 2009). The Last Will and Testament of Cecil George Harris. *On Campus News*, . Retrieved from http://news.usask.ca/archived_ocn/09-jan-23/see_what_we_found.php

Facilities Management Division (2011). Asset Resource Database [Data File]. Retrieved from \\usask\fmddfs\files\iis\IIS_Public\ARS

Gruending, D. (Retrieved 2013). *The Encyclopedia of Saskatchewan, Hall, Emmett 1898-1996*. Retrieved from http://esask.uregina.ca/entry/hall_emmett_1898-1996.html

Holliday-Scott, J. Personal Communication. September 5, 2013

Hayden, M. (1983). *Seeking a Balance: University of Saskatchewan, 1907-1982*. Vancouver: University of British Columbia Press.

Kerr, D. (2011, Summer). John Holliday-Scott Designed U of S Law Building and Wascana Place. *Worth: Saskatchewan's Architectural Heritage Magazine*, 28 (2), 18-19.

University of Saskatchewan Archives. (Retrieved 2011). *Campus Buildings: Law-Commerce Complex*. Retrieved from http://scaa.sk.ca/gallery/uofs_buildings/

University of Saskatchewan Archives. College of Law, RG 2082, 006 College of Law Building, 1961-1967.

Wolfson, D. (Wolfsun Productions). (2009). *Edifice & Us* [Season 2 Episode 1]. Buildings with a Heart: John Holliday-Scott's Buildings. Retrieved from <http://www.youtube.com/watch?v=14PAbvxCi4o>



5. Summary of Character - Defining Elements

Materials

- greystone and Tyndall stone wall cladding
- aluminum-framed glazing
- wood: oak & birch
- welsh quarry tile flooring
- steel structures and staircases
- terrazzo flooring
- marble wall tile
- painted and plastic sprayed concrete walls & ceilings
- aluminum trim
- glazed ceramic wall tile

Form & Style

- irregular massing
- three distinct components: Law Building, Commerce classroom wing, Commerce faculty wing
- slot windows
- references to battlements
- precast concrete spires
- glazed connectors & entry
- exposed structural elements: waffle slabs, exposed columns
- material continuity
- rusticated greystone wall
- tripartite form of law building
- stair in entrance lobby

Location Building

- orientation in relation to Arts
- facing Campus Drive & river

Spatial Configuration

- Law Library
- double loaded corridor in Commerce classroom wing
- glazed connectors & entry

Systems

- concrete structure with waffle floor slabs

Uses

- education in law and business
- library
- moot court
- reading room

Cultural & Chronological Associations

- history of College of Law and Edwards School of Business
- John G. Diefenbaker
- Architect John Holliday-Scott



061

Arts Complex

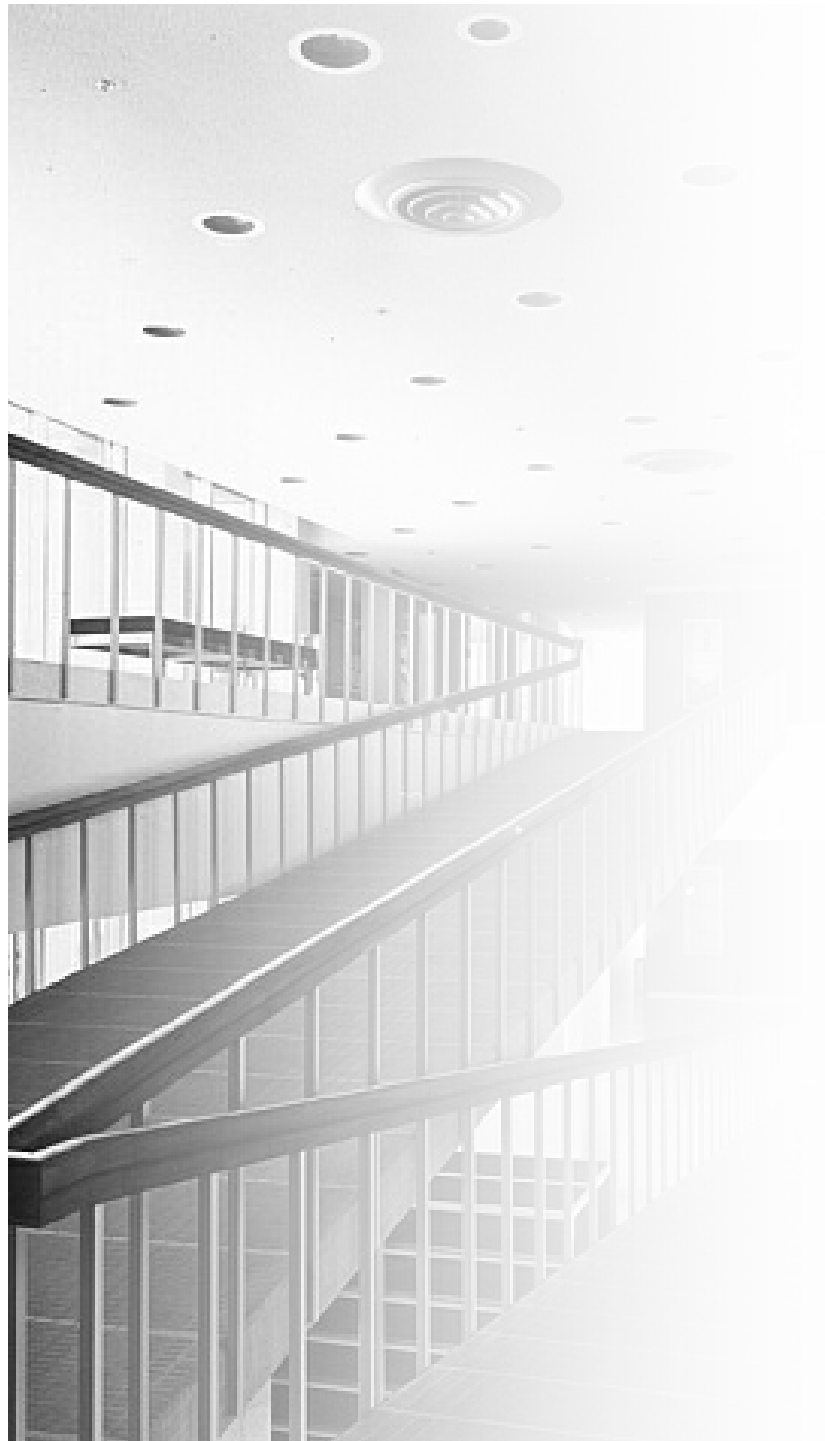

061

Arts Complex

Alternate Names

Arts Building

Arts Tower

Architect(s)

Shore and Moffat Architects, Toronto

Builders

W.C. Wells Construction

Bird Construction

Construction Dates

1958-1967

Recognition

N/A

1. Statement of Significance

Aspirations for an arts building began with the first president of the university, Walter Murray, who considered a building for the liberal arts integral to the idea of a university. In 1930, architectural plans for Haultain Hall were put out for tender. Haultain Hall was an ornate building in the Collegiate Gothic style, intended to be located west of the [Chemistry \(Thorvaldson\) Building](#). The depression of the 1930's intervened and plans for the building were first postponed, then cancelled due to economic duress.

It was not until Canada Council funding became available specifically targeting education in the liberal arts that the Arts Complex was realized, in stages, between 1958 and 1967. Its buildings were designed in the Modern style by Shore and Moffat Architects of Toronto, and are representative of the architecture of the period. Together, its tower, two classroom wings and lecture theatre pavilion comprise 7700 square metres. The Arts Complex included the first college buildings not to be constructed directly on ['The Bowl'](#), but the tower was also the first building on campus to rise above four storeys and was intended as a focal point and a symbol of the central place of the arts at the university.



Figure 1. Theatre wing, with Tyndall stone panels, blue porcelain enameled spandrels and grey column covers.



Figure 2. Tyndall stone, grey porcelain enameled panels.



Figure 3. Architect's sketch of the Arts Building. The Arts Tower is depicted at its original height of seven storeys, before the addition of the final four floors. Photo A-112, retrieved from http://scaa.sk.ca/gallery/uofs_buildings/

The Arts Complex was intentionally sited to terminate the axis of [The Bowl](#), and to interrupt the 1909 master plan. Its siting reflects a critical shift in the planning principles that had occurred in the years prior to its construction, and the abandonment of the 1909 Campus Plan. The Arts Complex has some heritage value in that it is typical of the architecture of the late Modern period and in that it represents the culmination of years of intention. It answered the need for classroom and office space during a period of rapid growth at the university and fulfilled the long-standing ambition of the College of Arts and Science for a home for the arts.

2. Character - Defining Elements

2.1 Materials

The design of the Arts Complex introduced new building materials to the campus and used traditional materials in new ways. Porcelain enameled steel panels are employed extensively on the exterior elevations and in the interiors (Figure 1). Tyndall Stone is the primary cladding material of the tower and theatre pavilion (Figures 1 & 2). Greystone is used as the main cladding material of the two classroom wings, and also at the base of the tower and theatre.* Glazing is an important element in the design of the complex, being used extensively to enclose the connective spaces in the building that link the four principle wings.

*For further information on building stones used at the U of S, refer to [‘Appendix: Stone’](#).

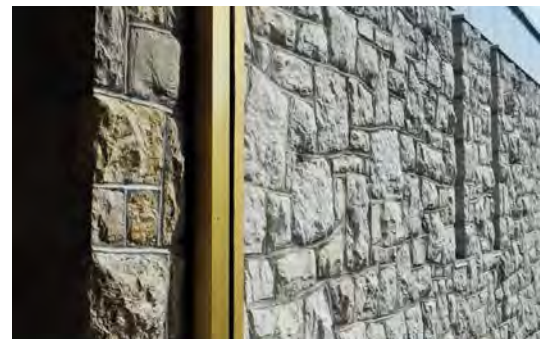

Figure 4. Greystone divided by glazing framed in gold anodized aluminum.

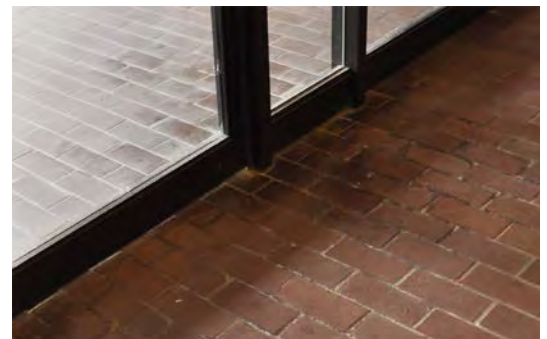

Figure 5. Brick flooring.



Figure 6. Glazed circulation space.



Figure 7. Gold anodized aluminum window frame, with steel hardware.



Figure 8. Terrazzo flooring, painted brick wall with blue porcelain enameled panels.



Figure 9. Buff coloured brick.

Although greystone and Tyndall stone were traditional materials at the university, their use in the Arts Complex was characteristically Modern. Tyndall stone is used on the tower as a panel, alternating with floor-to-ceiling windows, and interrupted at every floor by a horizontal band of grey porcelain enameled panels. This expression of stone as a panel rather than as a continuous wall or series of columns, reveals the fact that it is not a structural element but functions only as a cladding. Similarly on the theatre wing, Tyndall stone panels alternate with openings, suspended without obvious means of support above the ground level (Figure 1). This expression of the function of materials and their characteristics was a principle of the Modern movement in architecture. Repetition was another compositional device employed with typically Modernist rigour on the Arts Tower. Tyndall stone, greystone and porcelain enameled steel panels are character-defining materials of the Arts Complex.

Both greystone and Tyndall stone are also used as an interior material, often expressed as the extension of a wall from the exterior to the interior. This device of extending material surfaces from outside to inside was a way of visually connecting interior and exterior space, and was another distinguishing feature of modern architecture (Figure 4). Figure 5 shows the same principle being applied in the use of brick flooring.

Glazing is used extensively in the building, and its formal and stylistic implications are discussed below in Section 2.2 Form & Style. Glazing is framed in gold anodized aluminum, and is a character-defining element (Figures 6 & 7)

On the interior, terrazzo is used as a flooring material throughout the public spaces of the complex (Figure 8). Brown brick (Figure 5) was used for the flooring in the vestibules. The walls of the classroom wings are faced in a buff colored brick. The brick has been painted in the case of the west wing and has been left in its natural state in the north wing (Figures 8 & 9). Terrazzo and brick flooring, and brick as an interior material, are character-defining elements.

2.2 Form & Style

The Arts Complex is a representative example of late Modern architecture, conforming generally to the principles of the International Style in its forms and spatial arrangements, but making concessions to context in its materiality. Modernist architecture was characterized by a simplification of forms, by a rejection of applied ornament and by the expression of function, structure, and the inherent characteristics of materials. New materials and their properties were emphasized: steel, concrete and glass. Spatial arrangements were simplified and rationalized. By the late period of Modernism, in the 1960's, repetition and patterning based on geometrical forms had come to be used commonly as a compositional and decorative device.

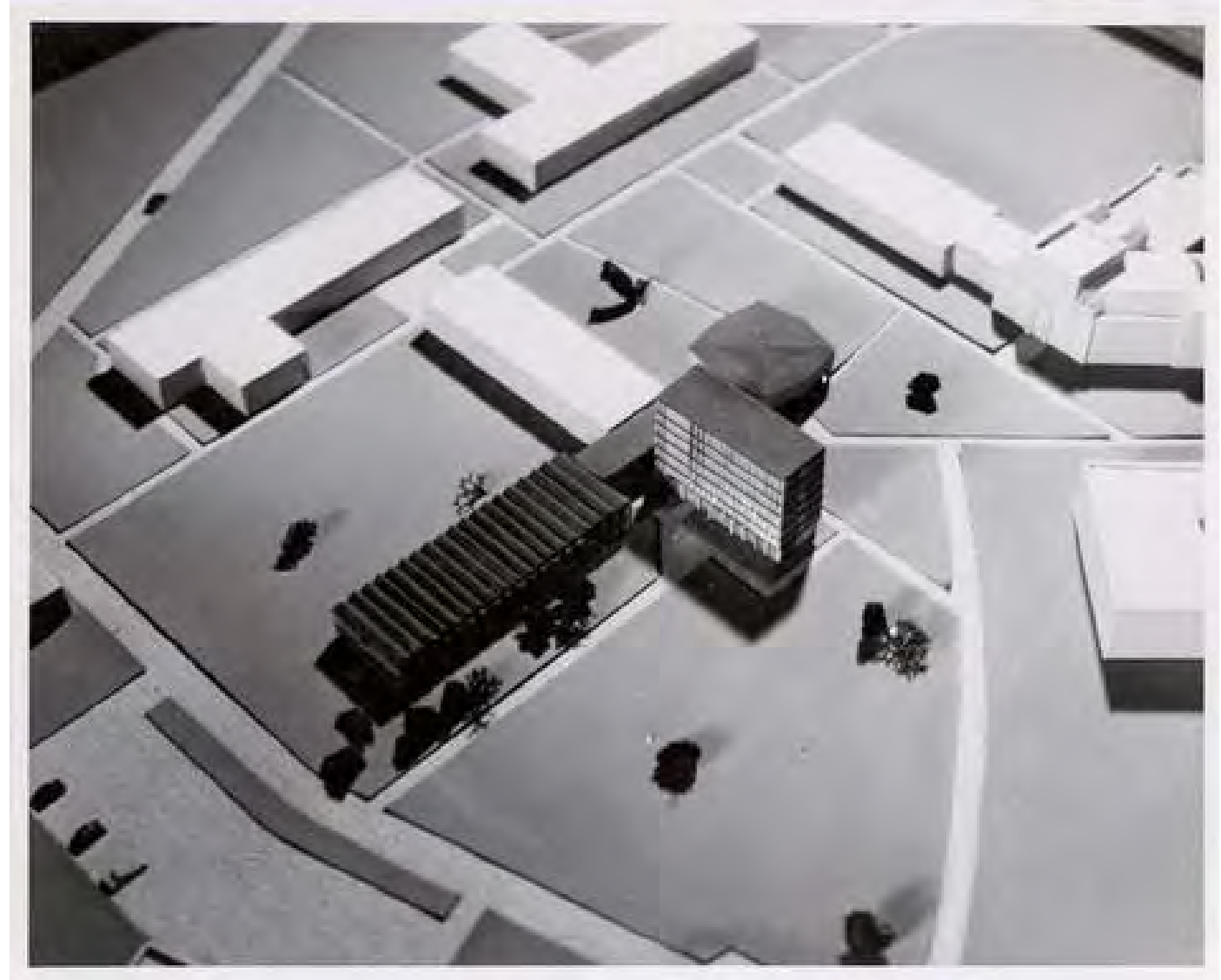

Figure 10. A 1959 architect's model of the Arts Complex. Note that here the tower is portrayed at only seven storeys and the north wing of classrooms is not yet designed. Photo A-110, retrieved from http://scaa.sk.ca/gallery/uofs_buildings/

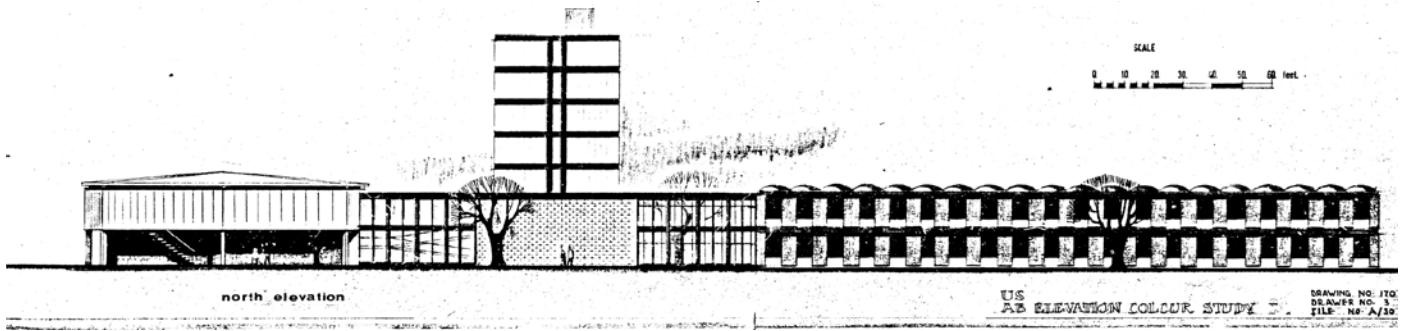

Figure 11. An undated elevation of the Arts Complex by Shore and Moffat Architects. Here the roof of the west classroom wing features repetitive arches rather than the saw-tooth roof that was constructed. Retrieved from Facilities Management Division Asset Record System, File A-30-T.

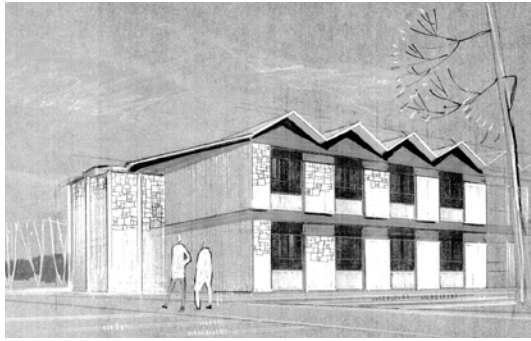

Figure 12. Perspective drawing of a portion of the west classroom wing and its saw-tooth roof. Retrieved from Facilities Management Division Asset Record System, File A-31-T.



Figure 13. Saw-tooth ceiling in the west classroom wing.

Conforming to the Modernist dictum ‘form follows function’, the Arts Complex is designed as a series of discrete wings or pavilions, differentiated by use: an office tower, a lecture theatre pavilion, and two classroom wings. The four components of the complex are arranged in plan in a rough cruciform, connected at their intersection by a glazed entrance lobby. Each part has a distinct form corresponding to its function. The office wing is an 11 storey tower, the theatre wing is an octagonal pavilion, the first classroom wing is a two-storey block with a distinctive saw-tooth roof, and the new classroom wing is a two-storey volume with a flat roof. The four parts of the complex are visible in Figure 10, although this early model shows the lower first phase of the tower, and the new classroom wing is not yet fully developed.

The four distinct parts of the Arts Complex were constructed in phases. The first phase consisted of a two storey classroom wing. The second phase added the first seven storeys of the tower, the lecture theatre and a link connecting the tower to the classroom wing. The third phase of construction added four storeys to the Arts Tower bringing its total height to 11 storeys. The final phase added a second classroom wing. In 1974 a pedestrian link was added to the Arts Complex to connect it to the [Thorvaldson Building](#) to the east.

The components of the complex are separated from one another but also connected by glazed lobbies and links. This use of glazing as a compositional device to allow the expression of separate functions is another common feature of Modernist architecture (Figure 6). The approach also serves to denote public and circulatory spaces.

The west classroom wing is a two-storey block defined by its distinctive saw-tooth roof (Figure 12). This use of repeated geometrical shapes to achieve a decorative effect is very common to Modernist architecture of the 1960’s. The roof form is carried into the interior as a motif used in the ceilings of the corridors (Figure 13).

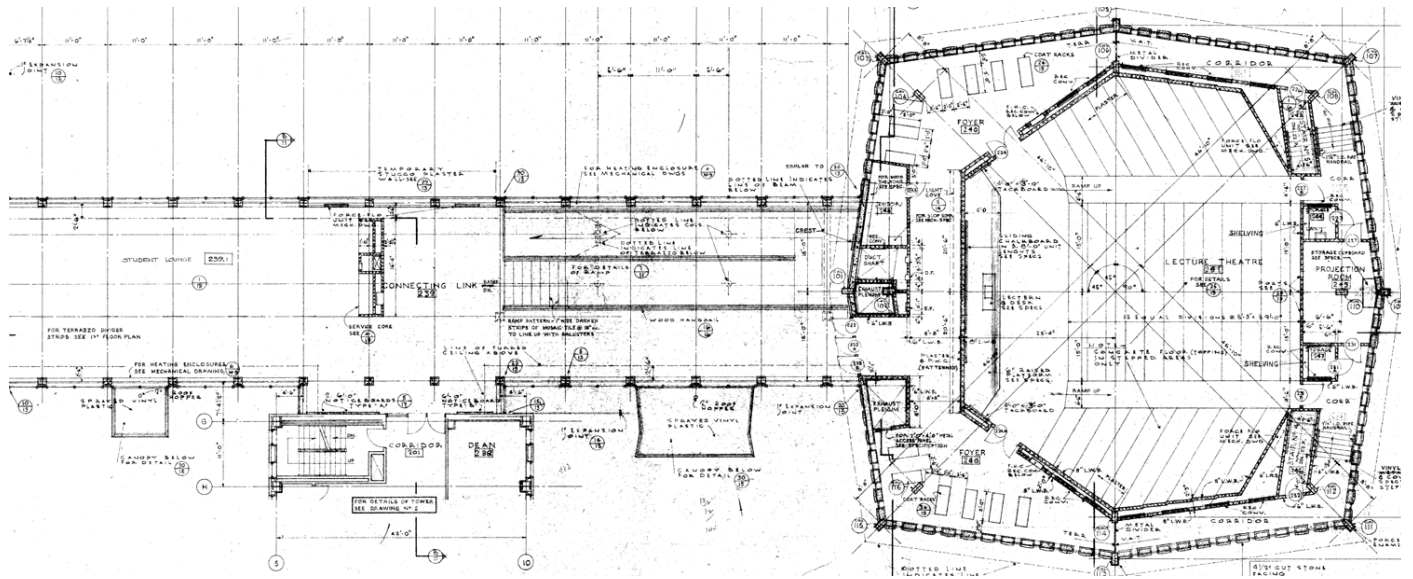

The theatre wing takes its form from the shape of the space it encloses (Figure 14). The octagonal theatre is wrapped by a larger octagonal volume, with the gap between them creating the required circulation and support spaces. The narrow windows that surround the theatre provide a muted light into the space surrounding the lecture hall. Shown in Figure 15, the quality and pattern of light provided by these windows is a character-defining element.

Figure 14. Plan of the Theatre Wing. Retrieved from Facilities Management Division Asset Record System, File A-339-AB.

The Arts Tower in its final form is shown in Figure 16. Its architects referred to the tower as a, “most attractive narrow slab tower,” (Billinton, 1995). It was intended to symbolize the central place of the arts at a university. The tower is a building form embraced by the architects of the modern period. It was rational in its structure and arrangement,



Figure 16. The 11 storey Arts Tower, 1985 photo. Photo A-10999 retrieved from <http://sain.scaa.sk.ca/>.

composed of near identical units repeated horizontally and vertically as required. It exploited the technologies of industrial construction and the capabilities of new materials. Steel and concrete could stretch to new heights and the elevator made it all practical. The Arts Tower, with its simple rectilinear form, its absence of applied ornament, its repetition of windows and stone panels as a compositional device, is an iconic example of Modernist architecture at the university and a character-defining element of the building (Figure 17).

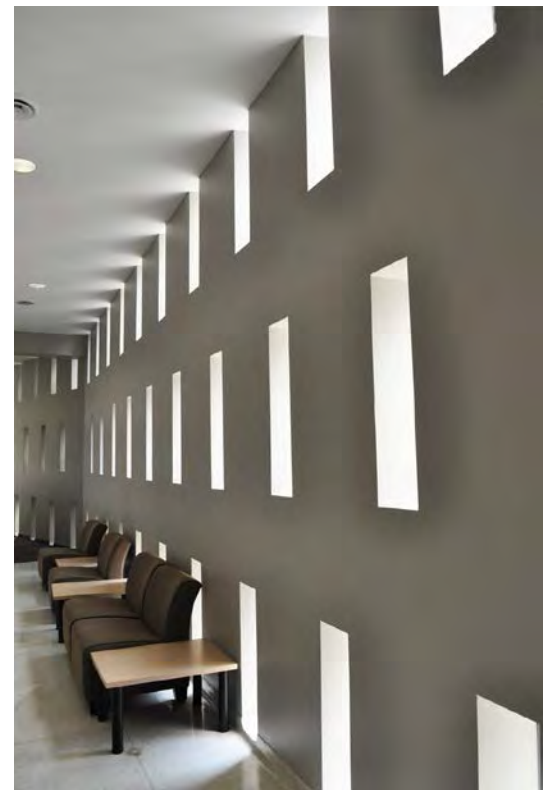

Figure 15. The quality of light provided by the narrow windows surrounding the theatre.



2.3 Location

Between 1954 and 1957, the Regina-based architectural firm of Izumi, Arnott & Sugiyama was engaged by the university to carry out a series of planning studies. This work was intended to address the issue of increasing traffic congestion, to suggest locations for a number of new buildings and to provide direction for the future growth of the campus. The adoption of Kyoshi Izumi's plan essentially marked the abandonment of the 1909 master plan by Architects David Brown and Hugh Vallance. The new plan involved the construction of a ring road (Campus Drive), and proposed the division of the campus into a series of functional precincts: Arts, Sciences, Medical, Agricultural and Residential. Locations were proposed for several new buildings, including a Biology building, some new residence halls, and a Humanities, or Arts complex (Figure 18).

Figure 17. The west side of the Arts Tower.

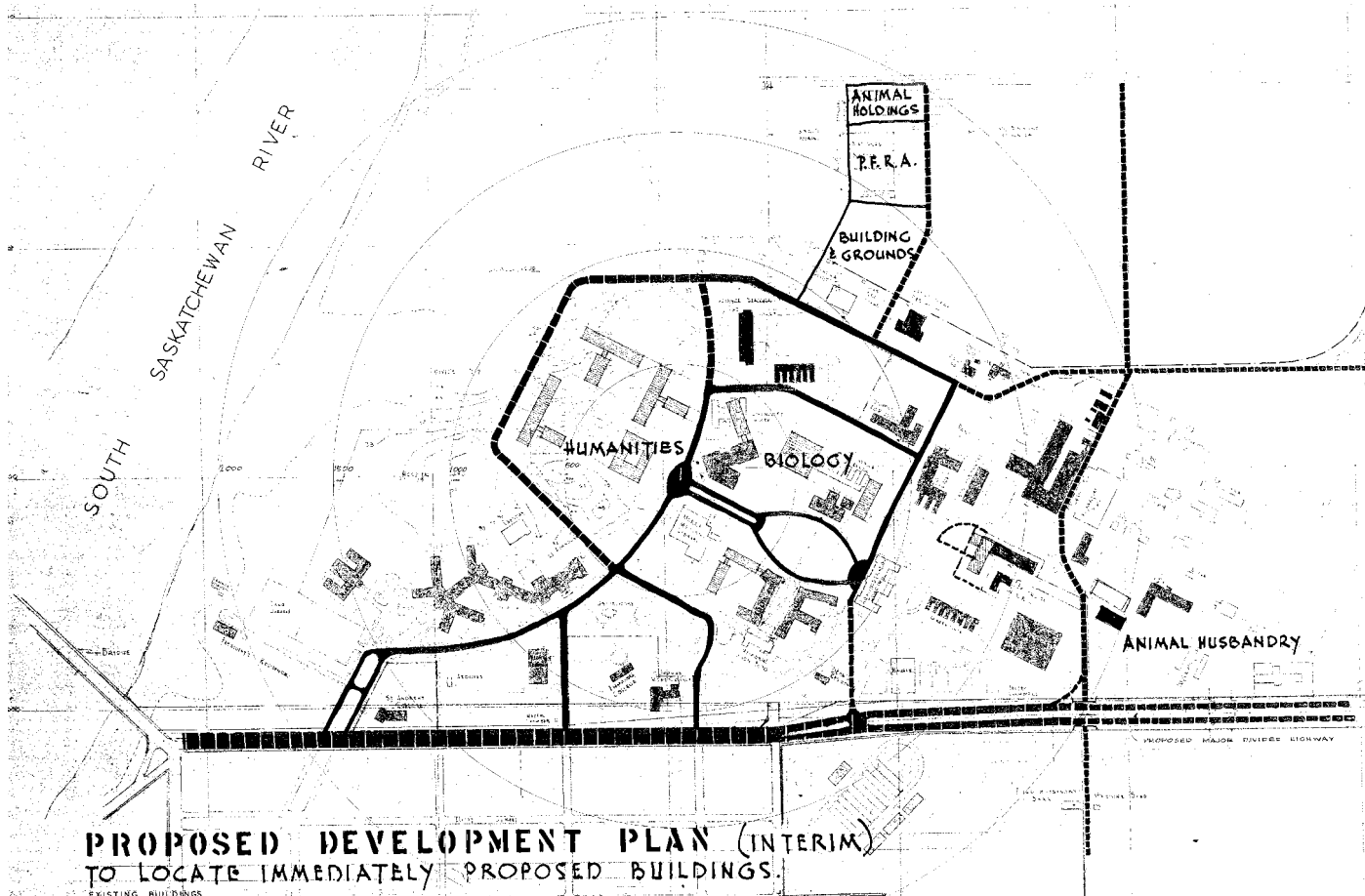

Figure 18. A proposed development plan dated June 18, 1957 from the office of Izumi, Arnott & Sugiyama. Retrieved from Facilities Management Division Asset Record System, File CG-23-T.

The general location of the Arts buildings was determined according to these planning studies, but its specific location was even more carefully considered. The main entrance to the Arts Complex was located to align precisely with the main entrance to the [MacKinnon Building](#), on the primary axis of the 1909 plan. It effectively terminated the axis of [The Bowl](#), concluded the period of development based on the 1909 master plan and signaled the beginning of a new modernist planning paradigm. The location and orientation of the Arts Complex with respect to other buildings is shown in Figure 19.

Notably, the first planned arts building, Haultain Hall, was also intended to occupy the approximate location of the Arts Complex, although it was laid out according to the original campus plan. Haultain Hall, designed by architects Brown and Vallance, was to have been located, “immediately west of the [Chemistry Building](#),” just north of where the Arts tower now stands. The location of the Arts Complex has heritage significance to both the 1909 master plan and the Modern period of campus planning.

2.4 Spatial Configuration

The Arts Complex is laid out as a series of connected but distinct building forms: an office tower, a lecture theatre pavilion, and two classroom wings. Each component of the complex has a different spatial configuration, according to its function. The connective spaces between these four components also have a particular spatial character.

The office wing is an 11 storey tower, long and narrow in plan, oriented roughly with its long axis running north-south. Individual offices arrayed on either side of a long double-loaded corridor. The first classroom wing is a two-storey block arranged east-west, with classrooms arranged on either side of a corridor. The theatre wing is a separate octagonal pavilion, containing only the theatre and some support spaces. The second classroom wing is an irregular two-storey volume. Two lecture theatres and several classrooms are arranged on the west side of its main corridor, with a block of laboratories and offices to the east.

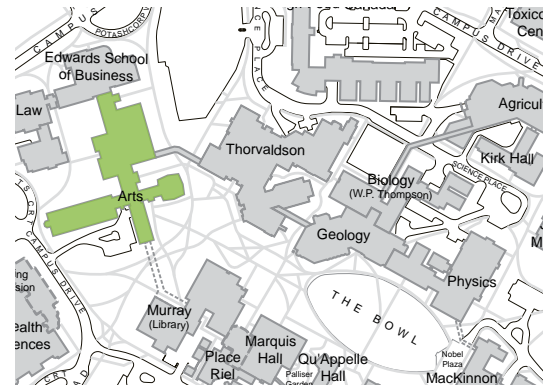

Figure 19. The location of the Arts Building is shown in green on this contemporary campus map.



Figure 20. Glazed circulation space.

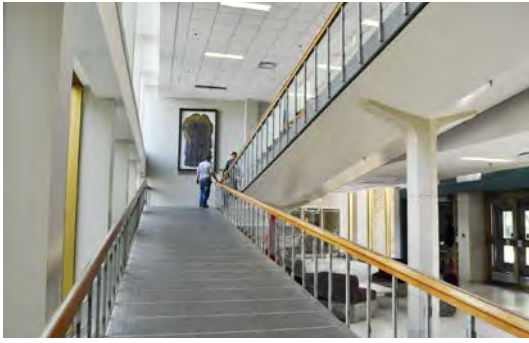

Figure 21. The 'Arts Ramp.'



Figure 22. Expressive structure under the 'Arts Ramp.'



Figure 23. The Arts Tower. The colonnade at the base is clad in grey porcelain enamel. The same material expresses the location of the floor plates above.

The connective and circulatory spaces of the Arts Complex are characterized by an extensive use of glazing, a corresponding quality of light and a strong connection to the outdoor spaces around the building (Figure 20). The main entrance lobby is located at the intersection of the four wings, and features a sculptural ramp connecting the ground floor to the second floor, and the entrance to the large lecture theatre (Figures 21 & 22). The Arts Ramp and its naturally lit lobby space are important character-defining elements.

The spatial configuration of the Arts Complex has been maintained to a high degree of commemorative integrity.

2.5 Systems

Various structural systems are employed in the Arts Complex, depending on the location.

The First Classroom Wing is constructed as a precast concrete system. A structural frame of precast columns and beams support precast concrete floor slabs, and a precast concrete folded plate roof structure. The foundation is cast in place concrete. Rough-faced greystone cladding is bonded to a cast-in-place concrete back-up wall. Tyndall stone panels are grouted in place against a brick back-up wall.

The tower is constructed with a structural steel frame, with concrete floor slabs. Concrete is also used as a fire-proofing material around the steel frame. The Arts Complex was intended to be constructed in two phases, ultimately reaching 10 storeys in height. The first phase, completed in 1960, created a seven storey structure. Three additional storeys were planned, but in the time between 1960 and 1963, advances in structural engineering enabled the architects, Shore and Moffat, to add an extra floor to the design. The tower was completed in 1965, at 11 storeys in height.

The Theatre Wing is constructed almost entirely of cast-in-place concrete. Foundations, columns, beams, floor slabs and walls are all cast-in-place, but the roof structure is steel. The Second Classroom Wing is constructed with a steel structural frame.

The exposure or expression of structure is a common feature of modern architecture, and while not rigorously pursued, is employed in the Arts Complex. On the tower, the structural grid is revealed at the base of the building, where its glazed skin is pulled back to create a colonnade. The columns are clad in grey porcelain enameled panels, which also denotes the location of the floor slabs on the front elevation of the tower (Figure 23). The structure supporting the ramp is particularly expressive (Figure 22). The ramp is a cast concrete structure supported by hexagonal columns, clad in terrazzo so that they appear to grow out of the floor. The expression of structure is a character-defining element of the Arts Complex.

2.6 Use(s)

The Arts Complex is used primarily by the College of Arts and Science supporting teaching and research in the humanities and social sciences. This has been its purpose since its construction. It contains classroom, lecture theatres and laboratories. 22 departments of the College of Arts and Science are accommodated in the complex, including English, History, Economics and Geography. The Arts Tower is used for administrative purposes, housing faculty and departmental offices. The original plans show that the space was intended for use as offices as well as faculty lounges, departmental rooms, student society rooms and staff lounges. The Arts & Science Students' Union (ASSU) is now housed on the second floor of the west classroom wing. The university bookstore originally occupied space on the first floor of the building after its construction, but is now located in Marquis Hall. The use of the Arts Complex for education and administration of the humanities and social sciences are character-defining elements.

2.7 Cultural & Chronological Associations

The Arts Complex can be associated with the history of the College of Arts and Sciences at the University of Saskatchewan. A building to house the arts was intended for the campus at a much earlier date. A College of Liberal Arts and Science had been on President Murray's list of proposed buildings for the campus in 1909. As early as 1913, preliminary drawings were prepared. In 1930 plans were drawn by University Architects David Brown and Hugh Vallance, and put out to tender. Named Haultain Hall for Sir Frederick Haultain, the University's second Chancellor, the \$886,000 building was proposed in the estimates for the 1930-31 year. It would have housed Arts, Biology, Household Science, Accounting, Education, administrative offices, a gym, a library and a museum. Figure 24 shows a front elevation of Haultain Hall. The provincial government delayed the building for one year due to the economic depression. By 1933 the conditions in the province had only worsened and the project was cancelled. It was not until Canada Council funding became available 25 years later that the current Arts Complex became possible.

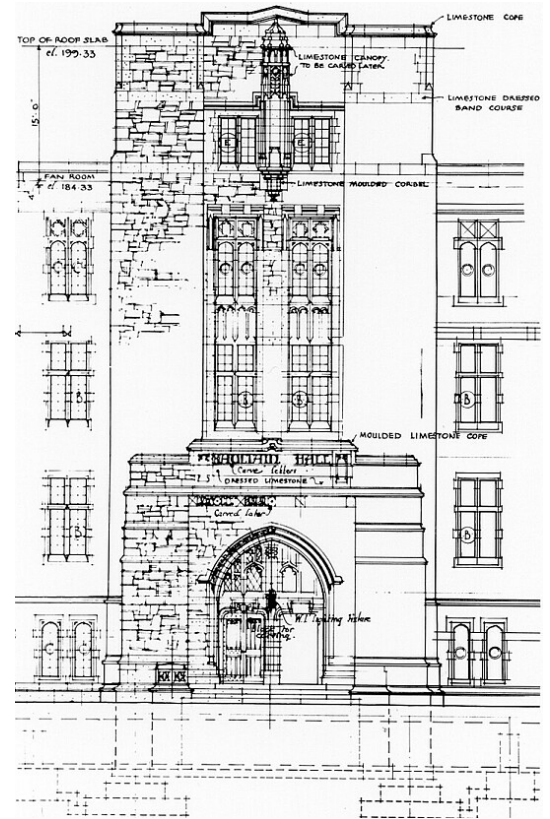

Figure 24. Front elevation of Haultain Hall. Photo A-6503, retrieved from University of Saskatchewan Archives.



The Arts Complex can be associated with the chronological and social milieu in which it was built. In the 1960's, Canadian universities, "had become increasingly important during the post-World War II economic and technological boom and, coupled with the demands created by the enormous size of the baby boom generation, expanded dramatically during this period." (Lexier, 2007). The University of Saskatchewan was no exception. The student population of the university increased from 3,961 to 10,181 between 1958 and 1970 (Hayden, 1983, pp. 250). Not only was the student population larger, but student demands were changing. Students were gaining heightened awareness of issues external to the sphere of the university. Students were inspired by movements aiming for societal change and agitated for more democratic universities (Lexier, 2006).

Up until this time, an arts building had remained conspicuously absent at the University of Saskatchewan. The lack of such a building was atypical. The construction of the Arts Building in the 1960's can be seen as a reflection of the time. A large, Modern building dedicated to the humanities reflected the socially minded student body of the 1960's. The size of the building and its configuration to allow for additions associates it with post World War II population growth.

3. Associated Objects

N/A

4. Supporting Documents

Billinton, S. (September 22, 1995). Haultain Hall: The Arts Building That Never Was. *On Campus News*, .Retrieved from http://www.usask.ca/archives/history/ocn_22sep1995-haultain.php

Facilities Management Division (2012). Asset Resource Database [Data File]. Retrieved from \\usask\fmddfs\files\iis\IIS_Public\ARS

Hayden, M. (1983). *Seeking a Balance: University of Saskatchewan, 1907-1982*. Vancouver: University of British Columbia Press.

Lexier, R. (2007). The Backdrop Against Which Everything Happened. *History of Intellectual Culture*, 7 (1). Retrieved from <http://www.ucalgary.ca/hic/issues/vol7/3>

University of Saskatchewan Archives. (Retrieved 2012). *Campus Buildings: Arts Building*. Retrieved from http://scaa.sk.ca/gallery/uofs_buildings/

University of Saskatchewan Archives. (Retrieved 2012). *Campus Views: Of What Never Was*. Retrieved from http://scaa.usask.ca/gallery/uofs_buildings/



5. Summary of Character - Defining Elements



Materials

- Tyndall stone cladding
- greystone cladding
- gold anodized aluminum-framed glazing
- porcelain enameled spandrel panels and column covers
- terrazzo flooring
- wooden paneling
- interior brick walls and flooring

Form & Style

- simplified forms
- repetition of geometrical shapes for decorative effect
- expression of function
- expression of structure
- formal massing of discrete wings, differentiated by function
- glazed lobby and links
- tower
- classroom wings
- Neatby-Timlin lecture theatre
- cruciform plan
- saw-tooth roof
- material continuity between exterior and interior

Location

- location in relation to 1954-57 planning studies
- location in relation to 1909 campus plan

Spatial Configuration

- four connected but discrete building forms, differentiated by function
- glazed lobby and links
- double loaded corridors in tower & classroom wings
- main lecture theatre

Uses

- education in arts and sciences
- faculty offices
- student offices

Cultural & Chronological Associations

- College of Arts and Sciences
- Haultain Hall

064

John Mitchell Building

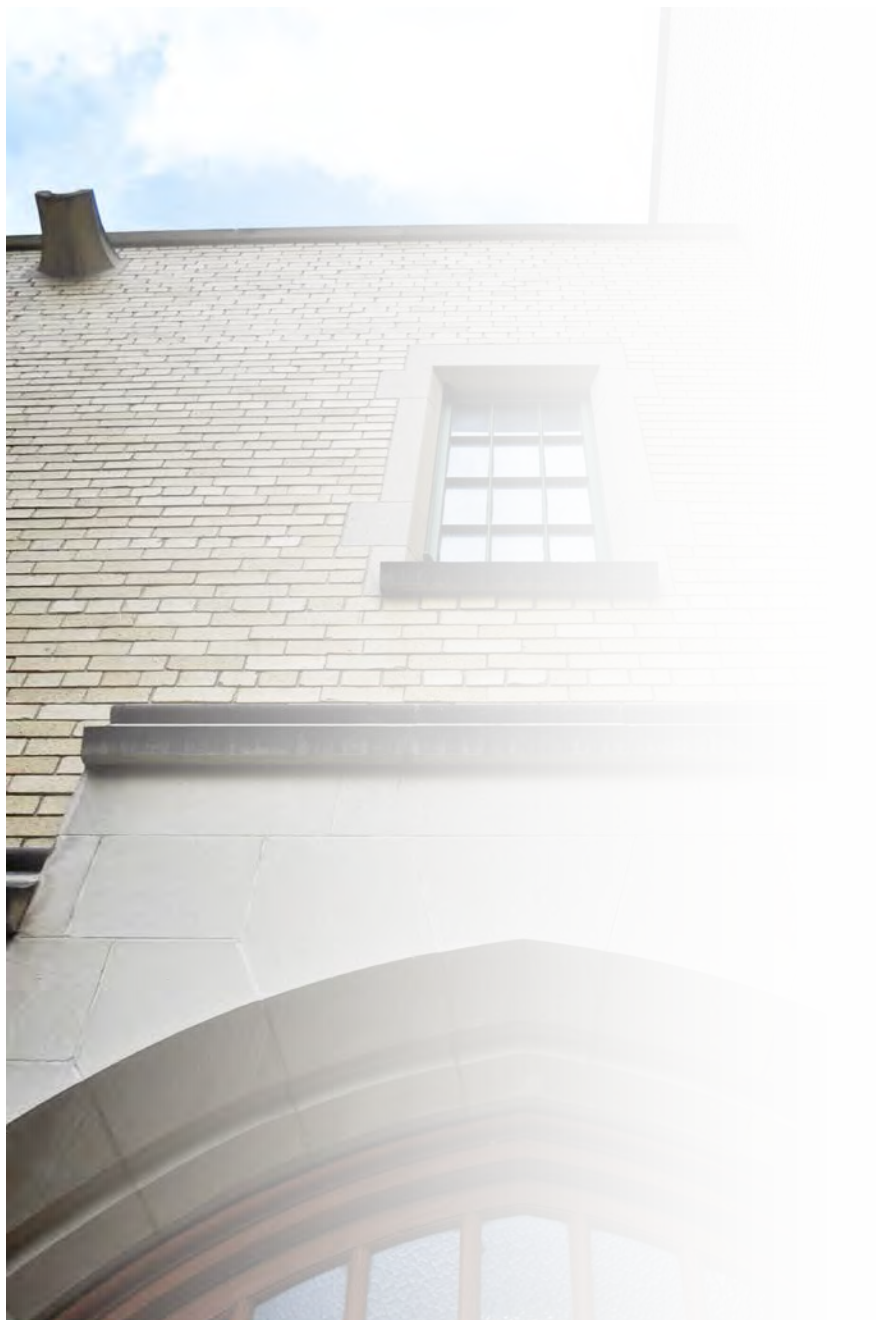

064

John Mitchell Building

Alternate Names

Soils and Dairy Building

Architect(s)

Frank J. Martin, Portnall and Stock Associated Architects, Regina and Saskatoon

Builders

Department of Public Works

Construction Dates

1949

Recognition

N/A



Figure 1. Yellow brick showing some spalling.



Figure 2. Limestone string course.



Figure 3. L to R: brass door hardware, oak, yellow brick.

1. Statement of Significance

The John Mitchell Building was one of two structures at the University of Saskatchewan designed by Frank J. Martin of Portnall and Stock Architects, and built at the same time, between 1947 and 1949. [Kirk Hall](#) and the John Mitchell Building share many similarities. Constructed in yellow brick, John Mitchell was originally used for agricultural education & research, and was located among other buildings housing the College of Agriculture. The building was initially named the Soils and Dairy Building for its intended uses. It was renamed the John Mitchell Building in 1957 after a prominent faculty member and former student of the College of Agriculture. The building was used by the College of Agriculture until 1991, when the current Agriculture Building opened. In 1993 the building was adapted to house the Department of Drama.



Figure 4. The John Mitchell Building, 1948. The Archaeology Building is in the background. Kirk Hall is partially visible in the foreground. Photo A-466, retrieved from http://scaa.usask.ca/gallery/uofs_buildings/.

The John Mitchell Building is designed in a simplified Collegiate Gothic style characteristic of the architecture of the University of Saskatchewan campus in the immediate post-war period. It has some heritage significance for this reason and for the commemorative integrity of its material, form and spatial configuration.

Note: The John Mitchell Building is configured with floors numbered Basement, Ground Floor and First Floor. This report follows the same convention.

2. Character - Defining Elements

2.1 Materials

The exterior of the John Mitchell Building is faced in yellow brick, with Indiana limestone trim and a base of grey granite. Yellow brick was used at the time to denote agricultural buildings, such as the Virus Laboratory (now demolished) and Kirk Hall. The condition of the exterior of the John Mitchell Building is generally good; however, some of the brick is beginning to spall (Figure 1). The use of limestone for cut stone decoration and granite as a base was common at the university in this period. The limestone has some surface staining evident on the string courses (Figure 2). (For further information on building stones used at the U of S, refer to 'Appendix: Stone'.)



Figure 5. L to R: brass window clasp, painted steel sash window.



Figure 6. Glass block windows.



Figure 7. Exterior window materials: steel sash window, limestone surround and yellow brick wall.



Figure 8. L to R: Interior brick, terrazzo stair treads.



Figure 9. Glazed ceramic tile.



Figure 10. Maple door with brass hardware.

Exterior doors and frames are oak (Figure 3). The primary entrance doors have been replaced, but their frames are original. Windows are single-glazed with painted rolled steel frames. Two sets of windows are provided for each opening; an interior set composed of two large panes and an exterior set with multiple divisions. Window hardware is painted steel and brass (Figure 5). Two spaces, formerly a dairy and a soils lab, but now used as drama studios, feature large windows composed of 8" glass block (Figure 6). Yellow brick, Indiana Limestone, granite and oak are character-defining materials (Figure 4). The painted steel-framed windows and glass block windows are also character-defining and are both in excellent commemorative condition.

On the interior, corridor walls feature brick as a wainscoting, with painted plaster walls and ceilings above. The interior brick is predominantly yellow, but as shown in Figure 8, corners are accentuated with red brick. Other interior materials include terrazzo flooring and window sills. The interior brick and terrazzo are in excellent commemorative condition, with the exception of a few instances where the terrazzo flooring has been replaced with vinyl composite tile (VCT). The studios now feature sprung flooring raised above the level of the corridor flooring. The original terrazzo flooring likely still exists underneath. The washrooms retain their character-defining wainscoting of blue and white glazed tile as do the surrounds for the drinking fountains in the hallways. This tile, shown in Figure 9, is in excellent commemorative condition. The walls of the north and south studios have glazed tile wainscoting that has been painted.

On the interior, doors and frames are in maple, and windows also have maple trim (Figure 10). Many rooms also feature a maple dado rail (Figure 11). The doors exist in varying states of commemorative integrity. Most appear to be original. Most of the original door hardware has been maintained; these brass knobs and hinges are character-defining elements.



Figure 11. Maple door frame and dado rail.



Figure 12. Staircase materials: steel stringers, risers and balustrade with terrazzo treads and landing.

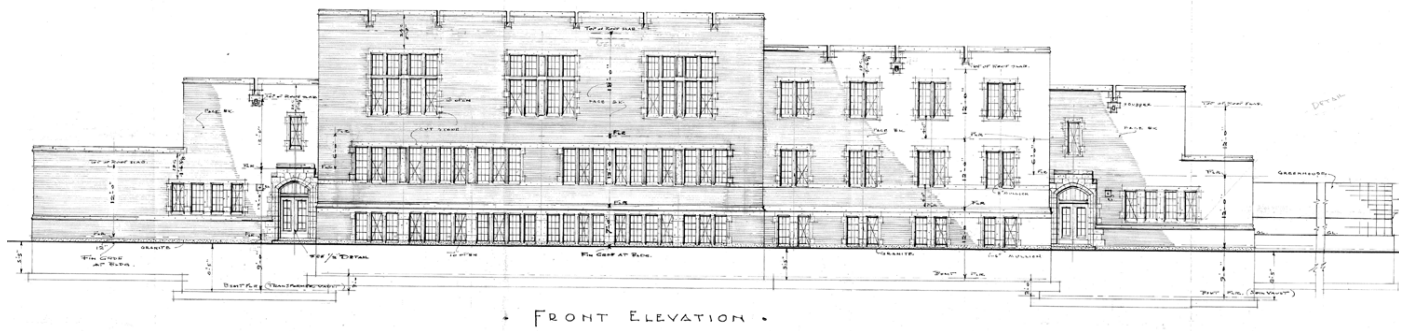

Figure 13. Front elevation of the John Mitchell Building depicting asymmetry and uneven roof plane. Retrieved from Facilities Management Division Asset Record System, File J-5-T .

The staircases (Figure 12) consist of metal risers, stringers and balustrade accompanied by an ‘alumilite’ handrail, with terrazzo treads and landings. These materials exist in good commemorative condition and are character-defining elements.

2.2 Form & Style

The John Mitchell Building is composed of three wings forming a C-shape in plan. The central wing is two and a half storeys in height, while the north and south wings vary between one and two storeys. The roofs are all flat. The front elevation is stepped both in plan and section, such that the central bay projects forward and is the tallest element of the composition. The north and south wings step down in section and back in plan. The arrangement is slightly asymmetrical, as illustrated in Figure 13.

Originally, the south side of the building served as a header house for three greenhouses, now demolished, that extended from that side of the building (Figure 14).

The form of the John Mitchell Building has good commemorative integrity, despite the removal of the greenhouses and the addition of a scenery workshop to the end of the south wing.

The John Mitchell Building was designed in a simplified Collegiate Gothic style. Simplified or ‘stripped’ versions of gothic and classical architectural styles were common during the 1940’s, both in Canada and internationally. In the immediate post-war period several buildings were designed with this approach at the University of Saskatchewan, including [Kirk Hall](#) and the original Griffiths Stadium.



Figure 14. The form of the John Mitchell Building with the original greenhouses appended to the south side. Photo A-468 retrieved from University of Saskatchewan Archives.



Figure 15. L to R: ornamented lantern, transom in the form of a gothic arch.



Figure 16. Limestone string courses and window surrounds.



Figure 17. Factory-style windows on the south side of the building.



Figure 18. Gothic arch motif on door.

The familiar characteristics of the Collegiate Gothic style are all present in this building, but are fewer in number and are simplified in detail compared with earlier examples of this style. Windows are rectangular rather than arched, but still feature cut stone trim on the front elevation. The exterior windows are composed of multiple panels, in keeping with earlier precedent, although notably the interior windows have larger panes. The principle entrances feature gothic arched openings, and lanterns, both illustrated in Figure 15. The roofs are flat, but their parapets still feature a crenelated profile. Cut stone string courses and scuppers add some detail to otherwise unadorned walls (Figure 16). There is cut limestone trim and quoining around each window.

Exterior elements forming part of the simplified Collegiate Gothic expression of the building, including crenelated parapets, cut stone decoration and window trim, multi-paned steel framed windows and arched entrances, are character defining.

In a few discrete instances, contemporary elements crop up in the design. The large square windows on the south side of the building, in the space originally used as the header house for the greenhouses, are reminiscent of early twentieth century factory buildings and warehouses (Figure 17). The glass block windows of the dairy (now studios) and soils lab, have a similarly modernist appearance (Figure 6).

Interior ornamentation is limited, but features several gothic motifs. Some of the interior paneled wooden doors feature a top rail shaped as a gothic arch (Figure 18). Stairs feature newel posts in the shape of a pointed arch (Figure 19). Also visible in Figure 19 are dark red bricks forming quoining at the corners of a yellow brick wainscot. The gothic motifs on the interior are character-defining elements.

2.3 Location

The John Mitchell Building was located as part of a precinct of buildings serving the College of Agriculture, which at the time included the School of Agriculture Building (now [Kirk Hall](#)), and the Field Husbandry and Crop Science (now [Archaeology](#)) Building (Figure 20). The location of the John Mitchell Building, near Kirk Hall and the current College of Agriculture, is therefore a character-defining element. Figure 21 illustrates the current context of the John Mitchell Building.

The John Mitchell Building is arranged on each of its floors around central double-loaded corridors matching the C-shaped configuration of its floor plans. At either end of the corridor in the central wing, stairs lead to the north and south wings, whose floors are set a half-storey lower than those of the central wing (Figure 22). This split level design is a character-defining element of the building's spatial configuration.

The John Mitchell Building originally included several large laboratory spaces that were converted into studios when the building was adapted for use by the Drama Department in 1993. On the ground floor, the north and south wings each terminated in large, double-height rooms. The dairy in the north wing became the Greystone Theatre and a soils laboratory in the south wing became a 'black box' style theatre studio. Although these rooms are no longer laid out in their original configurations, their materiality has been substantially altered to configure them as performance spaces. However, their size, open floor plan and glass block windows are character-defining elements that have been maintained. Figure 23 shows the ground floor plan as it was configured originally, and Figure 24 shows the current configuration. The glass block windows on the north side of the south studio have been obscured by the addition of a corridor space (Figure 25), but still remain in place.

Figure 22. Longitudinal section through the John Mitchell Building showing split level configuration. The largest space is the Hangar Studio or former Bacteriology Lab. Retrieved from Facilities Management Division Asset Record System, File J-3-T.

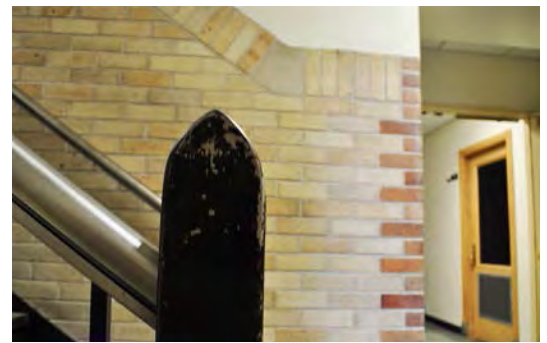
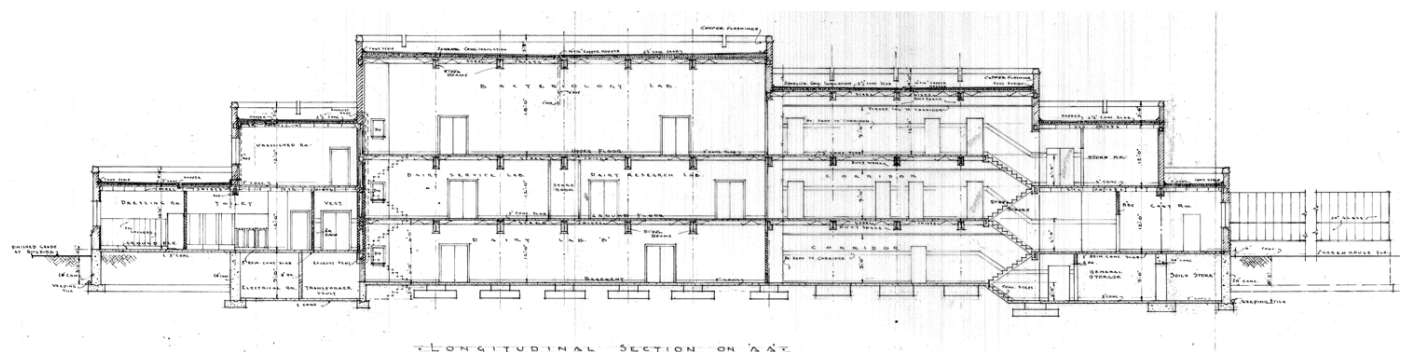

Figure 19. Gothic arch motif on newell post.



Figure 20. The location of the John Mitchell Building on a site plan current at the time of its construction.

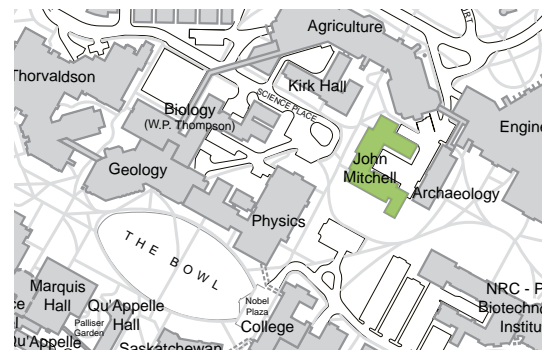

Figure 21. The location of the John Mitchell Building is indicated in green on a contemporary campus map.

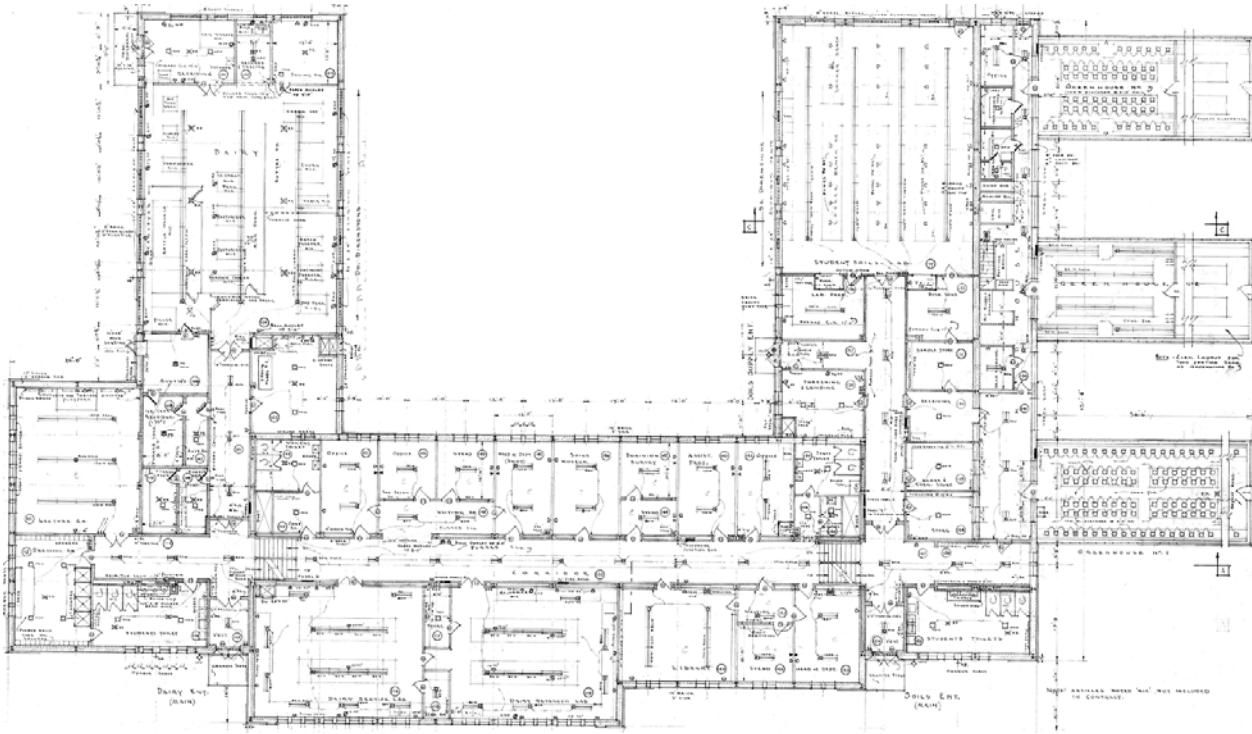

Figure 23. The first floor plan of the John Mitchell Building showing original configuration and uses. Retrieved from Facilities Management Division Asset Record System, File J-7-T.

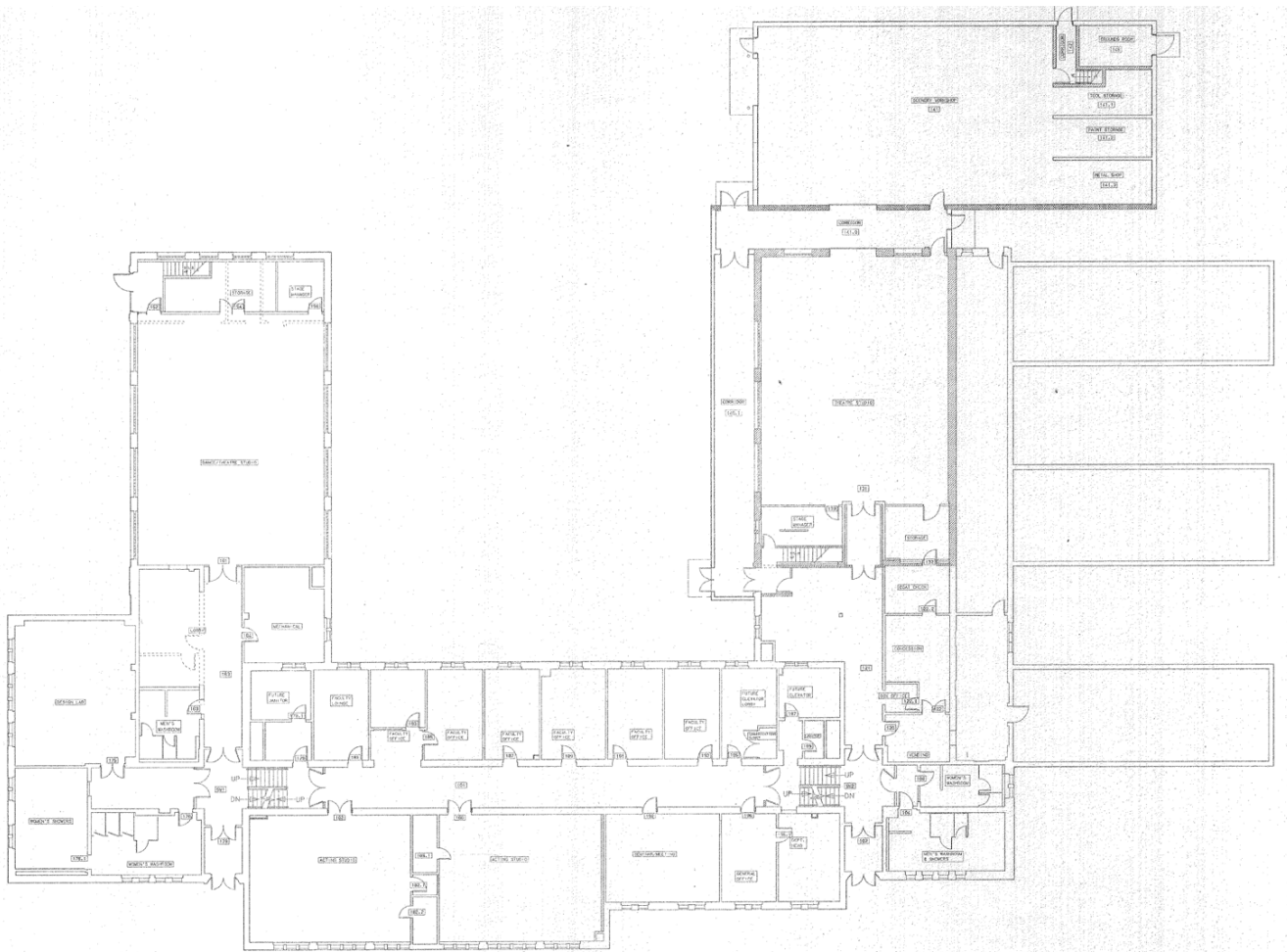

Figure 24. The first floor plan of the John Mitchell Building with the 1992 addition. Retrieved from Facilities Management Division Asset Record System, File 064-278-C.

On the first floor, a double height space at the front of the building contained a bacteriology lab. It is now known as the 'Hangar Studio' and is used for instruction in drama and dance. (The name 'Hangar Studio' likely derives from the former home of the Drama Department, the Hangar Building, which was demolished in 1994). This room has retained its high ceiling and tall windows, which are character-defining elements. Figure 22 illustrates the space in section. Figure 26 is a recent photograph.

2.5 Systems

The structure of the John Mitchell Building is a structural steel frame, consisting of steel joists, beams and columns on cast-in place concrete foundation walls and footings. Floors and roofs are 3" concrete slabs on steel joists. Exterior walls are non-structural and consist of 13" of brick, with a 3" layer of hollow clay tile and painted plaster. One inch of cork insulation was provided in the walls behind radiators.

The stairs leading from the basement level to the ground floor at either end of the central wing feature metal ramps that can be lowered into place over the stair treads. They were originally used to help with the moving of soils and dairy materials between floors. The ramps are still functional and exist in good commemorative condition. Figure 27 shows the ramps in the upright position.

As the building was used for research, its floor plans show several provisions that are no longer in place. These include fume cabinets, nitrogen and a centrifuge. The original plans also show that a dumbwaiter originally existed in the north wing, but this is no longer in existence.

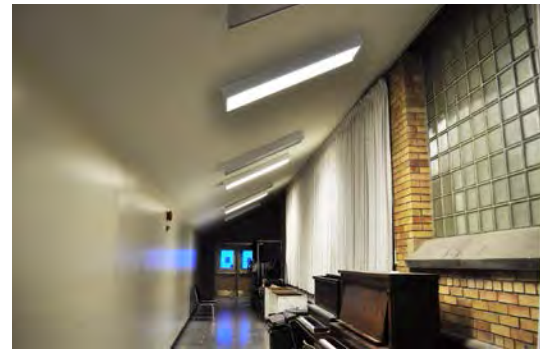

Figure 25. An addition encloses the north side of the south studio.



Figure 26. The Hangar Studio's double height ceiling and windows.



Figure 27. Stair with retractable ramp.



Figure 28. Judging butter in a dairy lab, ca. 1960. Photo A-1840, retrieved from http://scaa.sk.ca/gallery/uofs_buildings/

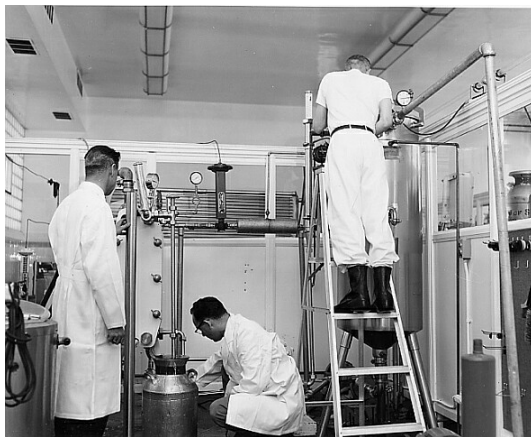

Figure 29. Lab in the Dairy and Food Science Department, 1960. Photo A-1838, retrieved from http://scaa.sk.ca/gallery/uofs_buildings/



Figure 30. Theatre space in the former dairy and soils labs, 1997. Photo MG-245, retrieved from http://scaa.sk.ca/gallery/uofs_buildings/

2.6 Use(s)

The John Mitchell Building was originally named the Soils and Dairy Building after its first purpose. The building housed lecture rooms, seminar rooms and labs for education and research into the dairy and soil sciences. For the most part, the north half of the building was devoted to dairy sciences and the south half was used for soil study. The original plans, shown in Figures 23 and 24, indicate the intended uses of the rooms. Since 1993, the building has been used as the home of the Drama Department.

The dairy half of the building included two dairy labs and a physical lab located in the basement. Figures 28 and 29 show the dairy lab in use. Also in the basement were a soil vault and a dark room. The basement dairy labs are now used for costume design. On the ground floor, the two dairy labs on the west side of the central wing are now known as Studios A and B and are used for drama and dance rehearsal. The ground floor lecture room is now a design studio. The large dairy in the north wing, now the Greystone Theatre, was also used as a cheese lab and at the time of the buildings conversion was used as a smoked meat lab.

The soil science portion of the building originally included rooms for lecture, maps and references, drafting, washing and sterilization. A seminar room and a storage room that existed at the south end of the first floor have been combined into a lighting lab where students practice hanging and adjusting stage lighting. The former maps and reference room has been reclaimed as a student lounge. Office space for Student Information Systems is located in a former bacteriology lab and a lecture room. The drafting room is now used as an archival space for the drama department. On the ground floor, the large soils lab is now a black-box theatre space. Figure 30 shows this space in use as a drama performance and practice space. The former header house space is now used for storage, and the greenhouses no longer exist. Figure 31 shows the greenhouses being used. On both the ground and first floors, faculty offices are still used in this capacity.

Because the uses of the John Mitchell Building have changed substantially in their conversion from the agricultural sciences to drama, there is no heritage value in its current uses.

2.7 Cultural & Chronological Associations

The John Mitchell Building is associated with its namesake and with the College of Agriculture. John Mitchell graduated from the College of Agriculture at the University of Saskatchewan in 1924 and joined the soil survey that same year. He became an instructor in the College of Agriculture in 1925 and was appointed professor and Head of the Department of Soils in 1934, positions that he held for the rest of his career. He was the first president of the Saskatchewan Agricultural Graduates Association, and was inducted into the Saskatchewan Agricultural Hall of Fame.

3. Associated Objects

A plaque mounted in the southern entrance vestibule commemorates the dedication of the building to John Mitchell (Figure 32).

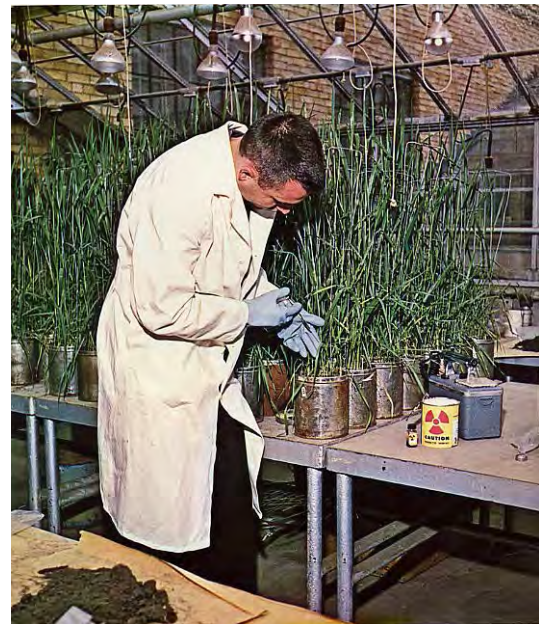

Figure 31. The soils department using the greenhouses, 1962. Photo Greystone-1962, retrieved from http://scaa.sk.ca/gallery/uofs_buildings/



Figure 32. Plaque commemorating John Mitchell.

4. Supporting Documents

Anderson, D. (Retrieved 2012). *The Encyclopedia of Saskatchewan, Mitchell, John (1897-1955)*. Retrieved from http://esask.uregina.ca/entry/mitchell_john_1897-1955.html

Facilities Management Division (2011). Asset Resource Database [Data File]. Retrieved from \\usask\fmddfs\files\iis\IIS_Public\ARS.

University of Saskatchewan Archives. (Retrieved 2012). *Campus Buildings: John Mitchell Building*. Retrieved from http://scaa.sk.ca/gallery/uofs_buildings/



5. Summary of Character - Defining Elements

Materials

- yellow brick walls and wainscoting
- Indiana limestone trim and decoration
- white and blue glazed ceramic wall tile
- maple doors, frames, window surrounds and dado rails
- steel window frames
- steel and terrazzo stairs
- terrazzo flooring, and window sills
- brass fixtures

Form & Style

- asymmetrical massing
- scale
- gothic arched door rails, transoms and newel posts
- ornamented lantern
- interior and exterior quoins
- glass block windows
- windows with multiple lites
- uneven roof plane
- assymetry
- limestone string courses
- scuppers
- crenellated parapet

Location

- University of Saskatchewan
- Part of 'Agricultural Precinct'

Spatial Configuration

- double loaded corridors
- large open lab spaces
- split level

Systems

- steel structure
- fold-up ramps

Uses

- dairy research
- milk, cream and cheese production
- soils research
- agricultural education
- laboratories

Cultural & Chronological Associations

- John Mitchell
- College of Agriculture



076

Seed Barn



076

Seed Barn

Alternate Names

Crop Science Seed Barn
Field Husbandry Barn
Feed Barn

Architect(s)

Unknown

Builders

Unknown

Construction Dates

ca. 1915

Recognition

N/A

1. Statement of Significance

Estimated to have been built in 1915, the Seed Barn was first owned by the federal government before the University of Saskatchewan acquired it in the mid 1950's. The designer and builder are unknown, but the style of the barn is typical of North American dairy and livestock barns of the early twentieth century. This particular barn was first used as a horse barn, then as a seed storage barn, and is now used as a storage facility by the Department of Plant Sciences. The Seed Barn has heritage value as a characteristic example of an early twentieth century livestock barn, and as an iconic structure related to the history of agricultural education at the University of Saskatchewan.



Figure 1. Painted cedar shingles and siding.



Figure 2. The Crop Science Seed Barn. Photo retrieved from <http://thesheaf.com/2012/01/25/>

2. Character - Defining Elements

2.1 Materials

The Seed Barn is a wooden structure on a raised cast-in-place concrete foundation. The exterior walls of the building are clad in painted cedar shingles and painted horizontal cedar siding (Figure 1). The barn is now painted white, but a black & white photograph dated circa 1924 indicates that the shingles were originally either painted a darker colour, or were unpainted. The same photograph shows a concrete ground floor wall, which has since been replaced with a wooden structure. The roof was likely clad originally in cedar shingles, but these have been replaced with asphalt shingles. Rafter ends are exposed at the eaves and are shaped for decorative effect (Figure 3). The barn features painted wooden sash windows and painted wooden doors. Many of the doors have been covered with plywood on the exterior. Original exterior materials such as cedar shingles, exposed rafter ends, wooden sash windows and wooden doors are character-defining elements.

The interior of the building is also characterized by wooden materials: Douglas fir walls, floors, stairwells, columns, beams and partitions. Figure 4 shows the Douglas fir stair treads and wall paneling. The fir is generally unpainted and in good condition. Some of the interior wooden walls and columns have been painted. Some of the wood, especially in the hayloft, shows signs of minor water damage (Figure 5). Unpainted fir is a character-defining element.



Figure 3. Exposed, profiled wooden rafter ends.



Figure 4. Douglas fir interior walls and stairs.



Figure 5. Fir roof decking showing signs of water ingress.



Figure 6. Red brick chimney, now removed.



Figure 7. The distinctive slope of the Gambrel style roof.



Figure 9. Dormer windows and Gambrel roof.



Figure 10. Interior view of peaked dormer.



Figure 8. The Crop Science Seed Barn, ca. 1924. Photo A-78, retrieved from <http://sain.scaa.sk.ca/items/index.php/university-of-saskatchewan-archives;jsdiah>

2.2 Form & Style

The Seed Barn is typical of North American dairy and livestock barns of the early twentieth century. Gambrel roofs, roof ventilators and dormers, and multiple windows are the distinctive features of this style of barn, which became popular in the United States and Canada around 1850. Gambrel roofs have a shallow slope near the peak of the roof and a steeper pitch near the eaves (Figure 7). This roof shape was developed to create more space in the loft. The gambrel roof form is seen also on the nearby [Stone Barn](#). The Seed Barn also features roof ventilators, visible in Figure 8, and dormer windows (Figure 9). A large set of loft doors permit the direct loading of hay into the loft from the exterior (Figure 9). Originally, these loft doors could be accessed from an earth ramp on the exterior, as illustrated in Figure 8. The gambrel style roof, roof ventilators, dormer windows and loft doors are character-defining elements of the Seed Barn.

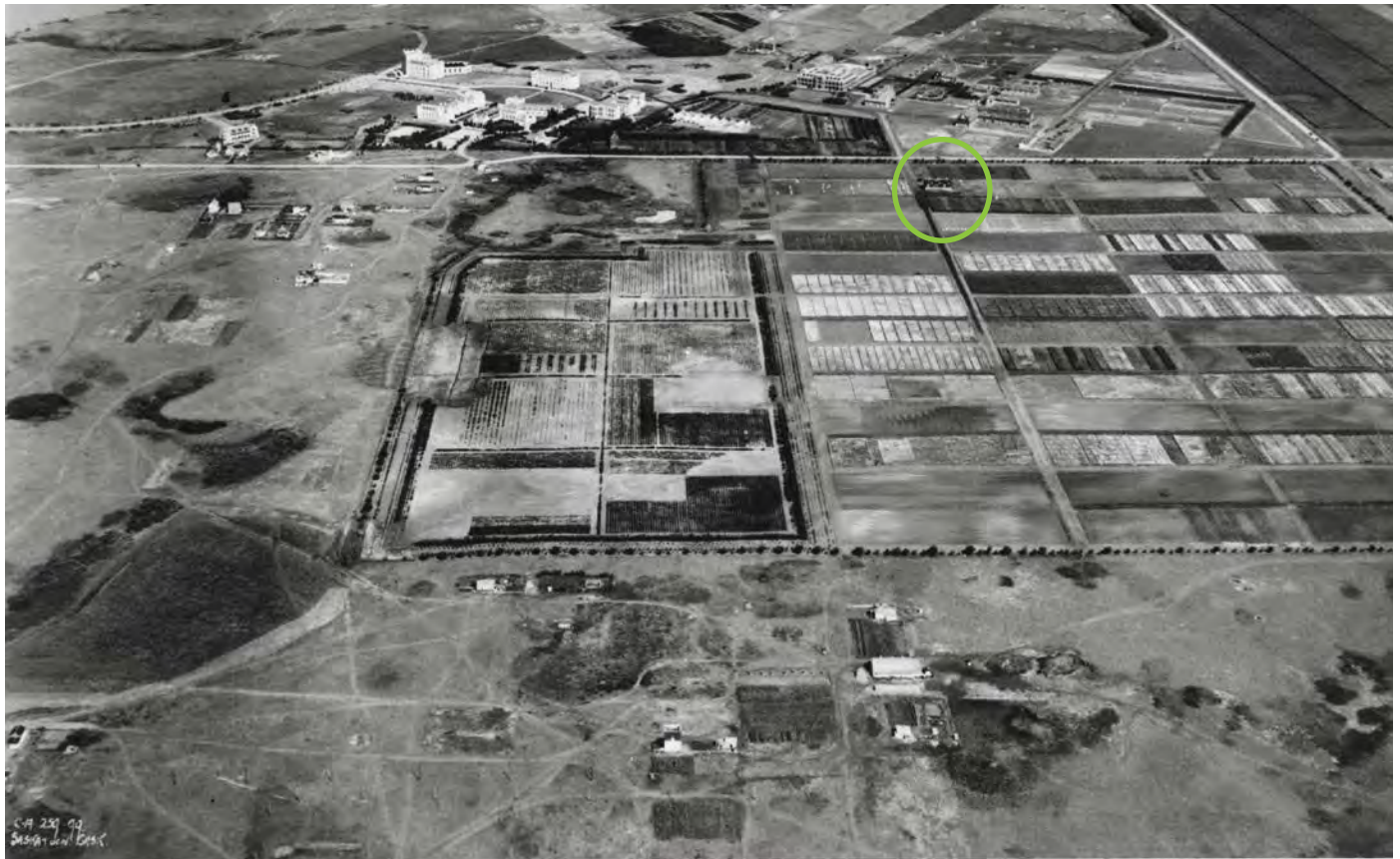

Figure 11. Aerial photo of the University of Saskatchewan, 1924-1928. The Crop Science Seed Barn is visible in the upper right of the photo and is indicated by the green circle. Note that College Drive has realigned further to the south since the date of this photo. Photo A-184, retrieved from University of Saskatchewan Archives.

2.3 Location

As attested to by early photographs, the Seed Barn was historically located south of College Drive. Figure 11 shows a photograph taken between 1924 and 1928, in which the Seed Barn sits in its original location. College Drive has since been widened and realigned closer to the original location of the Seed Barn. An earlier photograph, Figure 8, shows the Seed Barn, in its original location, with the [Stone Barn](#) in the background. Although the University of Saskatchewan was not the original owner of the structure, it has always been located on university lands.

In 2013 the Seed Barn was moved to a location north of East Road (Figure 12). The Barn was moved in order to accommodate new development on its original site. Its original concrete ground floor walls had already been replaced once, and when the building was moved, it was placed on a new foundation.

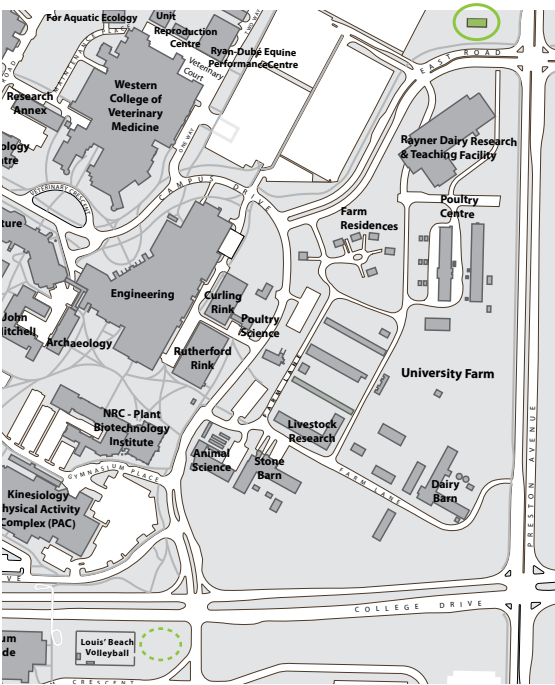
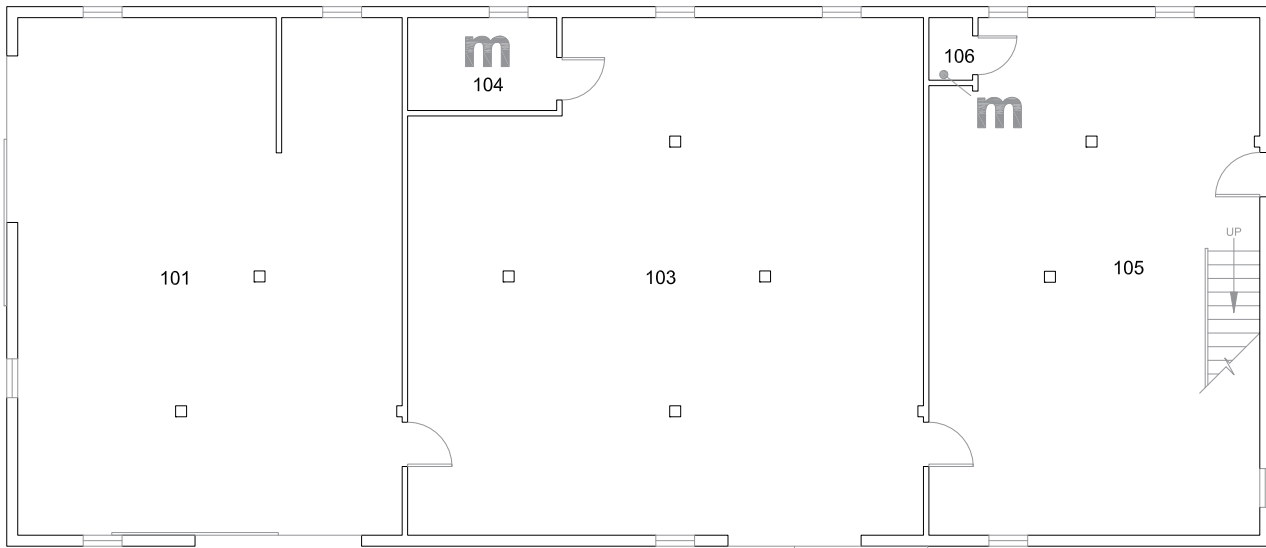
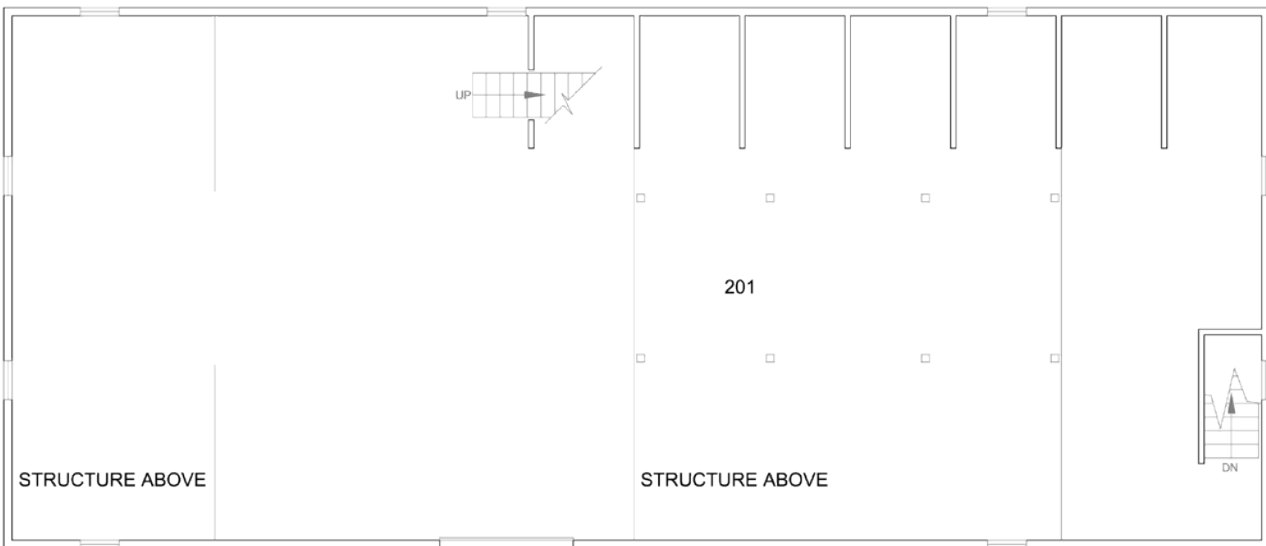

Figure 12. The current location of the Seed Barn is indicated in green and the former location is indicated by a dashed green circle on this contemporary campus map.



1st Floor



2nd Floor

Figure 13. The 2012 configuration of the first and second floors of the Crop Science Seed Barn. FMD asset record system.



Figure 14. Exposed roof trusses.

2.4 Spatial Configuration

The Seed Barn is configured as a standard livestock barn, with the animal stalls located on the ground floor and a hayloft on the second floor. The original floor plans either never existed or have been lost. The ground level appears to have been completely replaced at some point, so the current configuration of partitions is likely not original. The early photograph in Figure 8 shows a regular arrangement of windows on the ground floor, which likely matched the arrangement of stalls inside. Figure 13 shows the layout as of 2012, before the building was moved to its current location. The second floor hayloft is original and has good commemorative integrity. This high, open space with its dormer windows and exposed rafters is a character-defining element (Figure 14).

2.5 Systems

The Seed Barn is a wood framed building with a cast-in-place concrete foundation. The roof system consists of a framework of arched wooden trusses, which are supported by the exterior walls. The walls are built of 2" x 6" Douglas fir studs at 24" centres, with wood sheathing on both the interior and exterior surfaces. The loft floor structure consists of 2" x 10" wood joists on 24" centres with a subfloor of 1" x 6" wooden planks. The floor is supported by the exterior walls, and on the interior of the building by a heavy timber structure of Douglas fir posts and beams. The exterior walls sit on a concrete foundation wall raised about 12" above the finished surface of the floor. The construction of the foundations is unknown. The ground floor is a poured concrete slab on grade. The exposed wooden roof trusses and timber posts and beams are character-defining elements.

Several systems were incorporated into the building for the handling of hay and other storage. A large set of loft doors on the south side of the building allowed hay to be loaded directly from the exterior. Originally, as shown in the photograph in Figure 8,



Figure 15. Dovetailed column detail.

these doors were accessed from an earth ramp. Later, when the concrete ground floor walls were replaced, the ramp was removed, and a hoist system was added. The hoist arm is still in existence, and visible in Figure 9. Inside the loft, a rail and pulley system was installed to facilitate to movement of hay bales (Figure 16).

A red brick chimney was removed as part of the operation to move the building in 2013 (Figure 17).

2.6 Use(s)

The Seed Barn was originally owned by the Federal Government. In the 1950's, the University of Saskatchewan acquired the structure for use by the Department of Field Husbandry. The barn held horses, which were used as draft animals until the advent of the tractor. Later, the barn was used for seed storage and crop science research, hence its name. Since 1972, when a new seed storage facility was built, the Seed Barn has only seen ancillary uses such as storage and staging. Character-defining uses of the Seed Barn include agricultural research, education and the storage of livestock and grain. Figure 18 shows a class of Agriculture students inspecting a crop, with the Seed Barn visible in the distance.



Figure 16. Steel rail & pulley system attached to wood beam.

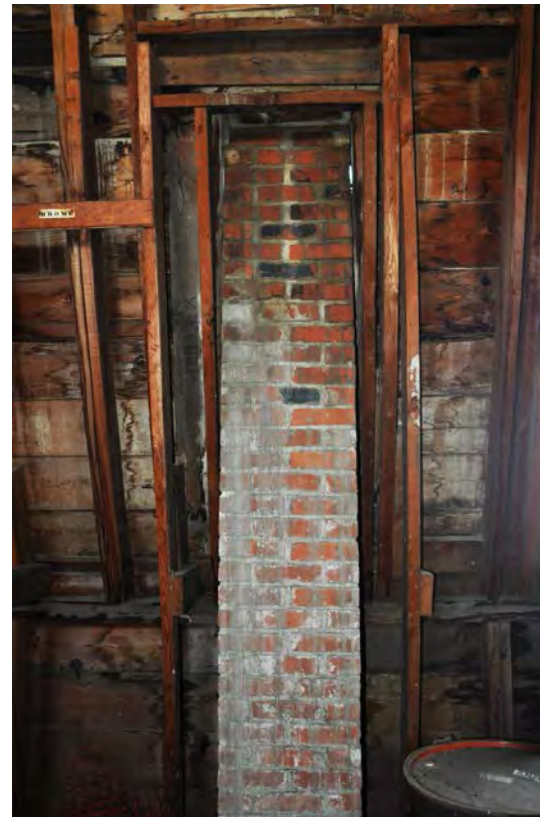

Figure 17. Chimney, now removed.



Figure 18. An agricultural degree class inspecting Arctic Clover, 1920. The Crop Science Seed Barn is visible in the background. Photo A-1825 retrieved from University of Saskatchewan Archives.

2.7 Cultural & Chronological Associations

The Seed Barn is associated the University Farm and agricultural education at the University of Saskatchewan.

3. Associated Objects

N/A

4. Supporting Documents

Bryan, H. Personal Communication. July 4, 2012.

Hartl, C. Personal Communication. September 5, 2013.

Scoles, G. Personal Communication. July 3, 2012.

University of Saskatchewan Archives, RGM 300.32, Misc. 1959
Appraisal of the University.

Hoffman, D. (2012, January 25) University hunts for childcare funding: USSU asked to endorse \$5 to \$10 per-term student fee increase. *The Sheaf*. Retrieved from <http://thesheaf.com/2012/01/25/university-hunts-for-childcare-funding-ussu-asked-to-endorse-5-to-10-per-term-student-fee-increase/>



5. Summary of Character - Defining Elements

Materials

- cedar shingles and siding
- painted wood-framed sash windows
- Douglas fir walls, posts and beams

Form & Style

- gambrel style roof
- scale
- barn
- exposed rafter ends
- dormer windows
- roof ventilators
- loft doors

Location

- University of Saskatchewan campus

Spatial Configuration

- two storeys
- ground floor animal stalls
- second floor hayloft

Systems

- wood-framed structure
- exposed wooden trusses
- Douglas fir post and beam structure
- hoist, rail & pulley systems

Uses

- horse barn
- seed storage
- crop research

Cultural & Chronological Associations

- College of Agriculture

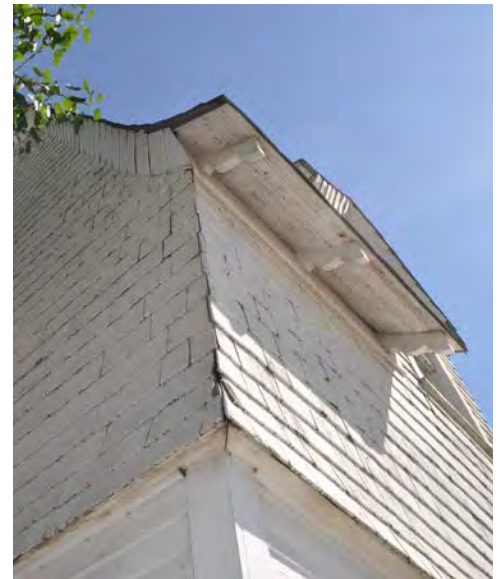

337

Stone Barn



337

Stone Barn

Alternate Names

Main Barn

Architect(s)

David R. Brown, and Hugh Vallance, Brown and Vallance Architects, Montreal

Builders

Alexander R. Greig

Construction Dates

1911-1912

Recognition

University of Saskatchewan 'A' Listed



Figure 1. Concrete silos with cedar shingle roofs.



Figure 2. Top to bottom: Asphalt roof shingles have replaced the original cedar shingles, carved exposed wooden truss ends. The cedar shakes on the upper portion of the main barn have been painted white.

1. Statement of Significance

The Stone Barn is a landmark building that serves as a symbol of the agricultural focus and history of the University of Saskatchewan. The barn reflects the importance of the College of Agriculture as a fully affiliated college within the university, a relationship that at the time defied Canada's tradition of separate agricultural colleges. The prominent location of the Stone Barn at the eastern edge of the campus makes it a marker for the University of Saskatchewan within the city. The Stone Barn originally served as a facility to house cattle and horses. The first Dean of Agriculture, William Rutherford, presided over the operation of the Stone Barn for many years before his death. The Stone Barn is therefore heavily associated with this individual who had a great influence on the development of agricultural education at the university and across Western Canada.



Figure 3. The Stone Barn, 1920. Photo A-11007, retrieved from University of Saskatchewan Archives.

Architecturally, the barn distinguishes itself from other university buildings, deviating from the Collegiate Gothic style that typifies the rest of the main campus. With its Gambrel roofs, roof ventilators, and dormer windows, the Stone Barn is in keeping with other North American dairy and livestock barns of the early twentieth century, although it is larger than most and its distinctive stone walls are unusual. Its two concrete silos are also likely the oldest in the province. Though still standing and retaining most of its architectural integrity, the Stone Barn is no longer functional. The building was closed in September 2010 due to the structural degradation of its stone pilasters.



Figure 4. Ground floor walls are constructed of red and grey, rough-faced granite. Windows are framed in wood.

2. Character - Defining Elements

2.1 Materials

Despite its name, the Stone Barn is predominantly a wooden building; both its structure and cladding are built of wooden materials. Only the ground floor walls are built of stone. The upper portion of the exterior walls is clad in cedar shingles. The roof was initially also finished in cedar shingles, but these have since been replaced by asphalt shingles. The roofs of the silos are still shingled in cedar (Figure 1). The roofs of the barn, cupolas and silos all feature ornamental exposed wooden rafter ends, which are well preserved and are shown in Figure 2.



Figure 5. A portion of the stone fence which has fallen down.



Figure 6. Interior walls clad in wooden planks.

Windows are framed in wood and are single-glazed (Figure 4). In some places there are storm windows. Some exterior window sills feature concrete that has been replaced. A majority of the windows have retained their original glass; however, most are heavily weathered and are in poor physical condition. In a few instances the windows have been replaced or have been boarded up.

The ground floor walls and piers are constructed of rough granite of varying shades of grey and red (Figure 4).^{*} A stone paddock wall in the same rough granite was added at some time after the construction of the barn. The condition of the paddock walls is poor in many places. Parts of the stone wall have crumbled and have been replaced by a more temporary fence. The stone piers on the barn are failing in several instances and were the immediate cause of the building's recent closure. The stone walls of the barn have fared somewhat better but require re-pointing. The stone retaining wall that supports the remaining ramp is in good condition and maintains its commemorative integrity. Concrete has been used to refinish the top of this ramp.

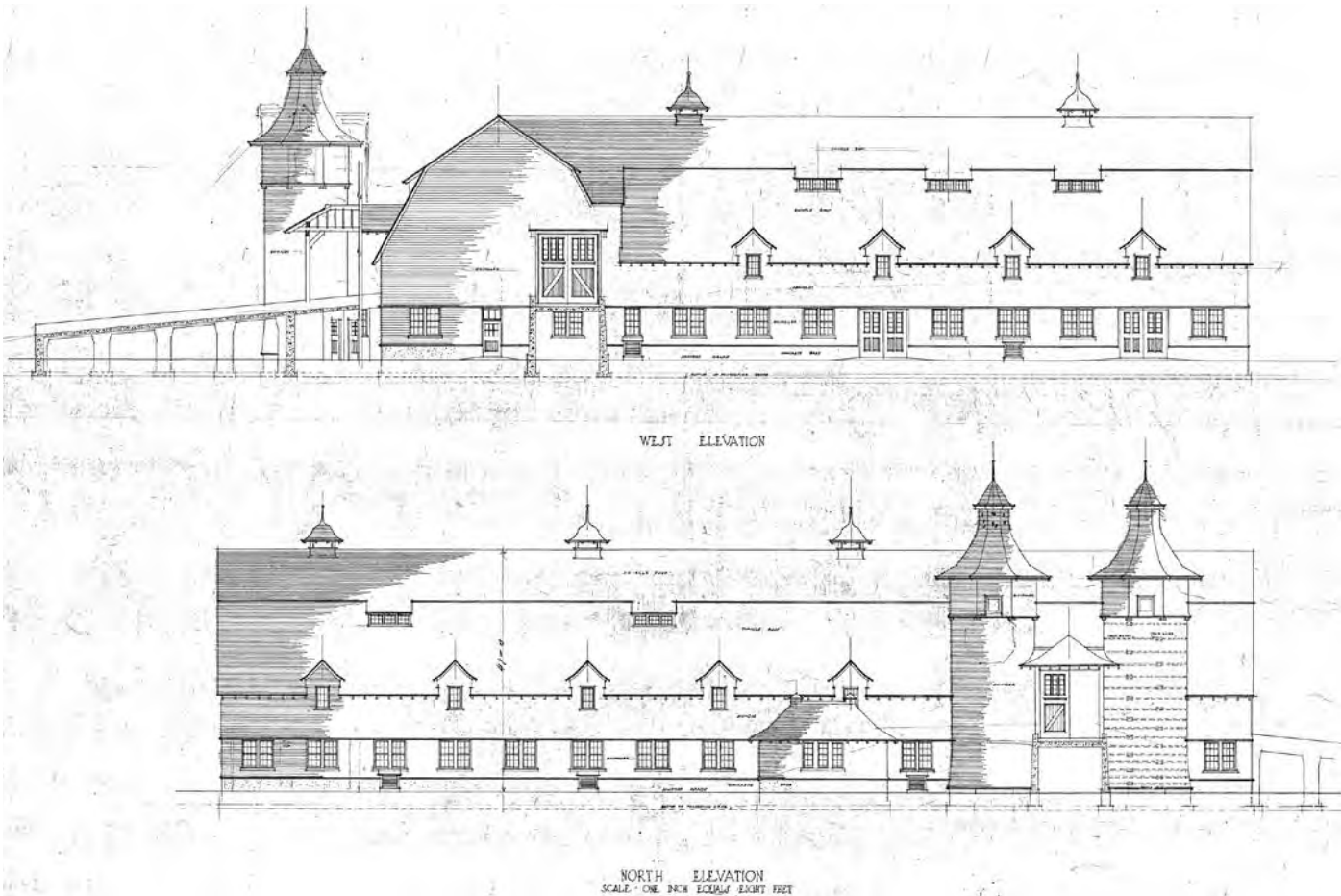

Figure 7. Elevations by Brown and Vallance Architects. In these drawings the lower walls of the barn are indicated to be wood rather than stone. The barn was not built exactly as shown. Retrieved from Facilities Management Division Asset Record system, File B-1-T.

On the interior of the building, the stone walls are clad with vertical wooden planking, painted white. Figure 6 shows this wooden sheathing covering the stone walls. Early elevations by Brown and Vallance Architects show that the building was originally conceived of as a wooden structure (Figure 7). The roof of the building is supported by a series of intricate trusses, made of Douglas fir. The trusses and decking are exposed and unpainted, and have been maintained to an excellent degree of commemorative integrity (Figure 8). These Douglas fir trusses and decking are important character-defining elements.



Figure 9. The interior of a silo constructed of concrete and Douglas fir

The silos are made out of cast-in-place concrete, with wooden roofs (Figure 9). Many of the original metal fixtures such as latches, hinges and pulley systems still exist in a good state of commemorative integrity. They are all either rusted or painted but remain functional.

The choice of material for the Stone Barn reveals the importance placed on agricultural education at the time. Service buildings at the university were generally constructed out of brick in its early years. Following this practice, the Livestock Pavilion was constructed of brick, as was the Power House. The high-quality materials of the Stone Barn reflect the importance of agricultural education to the University of Saskatchewan.

*For further information on building stones used at the U of S, refer to [‘Appendix: Stone’](#).

2.2 Form & Style

The plan of the Stone Barn is in the shape of an ‘L’ (Figure 15). There is an east and a west wing, the former measuring 160 feet by 48 feet and the latter 176 feet by 48 feet. The Stone Barn’s roofline is 44 feet from the ground and the building measures an even 50 feet high when the ventilation cupolas are taken into account. The ground floor area is 19,000 square feet. This is matched by the second storey hay loft. Two cylindrical concrete silos adjoin the building. The form of the Stone Barn maintains a great degree of integrity except for the removal of one of the large ramps; the barn used to have two ramps, however one was removed in order to make room for parking. Figure 3 pictures the Stone Barn in its original form with both ramps intact.



Figure 8. The loft features unfinished Douglas fir. The lower right corner shows a ventilation shaft that has been disconnected from a cupola. The opening for the cupola can be seen at the top left of the photograph.

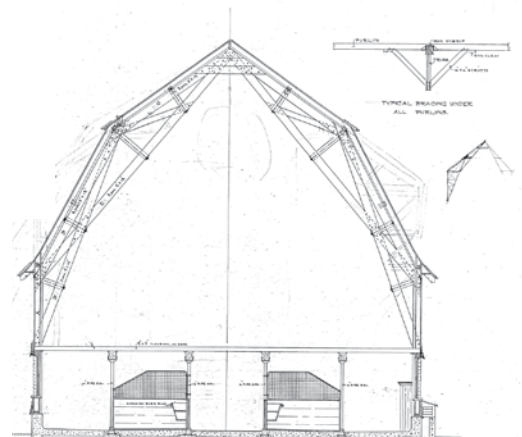

Figure 10. The Stone Barn’s Gambrel style roof. Retrieved from Facilities Management Division Asset Record System, File B-1-T.

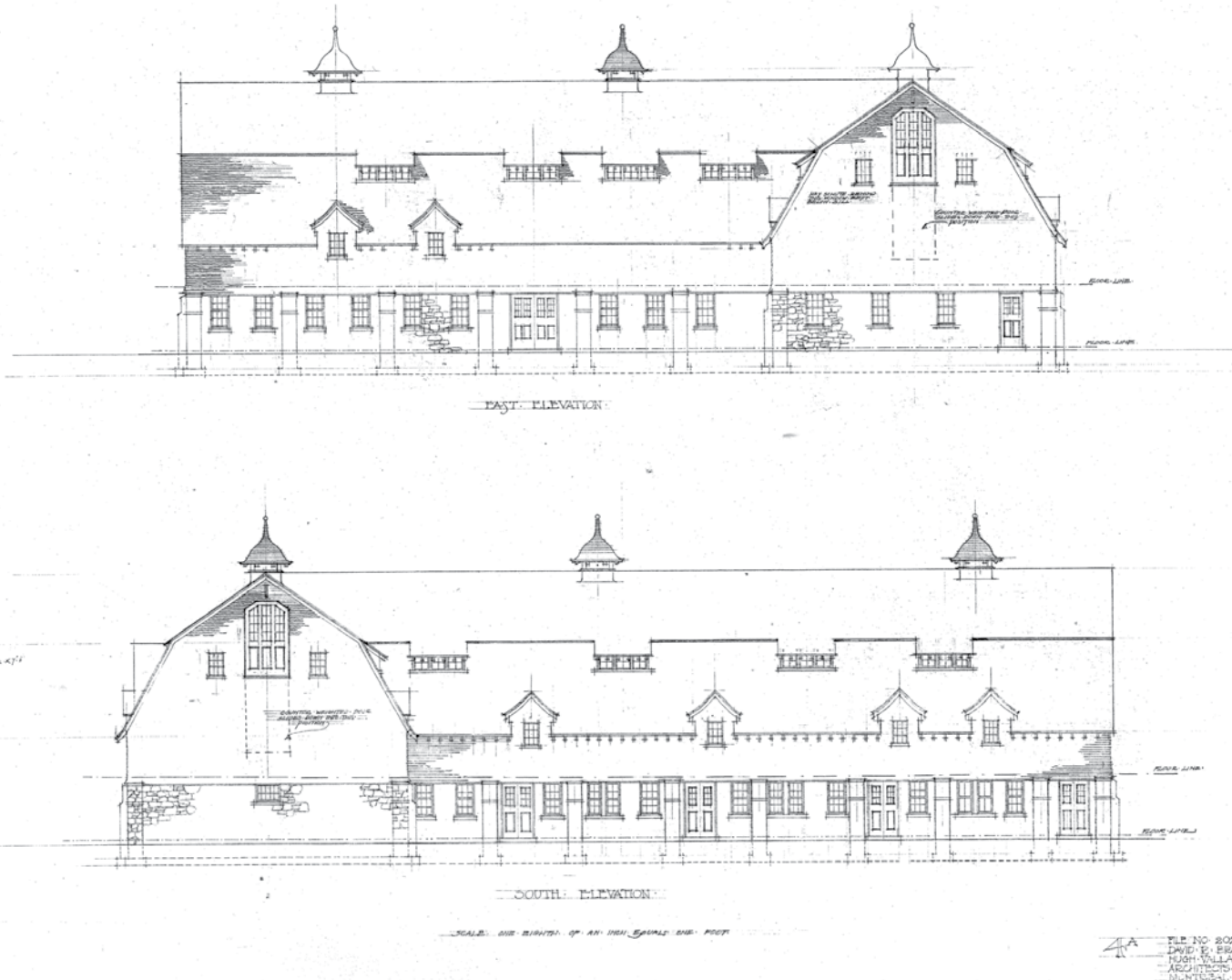

Figure 11. South and East elevations of the Stone Barn, by Brown and Vallance Architects. Here the lower walls are rendered as they were built, in stone. Note that the barn was not built exactly as shown. Retrieved from Facilities Management Division Asset Record System, File B-7-T.

The Stone Barn is different in style, form and material from other University of Saskatchewan buildings of its time. Rather than the limestone walls and characteristic forms of the Collegiate Gothic, the barn features a Gambrel style roof, and is built of wood and granite. In style, the Stone Barn is typical of North American dairy and livestock barns of the early twentieth century, although it is larger than most, and built to a very high standard of construction. Gambrel roofs, roof ventilators and dormers, and multiple windows are the distinctive features of this style of barn, which became popular in the United States and Canada around 1850. The Gambrel roof has a shallow slope near the peak of the roof and a steeper pitch near the eaves (Figure 10). This shape provides the Gambrel roof with more space in the loft. The roof is meant to overhang the walls.

The roof of the barn is topped by a series of prominent wooden cupolas that function to provide ventilation. On the interior, these cupolas are connected to wooden shafts that are designed to produce a stack effect and exhaust stale air from the building. These shafts reach from the centre of the roof to the floor on either side of the barn. The amount of ventilation could be controlled by opening and closing doors located on the sides of the wooden shafts. The majority of these ventilating systems are intact, although some of the cupolas have been disconnected from their shafts. Figure 8 shows one such disconnected shaft.

The Stone Barn features two very distinctive concrete silos with ornate steepled roofs (Figure 11). The gambrel style roof of the Stone Barn, its roof ventilators, dormer windows and silos are all character-defining elements.

2.3 Location

The Stone Barn is located outside of the pedestrian area of [‘The Bowl’](#), but its location gives it prominence nonetheless. Currently the barn is perhaps the most visible structure from outside the university. Located alongside College Drive, the Stone Barn’s height and size draw attention from pedestrians and motorists. The pasture to the south of the barn serves to frame the agricultural scene. Figure 14 illustrates the prominence of the barn to passersby on College Drive. The Stone Barn is a marker that serves to herald the presence of the University of Saskatchewan.



Figure 12. Carved wooden brackets flank the ramp doorway and carved wooden rafter extensions are visible under the eaves.



Figure 13. Cupola and dormer window.

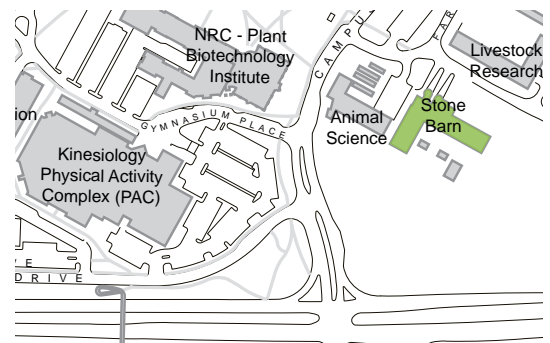

Figure 14. The Stone Barn is located immediately north of College Drive.

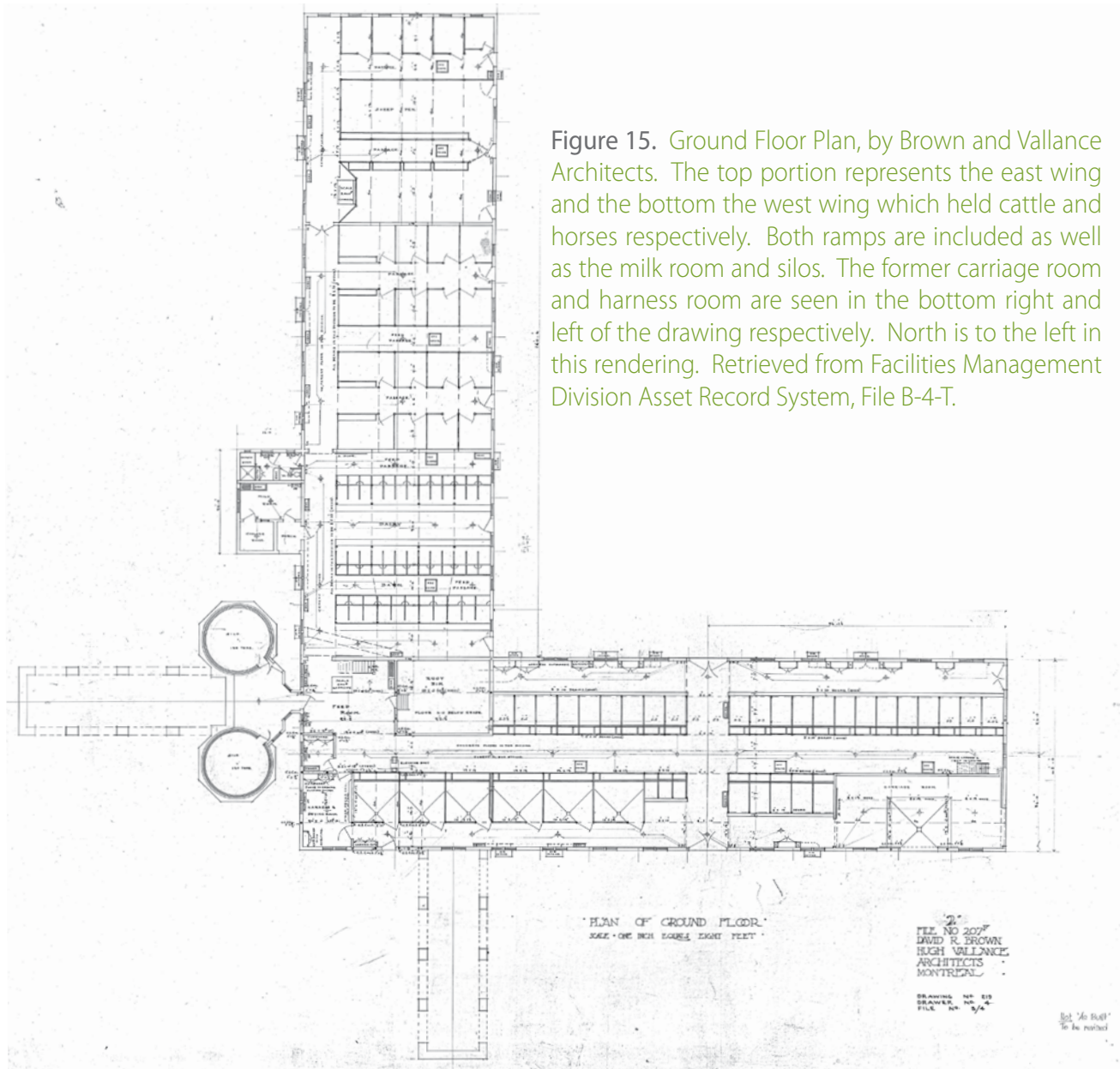

Figure 15. Ground Floor Plan, by Brown and Vallance Architects. The top portion represents the east wing and the bottom the west wing which held cattle and horses respectively. Both ramps are included as well as the milk room and silos. The former carriage room and harness room are seen in the bottom right and left of the drawing respectively. North is to the left in this rendering. Retrieved from Facilities Management Division Asset Record System, File B-4-T.



Figure 16. Interior of the horse corridor ca. 1920 with mangers on either side. The photo demonstrates how tightly configured the building was before the stalls were removed. Photo A-72, retrieved from http://scaa.sk.ca/gallery/uofs_buildings/

2.4 Spatial Configuration

As a working agricultural building, the spatial configuration of the Stone Barn has necessarily changed over time. Figures 15 and 16 show how the ground floor was originally divided into livestock stalls. Originally, the west wing was configured for equestrian use and the east for cattle and sheep. Figure 16 is a view of the west wing when the stalls and feeders were in place. All of these stalls have since been removed, leaving the area a completely open space. The existing layout of the ground floor is therefore in a poor state of commemorative integrity.

Originally, a 22 foot by 40 foot carriage room, visible in Figure 15, was located in the southwest corner of the west wing. When horse-drawn carriages went out of use the carriage room was removed. The northwest corner of the east wing was set aside as a room for harnesses and horse accessories. In addition to this, approximately 10 harness cupboards were installed on the east and west walls of this wing. Adjacent to the harness room there was originally a staircase with access to the loft. All of these features have been removed. A large feeder stands where the harness room used to be. A heavy wooden door with an iron latch are all that remain of this room.

The hay loft is a remarkable, cathedral-like space; soaring to a height of about 35 feet and supported by a series of intricate wooden trusses. The hay loft is accessible from both a staircase inside the building and from an exterior ramp on the north side of the building (Figure 17). Another ramp on the west side, visible in Figure 3, has been removed.

2.5 Systems

In 2010, a structural analysis of the Stone barn was carried out, which determined that degradation of the stone piers had reached a critical state. As a result, the Stone Barn was closed in September 2010. The failing structure of the Stone Barn is obviously a threat to its heritage value.

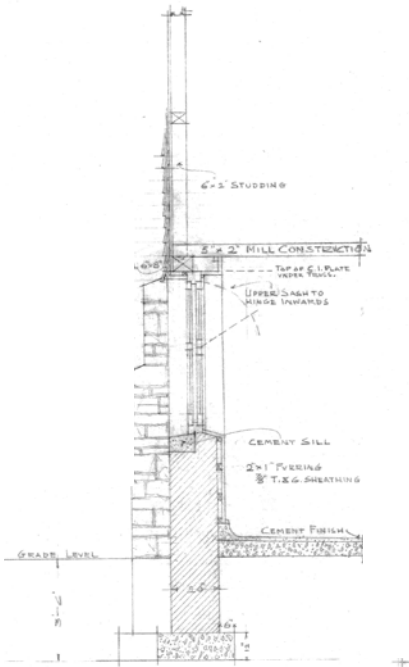

Figure 20. A wall section by Brown and Vallance Architects: Stone pilasters thicken towards the base.

The roof of the building is composed of Douglas Fir decking, supported by a series of intricate Gambrel style bolted girder trusses, also made of Douglas Fir, shown in Figures 18 and 19. The trusses span the full width of the building, and are supported by the exterior load-bearing stone walls and pilasters. The exterior walls of the Stone Barn are constructed of granite. Stone pilasters, which thicken as they reach the ground, pick up the roof trusses (Figure 20). Figure 21 illustrates the deterioration of the stone walls.

The loft floor is composed



Figure 17. The remaining ramp.



Figure 18. The structure of the barn roof.

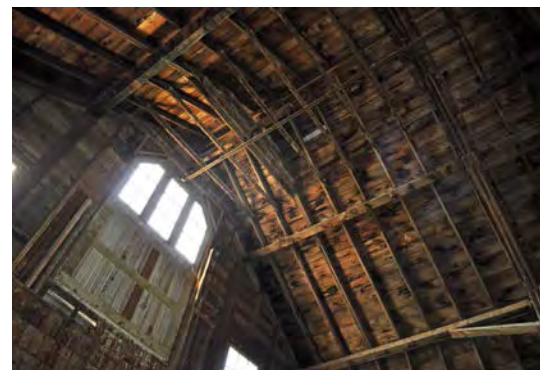

Figure 19. An elevated door at the end of the loft intended to receive hay.



Figure 21. Deterioration of the walls of the Stone Barn.

of 2" x 5" fir planks laid on edge. This floor is supported by the exterior walls, as well as by two 10" x 16" fir beams running the length of the building, which are in turn supported by steel posts (Figure 23.) In the west wing, two wooden posts can also be found.

The structural systems of the Stone Barn are original, and with the exception of the exterior stone walls and pilasters, exist in an excellent state of commemorative integrity. They are a large contributor to the aesthetic value of the space, and are important character-defining elements.

The Stone Barn also features a noteworthy system for circulating feed. A steel rail runs along the roof line of the loft and extends outside either end. Figure 24 pictures the rail system extending out from the wall above the loft door. Figure 25 shows the curving rail drawn to serve the whole loft space. At the end of each wing of the building, a loft door still exists. With hooks and pulleys, bales and feed could be hoisted from the ground outside into the hay loft, and from there could be transported around the building and lowered to the ground floor through trap doors in the loft floor. Most of the trap doors have been fastened shut or covered over with wood. Figure 26 illustrates a trap door that has not been decommissioned. The rail system remains in an excellent state of commemorative integrity.

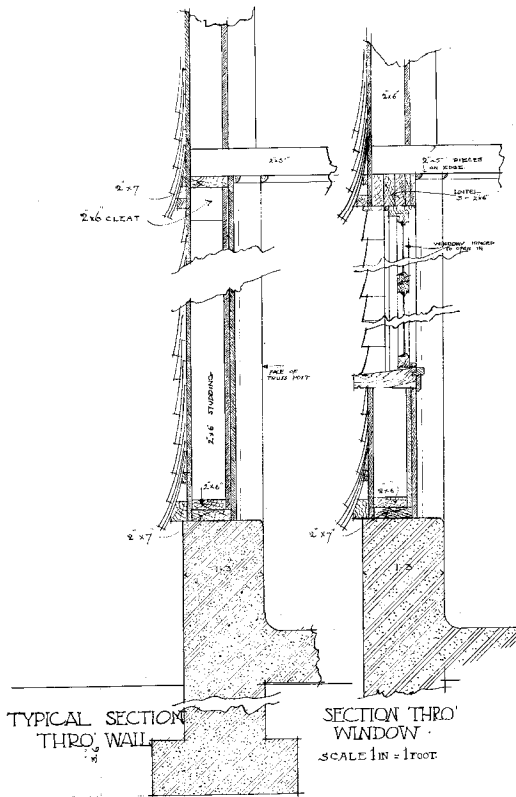

Figure 22. Early wall sections by Brown and Vallance architects showing a wall structure of 2x6 studs rather than load bearing stone.

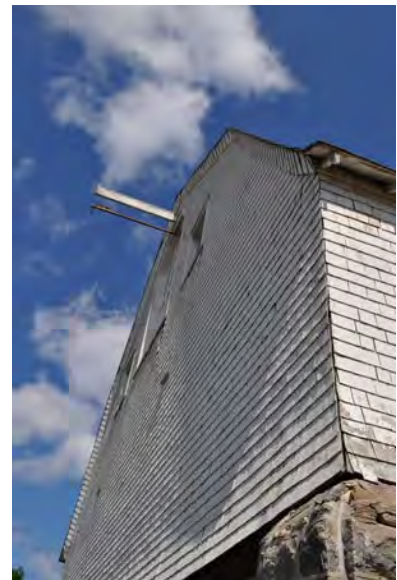

Figure 24. The loft trolley system extends from the barn.



Figure 23. Steel posts support wooden beams.

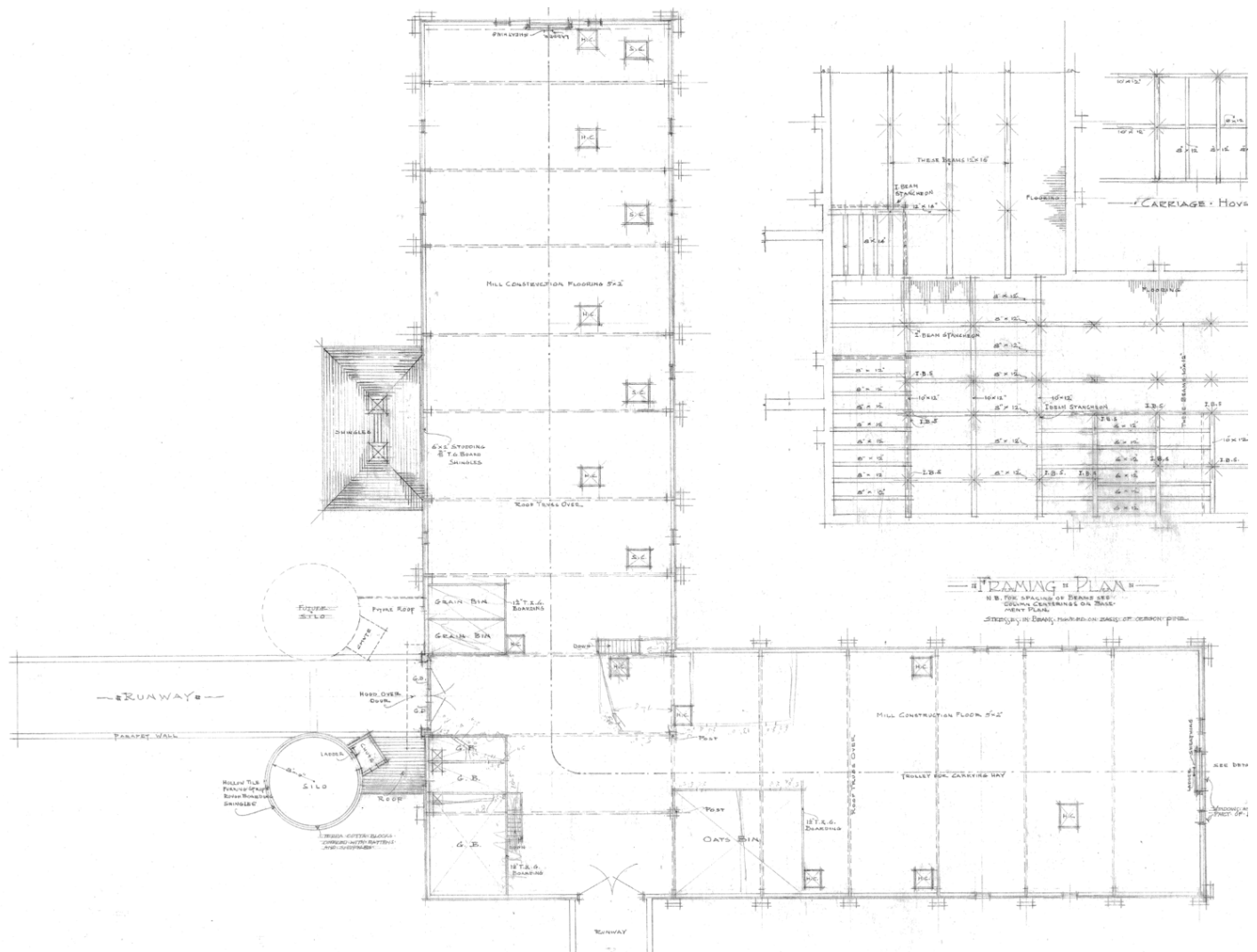

Figure 25. A plan view of the loft. Retrieved from Facilities Management Division Asset Record System, File B-8-T.

2.6 Use(s)

The Stone Barn was built to house 50 head of cattle and 30 horses in the east and west wings respectively. The entire loft was set aside for hay storage. The barn housed different sized stalls for younger animals, maternity animals, bulls, stallions and milking stations. A milk room and carriage room as well as a room for storing harnesses served the primary functions of the building. Horses were housed in the building up until the early 1950's. The horses were used to tend to the crops of the University Farm until they were replaced by tractors. Figure 27 shows the horses being readied for use in the field, before the era of tractors. The University of Saskatchewan was one of the last agricultural colleges to eliminate its equine stock. Besides housing animals, the Stone Barn served the many



Figure 26. A trap door in the loft opens into an aisle below.



Figure 27. A photo from the 1920's shows teams and teamsters outside the Stone Barn ready for a day's work. Photo A-69, retrieved from University of Saskatchewan Archives.



Figure 28. Sheep shearing time at the University of Saskatchewan. Photo retrieved from Bell, M.J., (1996) *Hoofprints to Reprints: The History of Animal Husbandry, Animal Science and Animal and Poultry Science, University of Saskatchewan 1909-1989*.

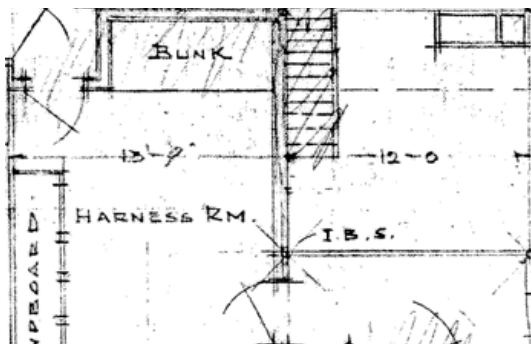

Figure 29. A bunk drawn into original floor plans. Retrieved from Facilities Management Division Asst Record system, File B-9-T.

functions that go along with livestock husbandry and research. Cows were milked, animals bred, sheep sheared (Figure 28), research and experimentation carried out. In its first decades, the Stone Barn housed several champion Clydesdale horses bred by first Dean of Agriculture, William Rutherford. Award winning cattle were raised in the barn.

The inclusion of bunks in the building plans shown in Figure 29 reveals that the building was not only a home for livestock but perhaps for people as well. Farm hands may have originally spent nights here in order to keep vigil over the animals in their care. This practice changed over time and no living quarters remain. Currently, the Stone Barn is in a state of disuse.

2.7 Cultural & Chronological Associations

The Stone Barn has a character-defining element in its cultural association with the first Dean of Agriculture at the University of Saskatchewan, William Rutherford. Rutherford was Dean of the College until his death in 1930 and was recognized as the founder of agrarian education in Western Canada. He was posthumously inducted into Saskatchewan's Hall of Fame.

The heavy concrete silos of the Stone Barn are considered to be the oldest structures of their kind in Saskatchewan. The structures therefore possess significant heritage value and are an integral character-defining element of the Stone Barn.

This building has an obvious association with agriculture. The Stone Barn expresses its association with livestock not only in its historical use, but in its form and style. The University of Saskatchewan was the first university in Canada to fully incorporate a College of Agriculture, and this aspect of its history is most prominently commemorated in the Stone Barn. The Stone Barn serves as a monument to the proud history of agricultural education at the University of Saskatchewan, marking the affiliation of the university with the agrarian culture that is innate to Saskatchewan.

3. Associated Objects

N/A

4. Supporting Documents

Bell, M.J. (1996). *Hoofprints to Reprints: The History of Animal Husbandry, Animal science and Animal and Poultry Science, University of Saskatchewan 1909-1989*. Saskatoon: University of Saskatchewan.

Facilities Management Division (2011). Asset Record System [Data File]. Retrieved from <\\usask\fmddfs\files\iis\IISPublic\ARS>

Genivar Inc. (2011). Stone Barn Structural Investigations and Recommendations. Retrieved from Facilities Management Division.

Hanson, S. (2000). *Dictionary of Canadian Biography Online: Rutherford, William John*. Retrieved from http://www.biographi.ca/009004-119.01-e.php?&id_nbr=7963&&P_HPSESSID=yhzfqkvzape

University of Saskatchewan Archives. (Retrieved 2011). *Main Barn*. Retrieved from <http://scaa.sk.ca/gallery/uofs/buildings/>





5. Summary of Character - Defining Elements

Materials

- cedar shingles
- douglas fir structural elements
- wood-framed windows
- granite walls and piers
- concrete silos
- metal fixtures

Form & Style

- gambrel style roof
- cupolas
- steeple roofs
- carved truss extensions
- dormer windows

Location

- visibility as university landmark
- part of university 'farmstead'

Spatial Configuration

- ramp
- interior loft

Structural Systems

- granite pilasters
- loft floor - 2x5's laid on edge
- fir beams
- gambrel style bolted girder trusses
- feed circulation system - trolley rail and trap doors

Uses

- livestock breeding
- livestock research and experimentation
- milking cows and shearing sheep

Cultural & Chronological Associations

- Dean William Rutherford
- silos - considered to be oldest in Saskatchewan
- agriculture at the University of Saskatchewan

346

Feed Elevator



346

Feed Elevator

Alternate Names

**Grain Elevator
Elevator**

Designer

Saskatchewan Wheat Pool

Builder

Saskatchewan Wheat Pool

Construction Dates

1951

Recognition

University of Saskatchewan 'B' Listed

1. Statement of Significance

The University of Saskatchewan Feed Elevator was designed and built in 1951, by the Saskatchewan Wheat Pool, for a budget of \$25,000. The Feed Elevator was used for grain storage by the university farm as well as for weighing, mixing, grinding and cleaning grain. In the 1970's, an annex was added to the west side of the building. The building went out of use in the mid to late 1990's, when all of the resources of the College of Agriculture were focused on the construction of the new Agriculture Building.

The Feed Elevator is a relatively unaltered and classic example of a prairie grain elevator. The Elevator contains heritage value in its form, materiality and configuration, typical of the standard type of elevator built on the prairies in the first half of the twentieth century. This heritage value is threatened by the elevator's current state of maintenance and repair. Its commemorative value is at risk due to infestation by pigeons and other vermin, the resulting accumulation of guano and staining of its interior materials.



Figure 1. Aluminum cladding, cedar shingles.



Figure 2. Wooden window frame.



Figure 3. Cribbed cedar wall.

2. Character - Defining Elements

2.1 Materials

The Feed Elevator is a wooden structure, clad in shingled aluminum tiles (Figure 1). The cladding is in good commemorative condition. Metal cladding is characteristic of grain elevators, having come into use just before the First World War. The elevator has painted wood doors and single-glazed wood framed sash windows, both of which are in poor condition (Figure 2). The roofs are clad in cedar shingles, which are also in poor condition (Figure 1). All of the original exterior materials – aluminum tiles, wood doors and windows and cedar roofing shingles – are character-defining elements.

The interior of the elevator is constructed predominantly of cedar. The cedar walls require cleaning, but are otherwise generally in good condition. The floors of the elevator are also wooden; however, the species of wood is indiscernible due to the condition of the floors. Other materials found on both the interior and exterior include steel which was used in the manufacture of much of the grain processing equipment inside the elevator.

2.2 Form & Style

The Feed Elevator took its iconic form from earlier precedents already common on the prairies. The prevalence, size and formal simplicity of the grain elevator on the flat Saskatchewan landscape have made it an iconic prairie structure, highly visible and easily identified. In small Saskatchewan communities, the name of the town was often painted in block letters on the side of its grain elevator, along with the name of the elevator operator. For this reason, and the fact that the elevator was usually a town's tallest structure, the grain elevator was a landmark in most prairie farming communities. The university's Feed Elevator is about 23 metres tall, and at one time had the same high visibility as its rural counterparts (Figure 4). The words 'University of Saskatchewan' are painted prominently on its side.

The form of the Feed Elevator is a character-defining element as it is typical the standard Saskatchewan elevator, a type also known as a 'Primary Elevator'. The basic form of the primary elevator type is similar to that of a basilica – a gabled tower, with lower shed structures appended either side. Figure 5 shows the current form of the elevator.



Figure 4. Feed elevator, 1956. Photo A-95, retrieved from <http://sain.scaa.sk.ca/items/index.php/university-of-saskatchewan-archives;jsdiah>



Figure 5. The Feed Elevator in its current form. 'University of Saskatchewan' is printed on its east side in block letters. Retrieved from <http://www.waymarking.com/gallery/default.aspx?f=1&guid=cb8977bd-d531-46e3-940f-863672e815e3&gid=2>

The term ‘Primary Elevator’ distinguishes grain elevators located in smaller farming communities from the larger ‘Terminal Elevators,’ built in terminal cities like Vancouver and Thunder Bay, where grain was collected and stored before being transferred to ships. Primary elevators received grain directly from farmers. The shape and height of the primary elevator derived from its function, which was to store grain and load it onto railway cars. As utilitarian agricultural structures, they were built without much regard for ornament or architectural style. Grain was received from farm trucks in a ‘drive shed’ and dumped into the ‘front pit.’ From the front pit, a conveyor system called a ‘leg,’ which consisted of a long belt with grain cups, would lift the grain to the top of the elevator. There, grain was channeled by a ‘distributor’ (also known by the trade name ‘Gerber’) into one of several vertical bins for storage. Loading onto a railway car occurred by gravity feed, through the ‘loading spout.’ The tower portion of the elevator enclosed the leg and grain storage bins. Secondary functions like motors and weigh scales were enclosed in lean-to structures off the side of the central, vertical volume. The university’s Feed Elevator has all of these elements except for the loading spout, since it was not used to load railcars. However, it does have a drive shed and engine room built in the form of a lean-to, in keeping with the typology (Figure 6).

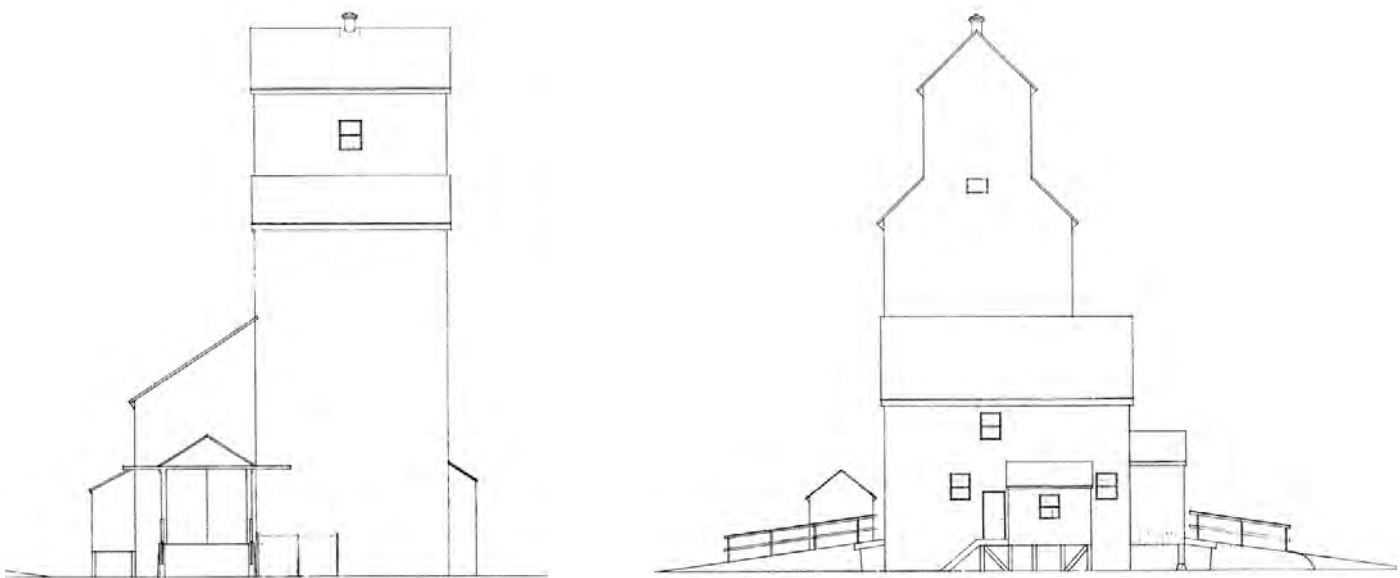

Figure 6. L to R: North and East elevations of the Feed Elevator. Retrieved from Facilities Management Division Asset Record System, File GE-7-T.

In 1913, standards for elevator construction were adopted by the Canadian Pacific Railway, which made for uniformity in the design of elevators for the next 50 years. In order to receive a license to operate along the CPR tracks, an elevator had to have a minimum capacity of 25,000 bushels. The typical capacity was 35,000 bushels, which required dimensions of 31 feet by 33 feet. The university's elevator has a slightly lower capacity of 21,300 bushels and its footprint is correspondingly smaller at 28 feet by 28 feet. The apex of the elevator is approximately 75 feet above ground. The Feed Elevator had an annex added to its west side in the 1970's as illustrated in Figure 7. Additions were common to elevators whose capacities were being exceeded. The addition is beyond the scope of this report.

The height, form and stylistic simplicity of the Feed Elevator are all character-defining elements.

2.3 Location

The location of an elevator on the University of Saskatchewan campus is unusual. Most prairie grain elevators were part of a larger grain distribution network, linking farms across the wheat belt to the national railway system. Elevators were typically located 13 to 16 kilometers apart, providing local access for all farmers to the transportation system. Elevators were built along the railway lines, since they were designed to transfer grain from the back of a wagon or truck to a railcar. The university's elevator did not form part of this system, and was built purely for feed storage; the grain was used to feed the university's livestock. The Feed Elevator is a rare example of a grain elevator whose location was not determined by access to the railway network. The location of the Feed Elevator is shown in Figure 8.

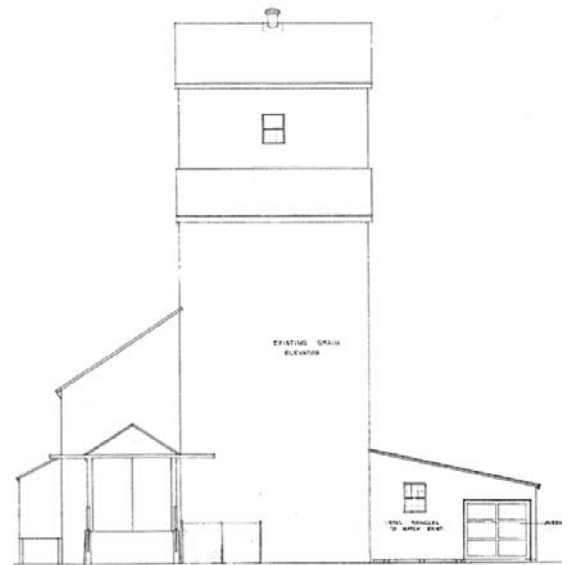

Figure 7. North Elevation of the Feed Elevator with addition. Retrieved from Facilities Management Division Asset Record System, File GE-12-T.

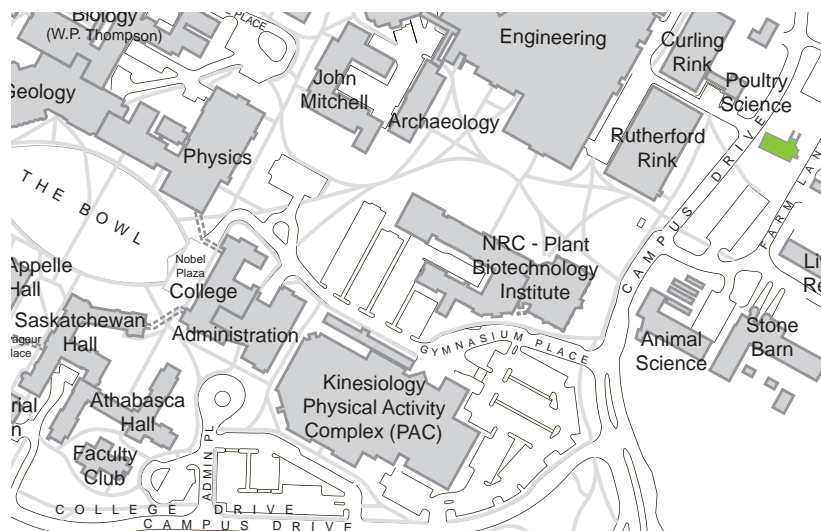

Figure 8. The location of the Feed Elevator is indicated in green on this contemporary campus map.

2.4 Spatial Configuration

The primary elevator typically consisted of three main functional components: a granary, a drive shed and an office. The university's Feed Elevator has all of these standard elements.

The granary is located in the tower portion of the building, and consists of elevated storage bins in the form of 18 vertical shafts. The plan layout of the storage bins inside the university Feed Elevator is shown in Figure 9, and they are shown in section in Figure 10.

The drive shed, or scale shed, was typically a lean-to structure. It had two openings to permit a wagon or truck to drive through. Trucks were weighed before and after unloading on a scale located in this space, to determine the quantity of grain delivered. The drive shed of the Feed Elevator is shown in Figure 11.

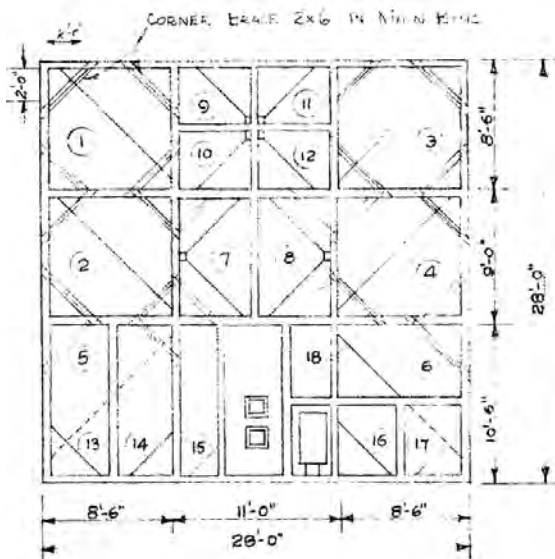

Figure 9. Plan of the grain bins. Retrieved from Facilities Management Division Asset Record System, File GE-1-T.

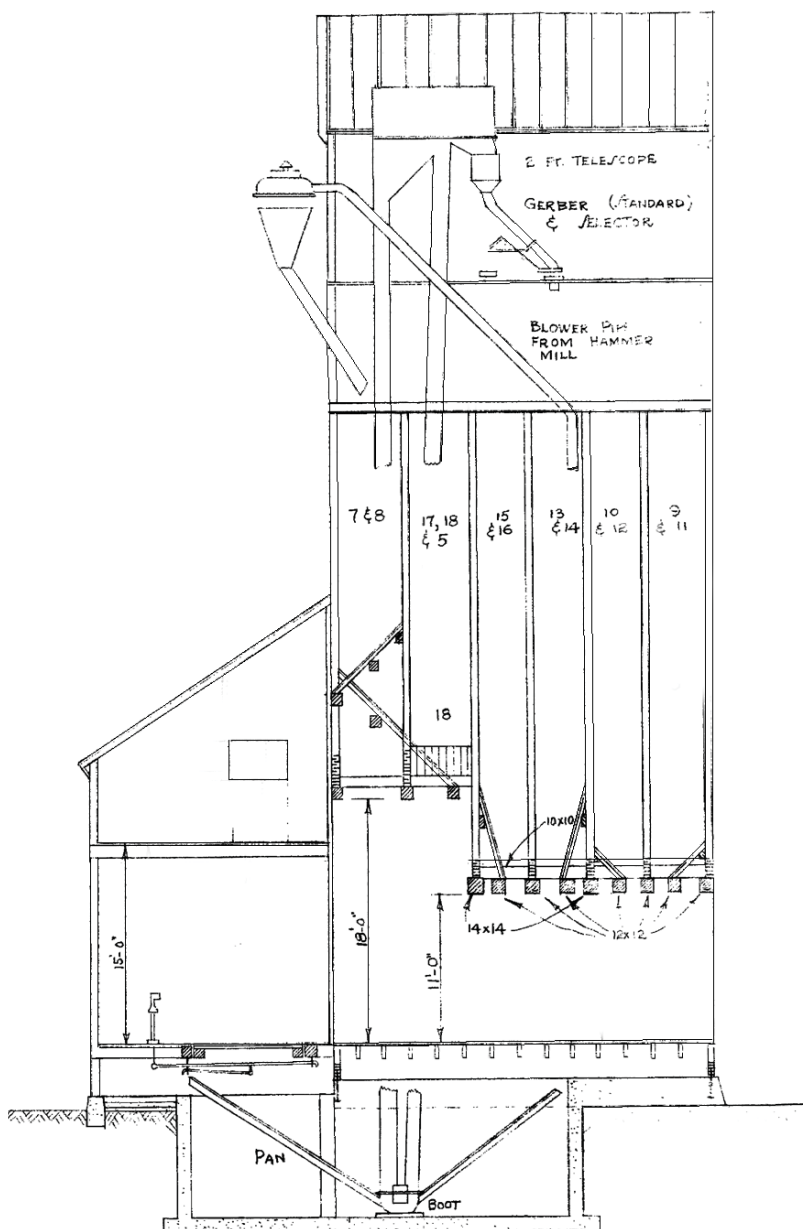

Figure 10. A section through the Feed Elevator. Retrieved from Facilities Management Division Asset Record System, File GE-5-T.

The Feed Elevator also has the standard office/engine shed appended to its east side in the form of a lean-to. Early elevators (pre-1920) featured an engine room with an office located above. With the advent of safer engines, the office and engine room were moved to the same level. As no room exists above the office in the Feed Elevator, it is presumed that it was configured in the latter fashion. Figure 12 shows the configuration of the work floor, including the drive shed. The office is not shown as part of the work floor but is depicted in the elevations provided in Figure 6.



Figure 11. Ramp and doors to the drive shed.

The Feed Elevator has a second floor accessible by a set of stairs in the drive shed. Some of the bins are accessible from the second floor where mixing took place.

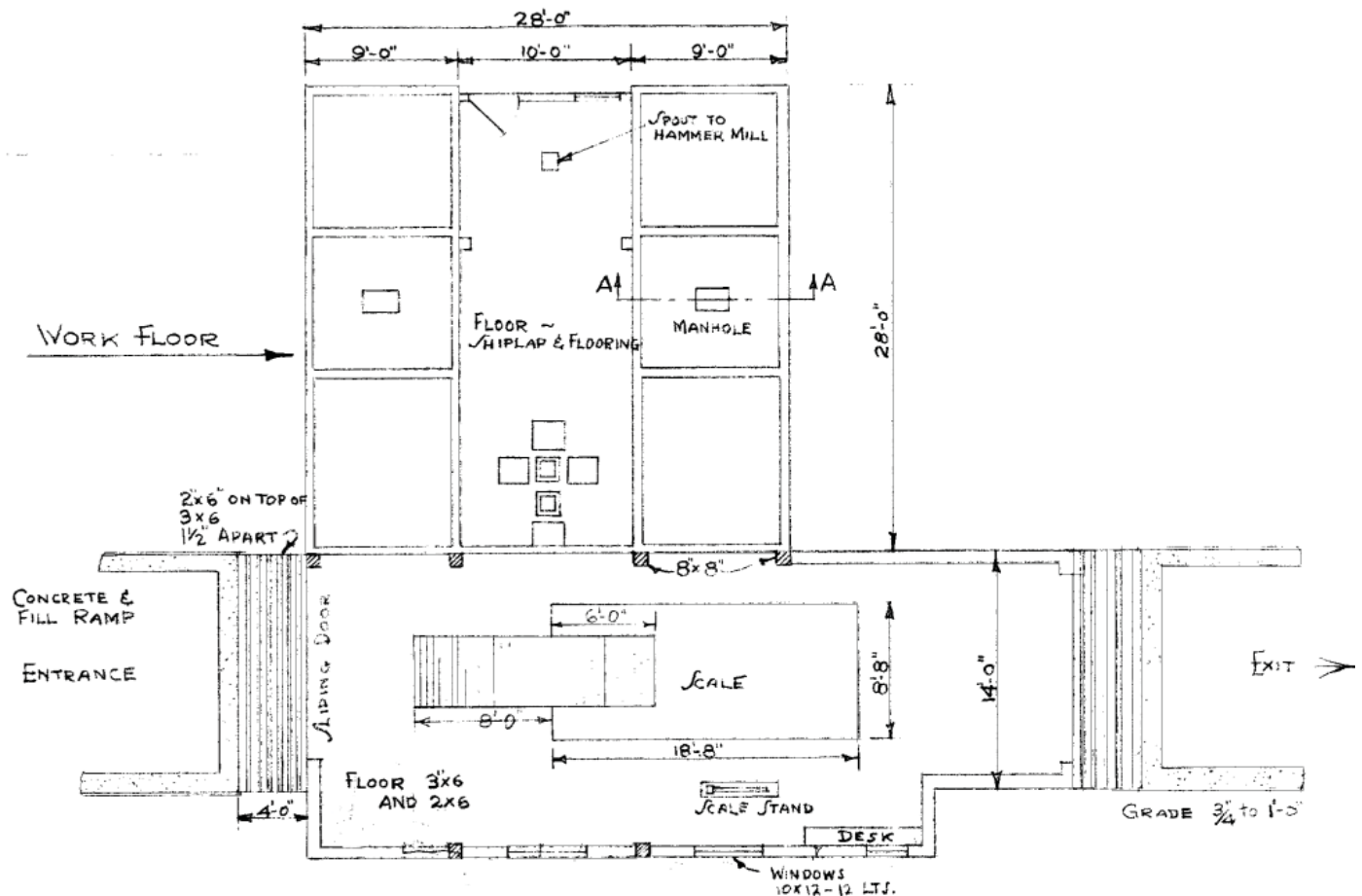

Figure 12. Original floor plan of the 'work floor.' The office and engine room are not included. Retrieved from Facilities Management Division Asset Record System, File GE-1-T.



Figure 13. Crank controlling delivery of grain to bins.

2.5 Systems

The primary elevator consisted of a series of simple systems designed to lift grain, store it and transfer it from truck or wagon to rail car. With the exception of the system to load rail cars, these components are all present in the university Feed Elevator, and are described above in Section 2.2 Form & Style. The drive shed in the Feed Elevator contains a scale on which trucks were weighed with and without their cargo. The difference in weight was used to determine the amount of grain the truck had delivered. The scale is still in place and is a character-defining element. Figure 11 shows the location of the scale stand and the scale in the drive shed.

Another character-defining element is a crank that appears to have controlled the distributor (Figure 13). A self-propelled elevator operated by pulley is also still in existence on the ground floor and is a character-defining element. This makeshift elevator provided the only means by which the top of the elevator could be reached.

The existence and state of commemorative integrity of the internal systems such as the leg, or grain belt, the pan below the drive shed and the 'spouts' which delivered grain to the bins is unknown. Figure 10 shows the design of the grain delivery system including the pan, grain belt, bins and spouts.

The structure of the Feed Elevator is a character-defining element with heritage value. All elevators had to be built to withstand tremendous pressure. In order to meet these criteria their walls had to be extremely strong. The construction of the elevator is exposed to view on the interior of the building. The interior walls and the walls of the grain bins are built of cribbed cedar 2x4's – that is, 2x4 laid up flat on top of each other and spiked together (Figure 3). Cribbed walls were a standard form of construction in prairie elevators and so their presence in the Feed Elevator is character-defining. Parts of the building are supported by heavy timber elements. The roof is built with 2 x 4 rafters at 24" centres and the exterior walls are constructed of 2 x 6 cedar studs at 24" centres. The cribbed construction of the Feed Elevator is a character-defining element, as this type of construction was used in most elevators. The cribbed cedar construction appears to be in good commemorative condition. (See also Section 2.1 Materials).

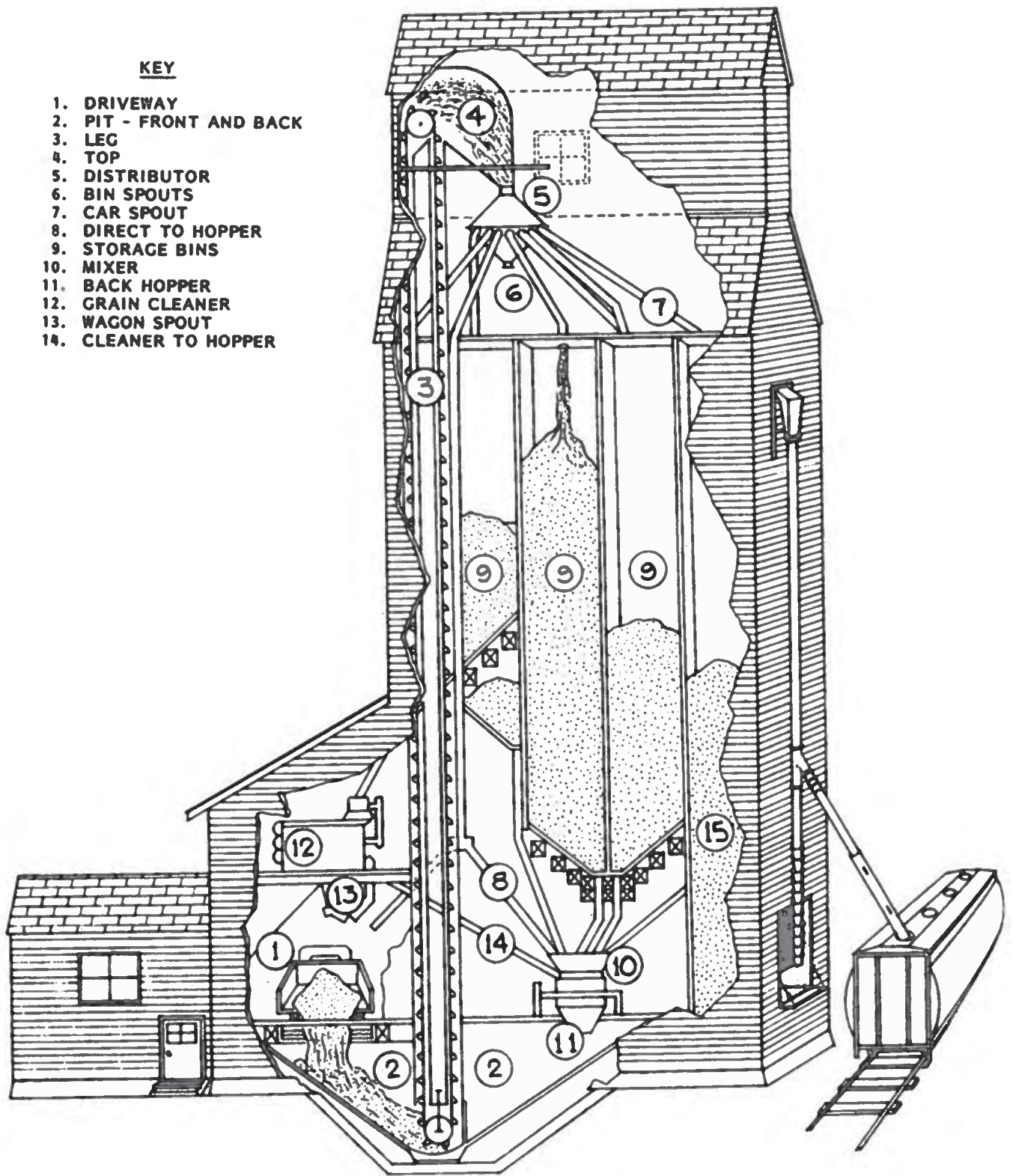

Figure 14. An annotated diagram of the operation of a typical grain elevator. Retrieved from Silversides, B.V., (1997) *Prairie Sentinel: The Story of the Canadian Grain Elevator*.



Figure 15. Grain Elevator on a 1950's Canadian one dollar bill. Retrieved from <http://hubertbrooks.com/photos/zAppendix%20A/OldDollarBill2.jpg>



Figure 16. Gabled roof and cupola of the Feed Elevator with 'University of Saskatchewan' sign. Retrieved from <http://www.waymarking.com/gallery/default.aspx?f=1&guid=cb8977bd-d531-46e3-940f-863672e815e3&gid=2>

2.6 Use(s)

The university's Feed Elevator carried out some of the common functions of an elevator as well as some additional functions. The Feed Elevator shares with the Primary Elevator its weighing and storage functions, but in addition, it was equipped with a 50 horsepower hammer mill for grinding as well as a small grain cleaning unit and a mixer. The weighing and cleaning of the grain took place on the ground level. Mixing was undertaken on the upper floor. Figure 9 depicts all of the equipment that was required to carry out the weighing and storage of grain.

When the Feed Mill was opened at the University of Saskatchewan in 1964, the elevator was no longer needed for mixing and became solely a grain storage facility. It continued in this capacity until the 1990's when it became obsolete. The Feed Elevator is no longer used for grain processing and storage. The office shed is used for equipment storage by the Plant Sciences Department. After its decommissioning, the Feed Elevator was used briefly for school tours, but these are no longer conducted due to the condition of the building.

An elevator is built to last about 40 years or approximately the time needed to process 4 – 5 million bushels. The wear caused by repeated filling and emptying weakens the structure and ultimately shortens its life. The Feed Elevator was used from its construction in 1951 until the mid 1990's - just over 40 years of service.

2.7 Cultural & Chronological Associations

The Feed Elevator is associated with the history of the agrarian settlement of the prairies and with the history of agricultural education at the University of Saskatchewan. At the peak of their use, in 1938, there were 5,758 grain elevators licensed in the three prairie provinces of Manitoba, Alberta and Saskatchewan (Silversides, 1997). Although the classic primary elevator type is declining rapidly in number, it remains an iconic symbol of the prairie provinces.

3. Associated Objects

The only significant objects associated with the Feed Elevator are its remaining mechanical systems. These include the scale, the crank controlling the leg above the bins and the machinery on the second storey. See Section 2.6 Systems.

4. Supporting Documents

Bell, J.M. (1996). *Hoofprints to Reprints: The History of Animal Husbandry, Animal Science and Animal and Poultry Science, University of Saskatchewan 1909-1989*. Saskatoon: The College of Agriculture, University of Saskatchewan.

Christensen, D. Personal Communication. July 10, 2012.

Facilities Management Division (2011). Asset Resource Database [Data File]. Retrieved from \\usask\fmddfs\files\iis\IIS_Public\ARS

Silversides, B.V. (1997). *Prairie Sentinel The Story of the Canadian Grain Elevator*. Fifth House Ltd.: Calgary.





5. Summary of Character - Defining Elements

Materials

- cedar structure
- cedar roofing shingles
- aluminum shingle cladding
- steel equipment
- painted wood doors and windows

Form & Style

- 'primary elevator' form
- basilica shape – tower with lean-to shed structures
- shed and gabled roofs
- 75 foot height
- lack of ornamentation

Location

- University of Saskatchewan

Spatial Configuration

- granary or tower
- drive shed & ramps
- drive shed doors
- office/engine room

Systems

- crank
- scale and scale stand
- grain handling equipment: legs, pans, grain belt etc.
- cribbed walls

Uses

- grain storage, mixing, grinding, weighing and cleaning

Cultural & Chronological Associations

- 'University of Saskatchewan' sign
- history of agrarian settlement of the prairies
- history of agricultural education at the University of Saskatchewan

644

Memorial Gates

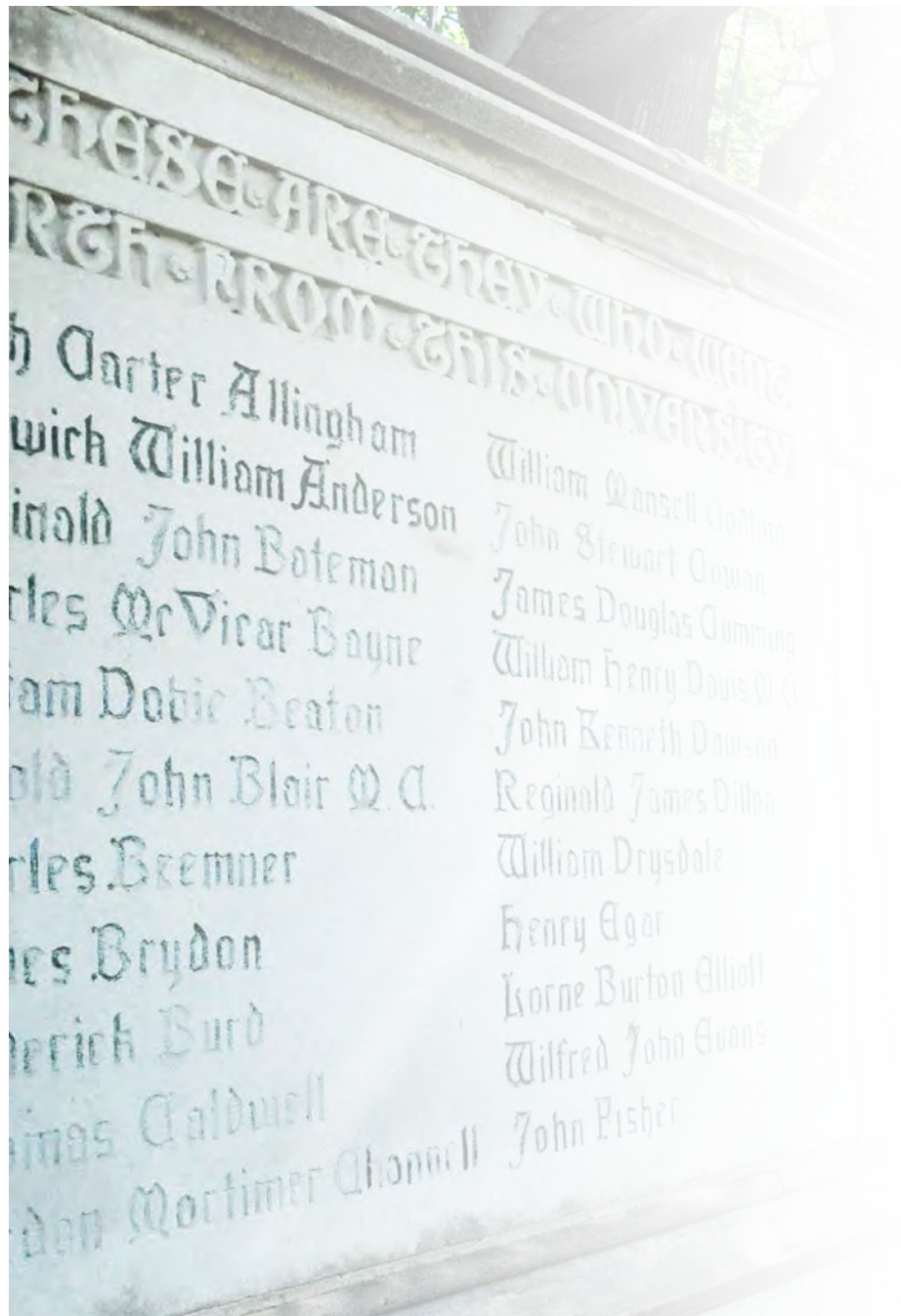

Memorial Gates

Alternate Names

University Gates
Memorial Tablets

Architect(s)

David R. Brown, Montreal

Builders

R.J. Arrand Contracting Company

Construction Dates

1927-28

Recognition

University of Saskatchewan 'A' Listing Recommended

1. Statement of Significance

The Memorial Gates at the University of Saskatchewan were built between 1927 and 1928, and are, as their name suggests, both a memorial to the students and faculty who lost their lives in the First World War, and a ceremonial gate marking the original main entrance to the university. The Memorial Gates today are a reminder of the university's history and of its place in world history. David R. Brown, whose architectural firm Brown and Vallance developed the 1909 Campus Plan and designed all of the university's early buildings, also designed the Memorial Gates.

Three hundred and forty five students and faculty from the University of Saskatchewan served in the First World War. Of these, sixty-nine gave their lives. The Memorial Gates were first proposed in 1923 by the Graduate Students' Society to commemorate the university's fallen soldiers. With the support of President Walter Murray, the students undertook a fundraising campaign. Approximately one third of the \$30,000 cost of the project was paid for by the Graduate Students' Society.



Figure 1. Greystone showing signs of deterioration in the mortar joints. The right half of the photograph shows an attempted repair using inappropriate material.

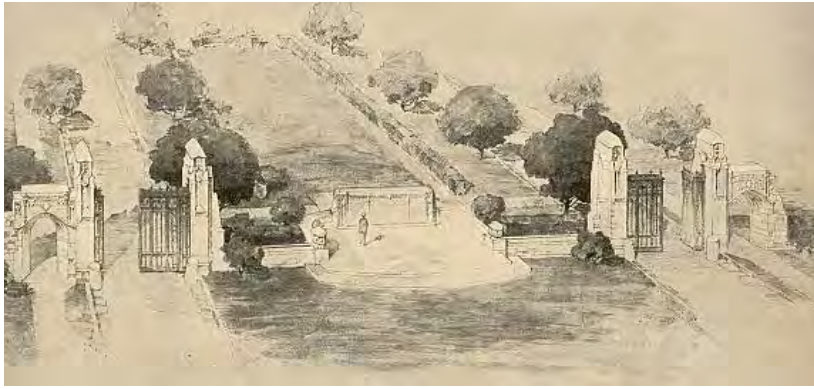

Figure 2. The Memorial Gates as proposed by architect David R. Brown. The Gates were not built exactly as shown. Photo A-5946, retrieved from http://scaa.sk.ca/gallery/uofs_buildings/

The Memorial Gates are designed in the Collegiate Gothic style, built in local 'greystone', with carved ornamentation and copings in Indiana limestone. The gates themselves are of solid bronze, and were built in and imported from England. The Memorial Gates have cultural and historical value in their symbolic function as an entrance to the university and as a tribute to soldiers who were killed in the First World War. The raised cenotaph is a character-defining element, along with its inscriptions and list of fallen soldiers. The cenotaph originally listed 67 soldiers. Two names were mistakenly omitted from the list, but were added in 2013. Other character-defining elements include the location of the Gates at the original entrance to the university, the features that reflect the Collegiate Gothic style of architecture and the materials of the gates.

2. Character - Defining Elements

2.1 Materials

The Memorial Gates are built of materials common to the University of Saskatchewan campus. The walls and piers are built primarily with local 'greystone' (Figure 1). Indiana limestone is used for cut stone trim and decoration (Figures 3 and 4). (For further information on building stones used at the U of S, refer to ['Appendix: Stone'](#).) The cenotaph panels, which list the names of the deceased soldiers, are also made of Indiana limestone. The carved names were originally to be filled with lead, but this specification was never carried out. The gates themselves are constructed of bronze, and are suspended from four stone piers (Figure 5). The gates were manufactured in Cheltenham, England and were shipped to Canada. They each measure roughly 4.5 x 2.9 metres, and weigh over a thousand kilograms. Although weathered, the bronze components are in excellent condition. A base and a set of bollards are made of grey granite (Figure 6).



Figure 3. Indiana limestone showing signs of deterioration.



Figure 4. Limestone showing surface staining and corrosion.



Figure 5. Bronze gates.



Figure 6. Granite bollard.



Figure 7. Sketch by University Architect David Brown showing the symmetry of the design. Photo A-8523. retrieved from http://scaa.sk.ca/gallery/uofs_buildings/



Figure 8. Gothic arch marking a pedestrian pathway.



Figure 10. Keyhole arch motif.

The physical condition of the Memorial Gates was recently assessed by the Facilities Management Division. This assessment noted that a combination of differential settlement and water ingress has caused cracking and spalling in many of the Indiana limestone elements (Figure 3). Surface staining and corrosion as a result of pollution and the build-up of organic materials is evident (Figure 4). Mortar joints are substantially deteriorated and require repointing. Attempts at repair have been undertaken with inappropriate materials (Figure 1). Cleaning and repairs were undertaken in 2013 to address these concerns.

2.2 Form & Style

The Memorial Gates consist of a pair of ornate bronze gates in a low stone wall. Each gate is flanked by a pair of stone piers, about 6.4 metres tall. Each pair of gates defines an opening 5.5 metres wide, which originally formed a vehicular entrance to the university grounds. A slightly raised tablet forms the central feature of the composition, a cenotaph on which are inscribed the names of soldiers from the university killed during the war. The two outermost piers are each buttressed by a pointed arch marking a pedestrian path. The symmetrical composition of the Memorial Gates is a character-defining element (Figure 7).



Figure 9. Stone pier, decorated with carved stone references to statuary niches, keyhole and gothic arches.

The Memorial Gates are Collegiate Gothic in style. This is most clearly apparent in the verticality of the stone piers and in the pointed arches marking the pedestrian walkways (Figure 8). Gothic motifs such as shields, buttresses, keyhole and pointed arches are all referenced in the form of the monument and in its carved stone decoration (Figure 9 & 10). Much of the cut stone decoration features flora such as cereal plants and flowers (Figure 11). Stone string courses and quoining are also characteristic features of the Gothic style (Figure 4).

Those features that reflect the Gothic style of architecture, such as vertical lines, symmetrical massing, Gothic stone tracery, and the decorative motif of the pointed arch are character-defining elements. As well, the craftsmanship involved in the stonework and bronze is a character-defining element contributing to the heritage value of the monument.

2.3 Location & Spatial Configuration

The site of the Memorial Gates marks the original main entrance to the campus, in a location close to that laid out in the 1909 Campus Plan by Architects Brown and Vallance. In that plan, a preliminary version of the gates formed the beginning of a grand axis, aligned with Convocation Hall, a monumental building proposed as the focal point of the campus, but never built. Figure 12 shows the originally intended scale and location of the gates. The grand axis imagined in the 1909 Campus Plan was eventually abandoned, and the Royal University Hospital was built on part of the land originally proposed for this feature. Figure 13 shows the location at which the gates were actually sited; very close to the original plan.

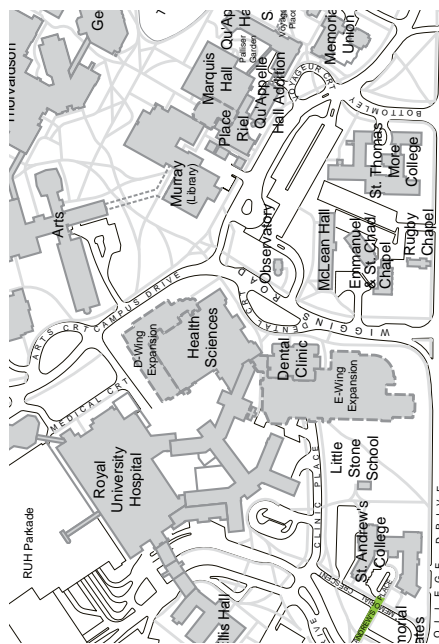

Figure 13. The location of the Gates is indicated in green on this contemporary campus map. The plan is oriented with North to the left.

By 1957, a new master plan for roadways on campus had completely altered the original concept of a formal, Beaux-Arts plan, and the Memorial Gates had become the entrance to the hospital.



Figure 11. Carved stone reliefs feature flora and shields.



Figure 12. The gates originally planned by Brown and Vallance on the 1909 Campus Plan. Plan oriented with north to the left.

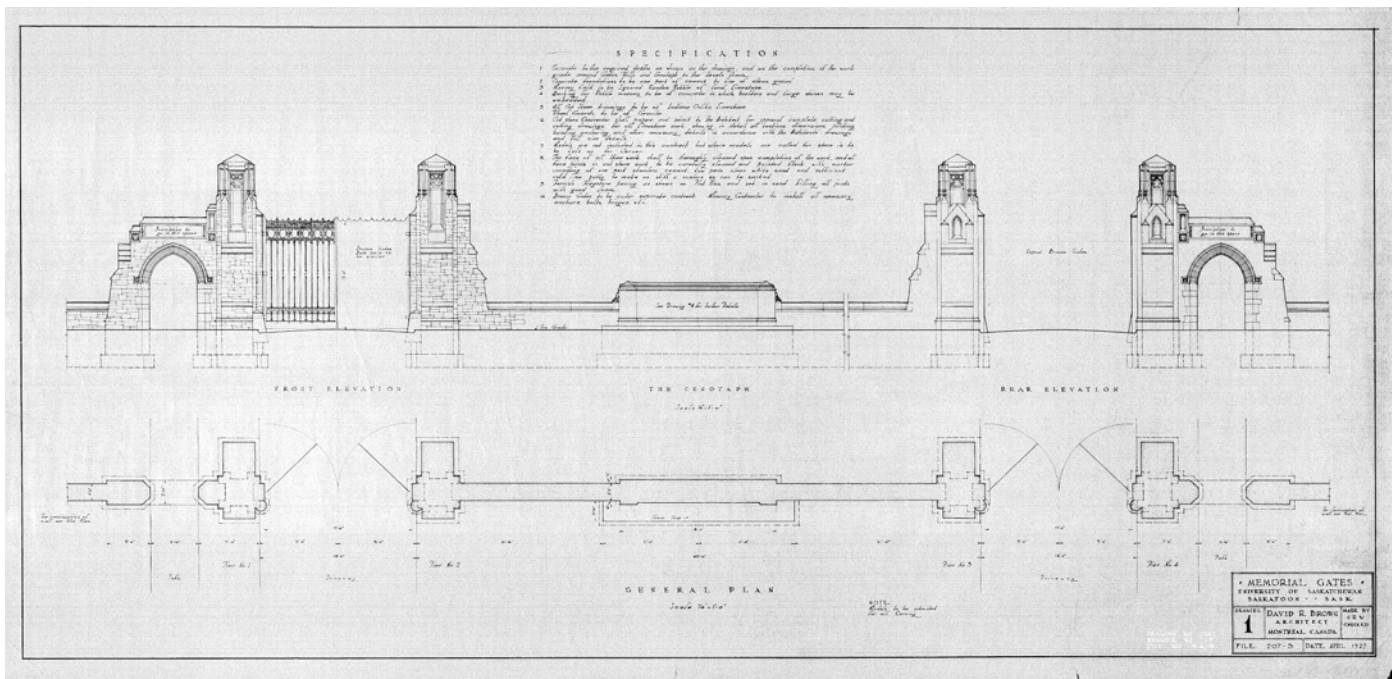

Figure 14. Front elevation and plan drawing, dated 1927. Retrieved from Facilities Management Division Asset Record System, File MG-4-T.

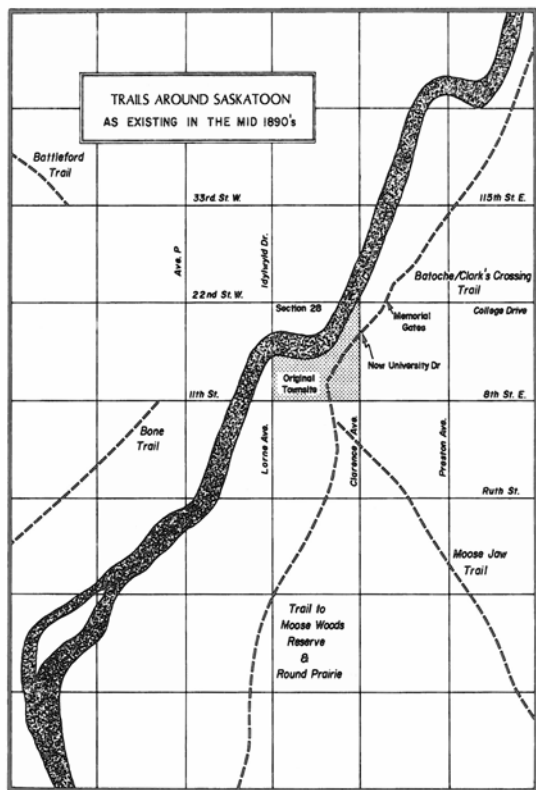

Figure 15. Map of Trails Around Saskatoon as Existing in the Mid-1890's. (Image: *Saskatoon History*, No. 1, 1980. John Duerkop and Michael Bourassa).

Before the development of the railroad system in Saskatchewan and the agrarian settlement of the province, an extensive system of overland trails connected various aboriginal communities and fur trading posts. A trail from Moose Woods to Batoche crossed the current site of the University of Saskatchewan, where it joined the South Saskatchewan River on its way north. In the 1800's, this was a busy route travelled by Metis, Sioux and Dakota people to Batoche and to the Cree settlements near Duck Lake. The trail followed the route of what are now Broadway Avenue and University Drive. The Memorial Gates were later built at the location where this trail crossed onto the site of the university (Figure 15).

In its current configuration, the gates are very much diminished from their former status as the university's formal gateway. Over time, the development of the Royal University Hospital has disconnected it from the university campus. The road networks of the hospital and the university are now separate, such that the gates no longer form an entrance to the university campus. Also, with the re-orientation of roadways to circumvent the Memorial Gates, neither pedestrian nor vehicular traffic is really served by them any longer.

In the late 1980s various plans were considered to help ease the flow of traffic through the area, including moving the memorial Gates to another area of campus. The design finally adopted left the gates in their original location as a pedestrian entranceway, with traffic re-routed to the west.

The location of the Memorial Gates is a character-defining element, due to their original function as the main entrance to the university, due to their relationship to the 1909 Campus Plan and due to their position relative to the historical Moose Woods to Batoche trail.

2.4 Systems

As a structure, the Memorial Gates are constructed as a low stone wall, with stone piers supporting the bronze gates and a stone arch on either side. The stone structures sit on shallow cast-in-place concrete foundations and footings. Over time, differential settlement of the concrete footings caused damage to the material integrity of the structure; however, this damage was substantially repaired in 2013.

2.5 Use(s)

The Memorial Gates serve the commemorative purpose of remembering students and faculty members who gave their lives during the First World War. Remembrance Day services are still held at the Memorial Gates on November 11 of each year.

As described in Section 2.3, Location & Spatial Configuration, the Memorial Gates were originally used as a ceremonial entrance to the university intended for use by vehicles and pedestrians. Changes to the road networks serving the hospital and the university have altered both the physical and symbolic relationship between the Memorial Gates and the university.

2.6 Cultural & Chronological Associations

The Memorial Gates are most directly associated with the First World War and with the university's role in that conflict. The impact of the First World War on the university was significant. In all, three hundred and forty five students, faculty, staff and alumni served during the war, a number roughly equal to the entire first-year class of 1913. In 1916-17, the Engineering Department was temporarily closed, because all of its students and faculty had enlisted. Of the soldiers who served, sixty-nine were killed, and the Memorial Gates were built in their memory. Figure 16 is a photograph of the inscribed names of the lost soldiers. An inscription on the Gates read: "These are they who went forth from this University to the Great War and who gave their lives that we might live in freedom." The battles in which university men took part are listed on panels on either side of the cenotaph: 'Ypres, Somme, Vimy, Paschendale, ...Dury, Amiens, Cambrai' (Figures 18 & 19).

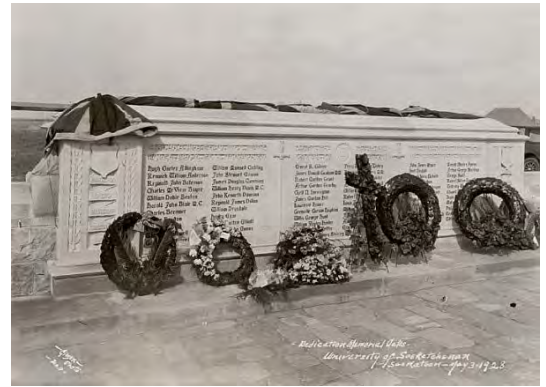

Figure 16. The Gates being used as memorial at their unveiling, May 3, 1928. Photo A-532, retrieved from http://scaa.sk.ca/gallery/uofs_buildings/



Figure 17. The gates being used by students in the 1940's. Photo A-536, retrieved from http://scaa.sk.ca/gallery/uofs_buildings/



Figure 19. Inscription on the west side of the cenotaph.



Figure 18. The cenotaph, listing the fallen soldiers.

Originally, the cenotaph only had sixty seven names inscribed on it. Research done by Professor Emeritus Michael Hayden in the early 2000's revealed that two names had been missed during the original mason work. In 2013, the two missing names, George Israel Peters and Herbert Ernest McRitchie, were added to the tablet (figure 20).



Figure 20. A stone mason carving one of the forgotten names of the fallen soldiers onto the memorial tablet, 2013. Photo retrieved from http://news.usask.ca/wp-content/uploads/2013/09/2013-09-13_web.pdf

The Collegiate Gothic style of the Memorial Gates derived from the mediaeval European precedents of the monastery and cloister, translated particularly through the college buildings of Oxford and Cambridge Universities, and imported to North America in the designs of American universities such as Princeton and Yale. The style declared the new university's link to an ancient academic and cultural tradition and the Memorial Gates made that declaration from the moment one entered the campus.

Frederick W.O. Haultain's ashes are buried near the gates. Haultain was the second Chancellor of the university from 1917 to 1939 and held that position when the Gates were erected. The proximity of the gravesite associates the Chancellor with the Gates. Figure 21 depicts Haultain's headstone.



Figure 21. Gravesite of Sir Frederick Haultain. Photo A-8778, retrieved from http://scaa.usask.ca/gallery/uofs_buildings/

3. Supporting Documents

- Author Unknown. (October 5, 1928). Gates of Glory. *Winnipeg Free Press*, pp.17. Retrieved from <http://archives.winnipegfreepress.com/RegistrationLockdown.aspx?ctl=search&returnurl=Search.aspx>.
- Duerkop, John & Lisa Dahlie Lough (1980). 'Along the Trails to Saskatoon.' *Saskatoon History*, Saskatoon Heritage Society, Saskatoon. Issue No. 1, 1980.
- Facilities Management Division (2011). Asset Resource Database [Data File]. Retrieved from <\\usask\fmddfs\files\iis\IIS Public\ARS>
- Hayes, P. (September 23, 2005). Gates Were Early Campus Entrance. *On Campus News* 13 (3). Retrieved from http://news.usask.ca/archived_ocn/05-sep-23/column_archives.shtml
- Lomheim, S. (2011). Gates of Glory, *Saskatoon History Review*, 24, 28-31.
- Mysyk, W.K. & Kulyk, C.L. (2006). *Saskatoon's Stone*. Saskatoon: Houghton Boston Printers & Lithographers Ltd.
- University of Saskatchewan Archives. Buildings and Grounds Department 2015, 9, Memorial Gates.
- University of Saskatchewan Archives. President's Office Fonds, Series VI. I. Acad. And Admin. 8. VP SP. Pro. I DI and Dev. 8-3: Memorial Gates 1986-1989.
- University of Saskatchewan Archives. President's Office Fonds, Series I. B. Name and Subject Files 71. Memorial Tablets and Gates (1918-1928).
- Wallace, A. (2006). *Memorial Gates, University of Saskatchewan Report on Physical Condition and Heritage Significance*. Retrieved from Facilities Management Division, University of Saskatchewan.
- MacPherson, C. (September 13, 2013). Gates Repaired, Missing Names Finally Added. *On Campus News* 21(2). Retrieved from http://news.usask.ca/wp-content/uploads/2013/09/2013-09-13_web.pdf



4. Summary of Character - Defining Elements

Materials

- greystone walls & piers
- cut and carved Indiana limestone trim and ornamentation
- granite bollards and base
- bronze gates and hardware

Form & Style

- features that reflect the Collegiate Gothic style of architecture
- verticality of stone piers
- pointed archways
- symmetrical massing
- Gothic stone tracery
- Gothic motifs: pointed arches, keyhole arches
- central cenotaph & plaques
- low 'wing walls'
- piers
- statuary niche references
- reliefs of local flora
- quoining in stonework

Location & Spatial Configuration

- location at original entrance to the University,
- location in relation to 1909 Campus Plan
- position on axis with University Drive
- pedestrian and vehicular gateways
- low 'wing walls'
- central cenotaph

Uses

- Remembrance Day services
- wreath laying
- entrance to university

Cultural & Chronological Associations

- features that relate to its function as a memorial to the university's war dead, such as the raised cenotaph with inscriptions and list of fallen soldiers
- gravesite of Frederick W.O. Haultain
- symbolic entrance to the university



647

Diefenbaker Grave Site



647

Diefenbaker Grave Site

Alternate Names

N/A

Architect(s)

N/A

Builders

N/A

Construction Dates

August 22, 1979

Recognition

University of Saskatchewan 'A' Listed

1. Statement of Significance

The grave of John George Diefenbaker is located at the University of Saskatchewan, on the bank of the South Saskatchewan River and the grounds of the Diefenbaker Building. Diefenbaker was Canada's 13th Prime Minister, serving from June 21, 1957, to April 22, 1963. He was born in Ontario, but raised in Saskatchewan, where his interest in politics began at a young age. He attended the University of Saskatchewan from 1912 until 1919, ultimately earning three degrees.

The gravesite has heritage value due to its cultural and chronological associations with John Diefenbaker and with the history of his time in office. Diefenbaker is remembered for his legacy of advancing civil rights and for his vision of 'One Canada,' as well as for the controversy surrounding the cancellation of the Avro Arrow project. Diefenbaker died in August 1979 and was buried with his wife, Olive whose remains were moved from Ottawa to Saskatoon at his request. The location of Diefenbaker's grave at the University of Saskatchewan serves to commemorate his place in Canadian history, and his long association with the University of Saskatchewan and the Province of Saskatchewan.

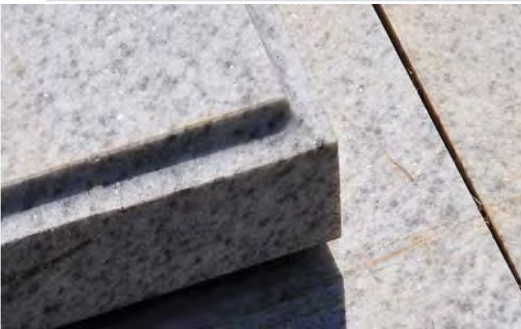

Figure 1. Granite grave stone.



Figure 2. Form and style of the grave stone.

2. Character - Defining Elements

2.1 Materials

The grave marker is a low stone tablet made of granite (Figure 1). The granite gravestone is in excellent commemorative condition. A bronze plaque commemorating both Diefenbaker and the 125th anniversary of Confederation was added in 1992. Both the gravestone and the bronze plaque are character-defining elements.

2.2 Form & Style

The grave marker takes the form of a modest rectangular plinth raised slightly from the ground. Surrounding it is a ring of rectangular granite flagstones set flush with the adjacent earth. A small patch of earth is left open as a flower bed. A simple inscription reads 'Diefenbaker', followed by the given names 'John George' and 'Olive Evangeline', and the years of their lives. The inscription on the marker faces up, and there is no ornamentation. The simple form of the grave marker is a character-defining element (Figure 2).

2.3 Location & Spatial Configuration

Diefenbaker's grave is located on a knoll in an open space between the South Saskatchewan River and the Diefenbaker Canada Centre (Figure 3). At Diefenbaker's funeral, Prime Minister Joe Clark began his eulogy, "John Diefenbaker is home." At the former Prime Minister's request, his body was transported by train after his death to be buried at Saskatoon. In January, 1979 he had written to the provincial government and to the university's Board of Governors, asking permission to be buried at the university. A small plot of land near the planned site of the Diefenbaker Canada Centre was set aside to accommodate this request.

The planning for the Diefenbaker Centre was already well underway at the time of his passing. In 1969, Diefenbaker announced he would donate his papers to the university. That gift led to the design and eventual construction of the Centre. The building was modeled on the presidential libraries of the United States, and was planned to house artifacts, personal and parliamentary papers, and a library. It was completed in 1980, about a year after Diefenbaker's death.

The gravesite sits overlooking the river and the city, and is publicly accessible. The openness and accessibility of the site are character-defining elements (Figures 4 & 5).



Figure 3. The location of Diefenbaker's grave site is indicated in green on this portion of a contemporary campus map.



Figure 4. Context of the grave site.



Figure 5. View from Diefenbaker's grave.



Figure 6. Grave stone.



Figure 7. Diefenbaker's name in the MacKinnon Building.



Figure 8. Diefenbaker's graduand photo, ca. 1919. Photo A-3358, retrieved from University of Saskatchewan Archives.



Figure 9. Diefenbaker in the House of Commons. Photo retrieved from http://en.wikipedia.org/wiki/John_Diefenbaker

2.4 Cultural & Chronological Associations

Diefenbaker's gravesite is associated with John Diefenbaker, and with the history of his time in office. Diefenbaker was born in 1895 in southwestern Ontario, to William and Mary Diefenbaker. In 1903, his family moved to Fort Carlton, then part of the Northwest Territories, but now part of Saskatchewan. The family lived in various rural communities before finally settling in Saskatoon. Diefenbaker showed interest in politics from a young age. As a boy of 8 or 9, he told his parents that he would become Prime Minister. Diefenbaker was fond of relating that his first interaction with politics came at the age of 10 when he sold a newspaper to Prime Minister Sir Wilfrid Laurier, who was in Saskatoon to lay the cornerstone for the university's first building (now the [MacKinnon Building](#)). When giving his speech that afternoon, Sir Wilfrid commented on the newsboy who had ended their conversation by saying, "I can't waste any more time on you, Prime Minister. I must get about my work."

In 1912 Diefenbaker entered the University of Saskatchewan to study arts and law and received his Bachelor of Arts in 1915. He returned for his Masters of Arts in political science and economics the following autumn. Diefenbaker convocated in May 1916. In August 1916 he enlisted in officers training so that he might serve in the First World War. Commissioned as a lieutenant in the infantry, Diefenbaker sailed to England where he served as a member of the 196th Battalion (Western Universities) before returning to Canada in February 1917. A terra cotta frieze in the [MacKinnon Building](#) commemorates all those who served in the First World War, including Diefenbaker (Figure 7). In May 1919, Diefenbaker received a degree in Law, making him the first student at the university to receive three degrees (Figure 8).

Diefenbaker began his political career while working as a lawyer at a firm that he founded in Wakaw. He ran as a Conservative Party candidate several times during the 1920's and 1930's, becoming a member of parliament in 1940. Diefenbaker ran as the leader of the opposition in the 1957 election, winning a minority. He took office as Prime Minister of Canada on June 17, 1957. In 1958 he called a snap election, securing a majority government, and won another minority in 1962. 'Dief the Chief' as he came to be known, was a champion of civil liberties and his legislative program reflected this. He secured passage of the Canadian Bill of Rights, the first step towards the Canadian Charter of Rights and Freedoms. He was the first Prime Minister to appoint a woman to cabinet and appointed the first aboriginal person to the Senate. He secured for aboriginal people the right to vote. He also successfully amended the Criminal Code to include two categories of murder and to limit the death penalty to a narrow range of deliberate acts. His vision of "One Canada" is summarized in his statement, "All through my life, one of the things I've tried to do is to bring about in this nation citizenship not dependent on race or colour, blood counts or origin."

Diefenbaker's term ended on April 8, 1963. He served as leader of the opposition until 1967 and was an MP until his death. John Diefenbaker died in Ottawa on August 16, 1979 and was buried six days later on the banks of the South Saskatchewan River at the University of Saskatchewan (Figure 10).

3. Associated Objects

Many objects held by the university are associated with Diefenbaker and his gravesite. The oldest associated object is the terra cotta scroll commemorating university students and faculty who served in the First World War. (See Section 2.8 Cultural and Chronological Associations).

Diefenbaker's graduand photo from law school is located in the University of Saskatchewan Archives. Diefenbaker's personal papers and other memorabilia are held in the Diefenbaker Canada Centre. The Centre and its collections are associated with the nearby gravesite.

A bronze plaque commemorating Diefenbaker and the 125th anniversary of Confederation was added to the grave stone in 1992 (Figure 11).

A memorial plaque was unveiled in 2000 (Figure 12). The plaque reads: "Right Honorable John George Diefenbaker (1895-1979). John Diefenbaker, a prairie populist and spellbinding speaker, advocated that all Canadians should be "unhyphenated Canadians." He served as prime minister from 1957 to 1963. In 1958, he won the greatest electoral victory in the history of Canada's House of Commons."



Figure 10. State funeral for John G. Diefenbaker. Photo A-10072, retrieved from University of Saskatchewan Archives.



Figure 11. Grave site plaque.

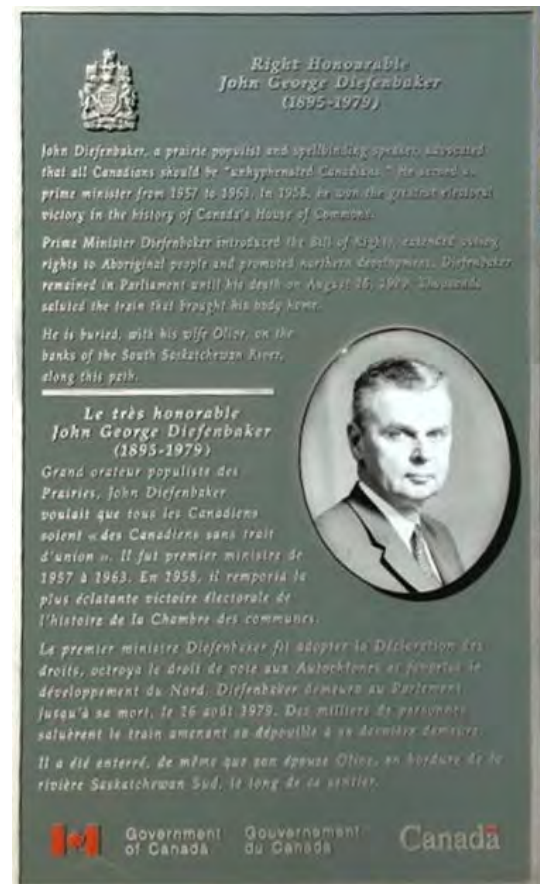

Figure 12. Memorial plaque.

4. Supporting Documents

Author Unknown. (Retrieved 2012). *John Diefenbaker - Wikipedia*. Retrieved from http://en.wikipedia.org/wiki/John_Diefenbaker

Author Unknown. (September 1, 2000). New plaque marks Dief's grave. *On Campus News* 8(1). Retrieved from http://news.usask.ca/archived_ocn/sept1-00/news12a.shtml

Author Unknown. (Aug 17, 1979). State Funeral Set for Diefenbaker. *The Globe and Mail*, retrieved from <http://v1.theglobeandmail.com/series/primeministers/stories/obit-JD.html>.

MacPherson, P. (October 18, 2002). Campus Final Resting Place for At Least 3 Souls. *On Campus News*, 10(5). Retrieved from http://news.usask.ca/archived_ocn/07-oct-05/12.php.

Smith, D. (Retrieved 2012). *Diefenbaker John George*. Retrieved from <http://www.biographi.ca/009004-119.01-e.php?BioId=42125>

University of Saskatchewan Archives. (Retrieved 2012). *Events in the History of the University of Saskatchewan: 1979 Diefenbaker Funeral*. Retrieved from http://scaa.usask.ca/gallery/uofs_events/articles/1924.php



5. Summary of Character - Defining Elements

Materials

- granite grave stone
- bronze plaque

Form & Style

- rectangular raised marker
- simplicity of form and lack of ornamentation

Location & Spatial Configuration

- site at the University of Saskatchewan
- site overlooking South Saskatchewan River
- open and publicly accessible site

Cultural & Chronological Associations

- Canadian Prime Minister
- Progressive Conservative Party of Canada
- University of Saskatchewan alumnus
- First World War



932

St. Andrew's College

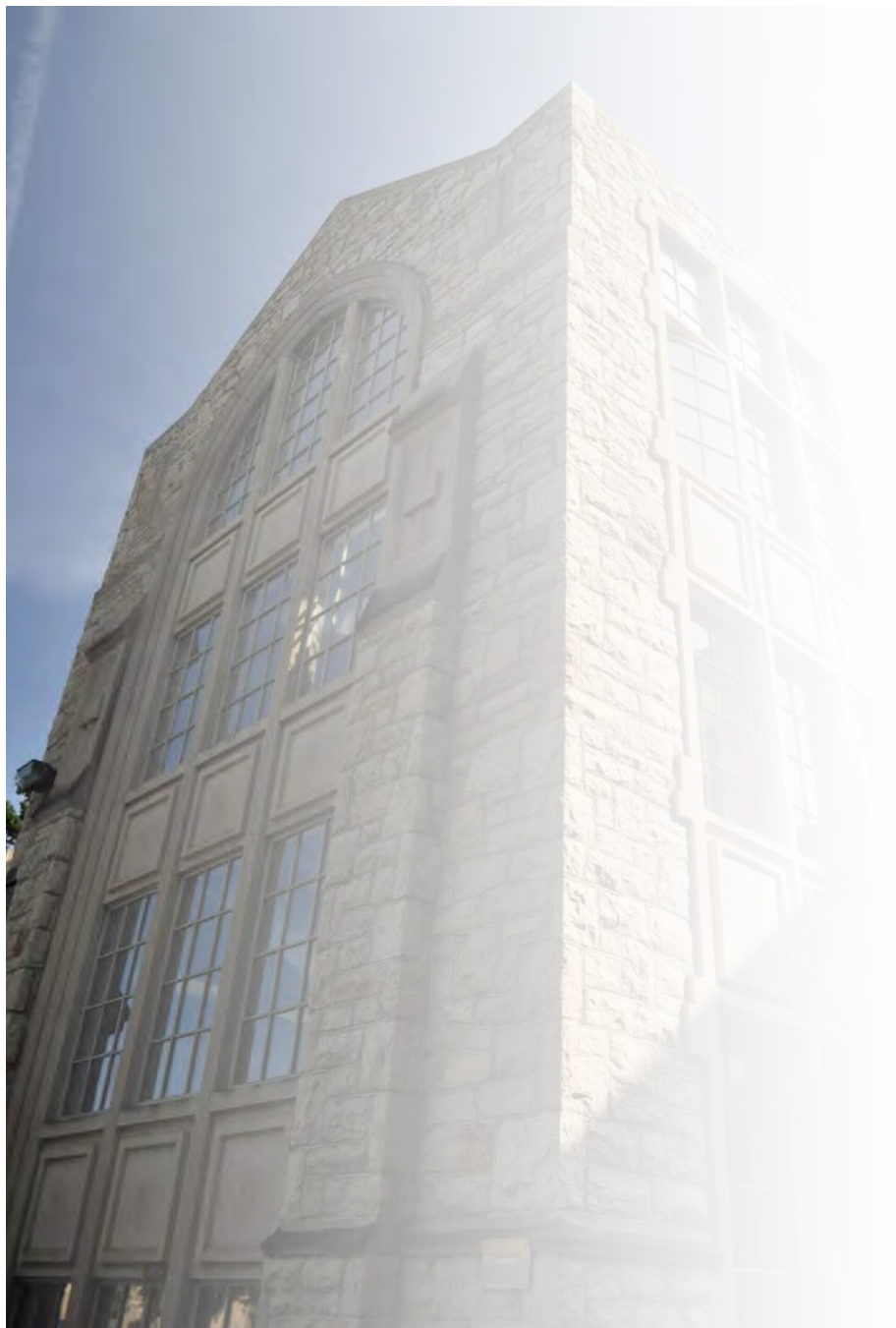

932

St. Andrew's College

Alternate Names

Presbyterian Theological College

Architect(s)

David R. Brown, Montreal

Builders

Smith Bros. & Wilson, General Contractors

Construction Dates

1922-1923, 1959-1961

Recognition

Affiliated College - 'A' Listing Recommended



Figure 1. Greystone walls with Indiana limestone trim and decoration.



Figure 2. Granite steps.



Figure 3. Slate tile roofing.

1. Statement of Significance

St. Andrew's College is a theological college affiliated with the University of Saskatchewan. Founded in 1912 as the Presbyterian Theological College, it began instruction in 1914 with an enrollment of 37 students. During its early years, it operated from a house on Albert Avenue in Saskatoon. Plans for a permanent college building on the university campus were made early, but construction was delayed by the First World War. The building was constructed in two phases. The original building, now the west wing, was designed by David R. Brown and was built between 1922 and 1923. Brown's former architectural firm, Brown and Vallance, had previously developed the 1909 Campus Plan and had designed all of the university's early buildings. In 1925, the institution was renamed St. Andrew's College after the union of the Methodist, Congregational and most Presbyterian Churches formed the United Church of Canada. An addition, the east wing, was designed by the Saskatoon firm of Webster, Forrester & Scott Architects and was built between 1959 and 1961. In its design and location, the St. Andrew's building embodies the close relationship between the theological school and the university. Both the original building and its addition have heritage value in their design and material composition. They are both also excellent examples of Collegiate Gothic architecture, the former representing the style at its



Figure 4. St. Andrew's College ca. 1928 prior to its expansion. The Memorial Gates and the Little Stone School House are visible. Photo PH-93-166-81, retrieved from <http://spldatabase.saskatoonlibrary.ca>

height, the latter representing a period of transition when historical revival styles were becoming anachronistic.

Note: St. Andrew's College is configured with floors numbered Basement, Ground Floor, First Floor, Second Floor and Attic. This report follows the same convention.

2. Character - Defining Elements

2.1 Materials

St. Andrew's College is built of the traditional materials that characterize the University of Saskatchewan campus. The exterior walls are primarily built of 'greystone', with cut Indiana limestone trim, a granite base course and granite steps (Figure 1 & 2). The roofs are clad in slate, and flashing, downspouts and gutters are in copper (Figure 3 & 5).

The windows are framed in wood on the 1922 portion of the building, and in steel on the 1959 portion (Figures 6 & 7). The windows are single-paned, but are arranged in two layers, with an interior and exterior set for each opening. On the 1922 portion of the building, the window frames were originally specified to be painted 'bottle



Figure 5. Copper downspout.



Figure 6. Interior and exterior wood-framed casement windows with brass hardware.

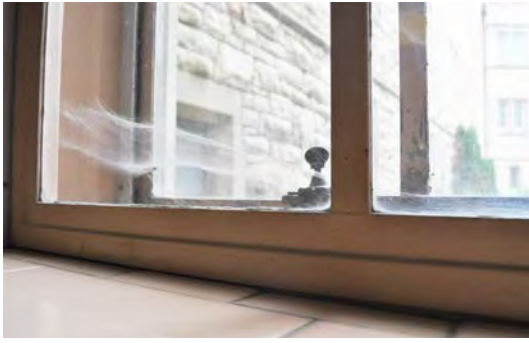

Figure 7. Steel framed windows.



Figure 8. Plaster wall with painted wooden dado and glazed tile wainscoting.



Figure 9. Buff and blue ceramic tile under a steel casement window in the 1959 wing.

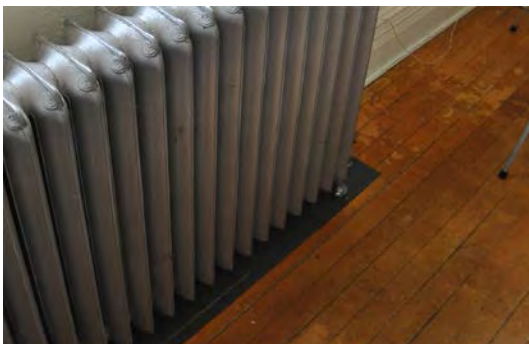

Figure 10. Original maple flooring and cast iron radiator.

green.’ The original window hardware is in bronze or brass. The hardware on the 1959 addition has been fully retained while most of the fixtures in the original wing have been replaced. All of the original exterior wooden doors have been replaced by steel doors.

The original exterior materials of St. Andrew’s College – greystone, Indiana Limestone, slate and copper – are character-defining elements. For further information on building stones used at the U of S, refer to [‘Appendix: Stone.’](#)

The original interior finishes exist in varying states of commemorative integrity. Walls are finished in a painted textured plaster, with wood baseboards and trim. In the older portion of the building, most of the wood trim is intact, but its original dark oak finish is covered by layers of paint (Figure 8). The textured plaster walls are generally intact. In the basement, one wall features a buff glazed tile wainscot (Figure 8). In some rooms, the walls have been covered in carpet but original materials may still exist beneath. A yellow glazed tile was used for wainscoting and backsplashes in the washrooms and still exists in excellent condition. In the 1959 wing, blue and off-white glazed tile was used liberally as wainscoting and window sill finishes, as well as in washrooms. The off-white tile in the 1959 portion of the building is shown in Figure 9. The original plaster, wood trim and ceramic wall tile are character-defining elements.

The floors of the original wing were originally finished in maple, and are still intact in some places. On the ground floor, an office and meeting rooms still feature maple hardwood flooring, which is in fair condition but showing some wear (Figure 10). On the second and third floors, the original hardwood can still be found in the dormitory rooms that are now used as offices.



Figure 11. Red concrete tile and polished dark granite hearth.



Figure 12. Oak door with brass numbering.

These floors are in excellent commemorative condition. Much of the rest of the building has carpet, but the original flooring may still exist underneath.

The newer addition to St. Andrew's College contains some flooring made of red ceramic tile, laid in an alternating pattern. The flooring is found in the common room and the activities lab, (formerly the gymnasium/auditorium). The flooring is worn and cracked in some places, but it retains heritage value (Figure 10). The original flooring materials are character-defining.

In the 1922 portion of the building, the original paneled doors were in oak, finished with a dark stain. In the basement, most of the original doors and frames have been retained. The brass doorknobs, numbers and hinges appear to be original (Figures 12 & 13). The upper floors of the 1922 wing contain a few original doors; however, most have been replaced. In the 1959 wing, doors are of a lighter oak finish, and their hardware matches the 1922 wing (Figure 14). Door frames in the newer wing are in painted wood or steel. The original doors are character-defining elements.

The stairwells in the building have excellent commemorative integrity, although only one dates from the original construction; the rest date from the 1959 addition and renovations. The original stairwell, shown in Figure 15, has treads, landings and thresholds in marble, which is intact and in fair condition. Some of the marble treads and thresholds are worn from frequent use. This stair also features steel stringers, an iron balustrade and an oak banister. Cast iron newel posts are ornamented with details typical of the Collegiate Gothic style (Figures 15 & 25). The later staircases are composed of steel stringers and balustrades, but have treads of terrazzo as shown in Figure 16. The northern entrance and staircase has a wainscoting of buff marble (Figure 17). The staircases and their finish materials are character-defining.

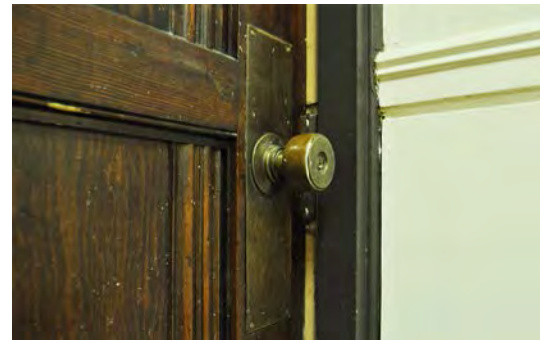

Figure 13. Oak door with brass hardware.



Figure 14. Door materials in the 1959 wing.

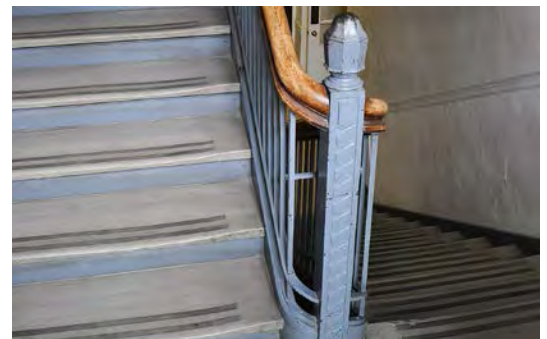

Figure 15. Steel stair and balustrade with oak banister and marble treads.



Figure 16. Aluminum balustrade and terrazzo treads.



Figure 17. Marble wainscoting and aluminum balustrade.



Figure 18. Wood wall panelling in the chapel.



Figure 19. Stained glass window.

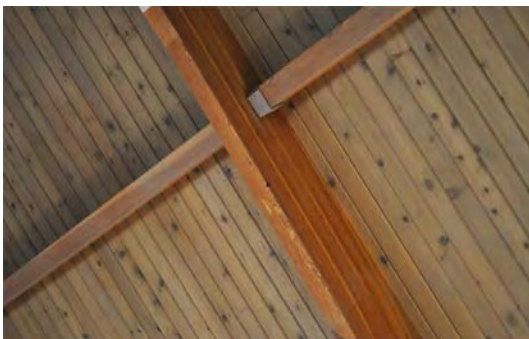

Figure 20. Glue-laminated wooden ribs and wooden decking.

The 1959 addition included the construction of a chapel, which in its form and materiality is distinct from the rest of the building. On the interior, a stained glass window casts a coloured light over the room (Figure 18). Stained glass is also found over the main entrance, as shown in Figure 19. An oak wainscoting surrounds the room. The nave is defined by a pitched roof, supported by a series of distinctive glue-laminated scissor trusses. The bottom chords of each truss take the form of a pointed arch, giving the roof the appearance of a vaulted space (Figure 20). The chapel and its finish materials is a character-defining element.

The student lounge is another room of particular heritage value. It is a double-height space, with a mezzanine level at the west end, illuminated on two sides by tall windows. Oak wainscoting around the perimeter doubles as a radiator cabinet. At the east end there is a striking fireplace and hearth of greystone, with a hearthstone of polished black granite and a mantelpiece of Indiana limestone. A carved limestone shield is set into the stone chimney. The original materials of the lounge and its fireplace are character-defining.

2.2 Form

The form of St. Andrew's College, created by the 1959 addition to the original 1922 structure, is a U-shaped building. The outdoor space enclosed by the U delineates an arrival court. The original wing built is shown in Figure 20. Figure 21 shows the building after the 1959 additions. St. Andrew's is composed formally of three connected volumes. The original building, now known as the west wing, is connected by the east wing to a chapel. The chapel sits at an angle to the rest of the building, which relates in its orientation to the rest of the university as defined by the 1909 Campus Plan. The east and west wings are oriented in relation to College Drive and the city. These two orientations are character-defining elements as they relate the building to the university and to the surrounding city.

All three parts of the building have pitched roofs with gable ends. In scale, St. Andrew's stands about three-and-a-half storeys above grade, including a half-basement and an attic storey. The chapel is of a similar height, but comprises only a basement and a double-height main level. The human scale of the building is a character-defining element.



Figure 21. The form of the 1922 wing. Photo A-769, retrieved from <http://sain.scaa.sk.ca/items/index.php/university-of-saskatchewan-archives;jsdiah>



Figure 22. Architect's sketch of St. Andrew's College with the addition of the 1959 wing. Photo retrieved from St. Andrew's Archive, File STA.I.14.1.1.



Figure 23. Stone string courses.



Figure 24. Gothic arch chapel windows, peaked roof and cut stone ornamentation featuring a cross.



Figure 25. Gothic arch entrance and transom.



Figure 26. Bay windows.

2.3 Style

The 1922 wing of St. Andrew's College was part of the first phase of construction at the University of Saskatchewan, and was designed by David Brown to be an integral part of the campus, in the Collegiate Gothic style. The 1959 addition was designed to match this original conception. The college is built in stone, with typically Collegiate Gothic details such as gabled roofs, stone walls and cut limestone detailing (Figure 21). The exterior of the building is decorated with cut stone crests and ornamentation (Figure 23). The entrances to the building are set into pointed stone archways, one of which is shown in Figure 24. On the north side of the 1922 portion of the building, there is a bay of windows spanning three floors (Figure 25). Dormer windows clad in slate tile line the roof (Figure 26). Early elevations show oriel windows incorporated into the building's west elevation (Figure 28), but these do not appear in any photos of the building after construction. Those features defining the Collegiate Gothic style of the 1922 wing are character-defining elements.



Figure 27. Arched transom and surround, decorative balustrade.

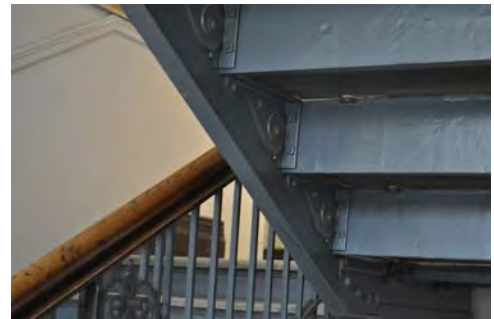

Figure 28. Ornamental iron work.



Figure 29. Dormer windows.

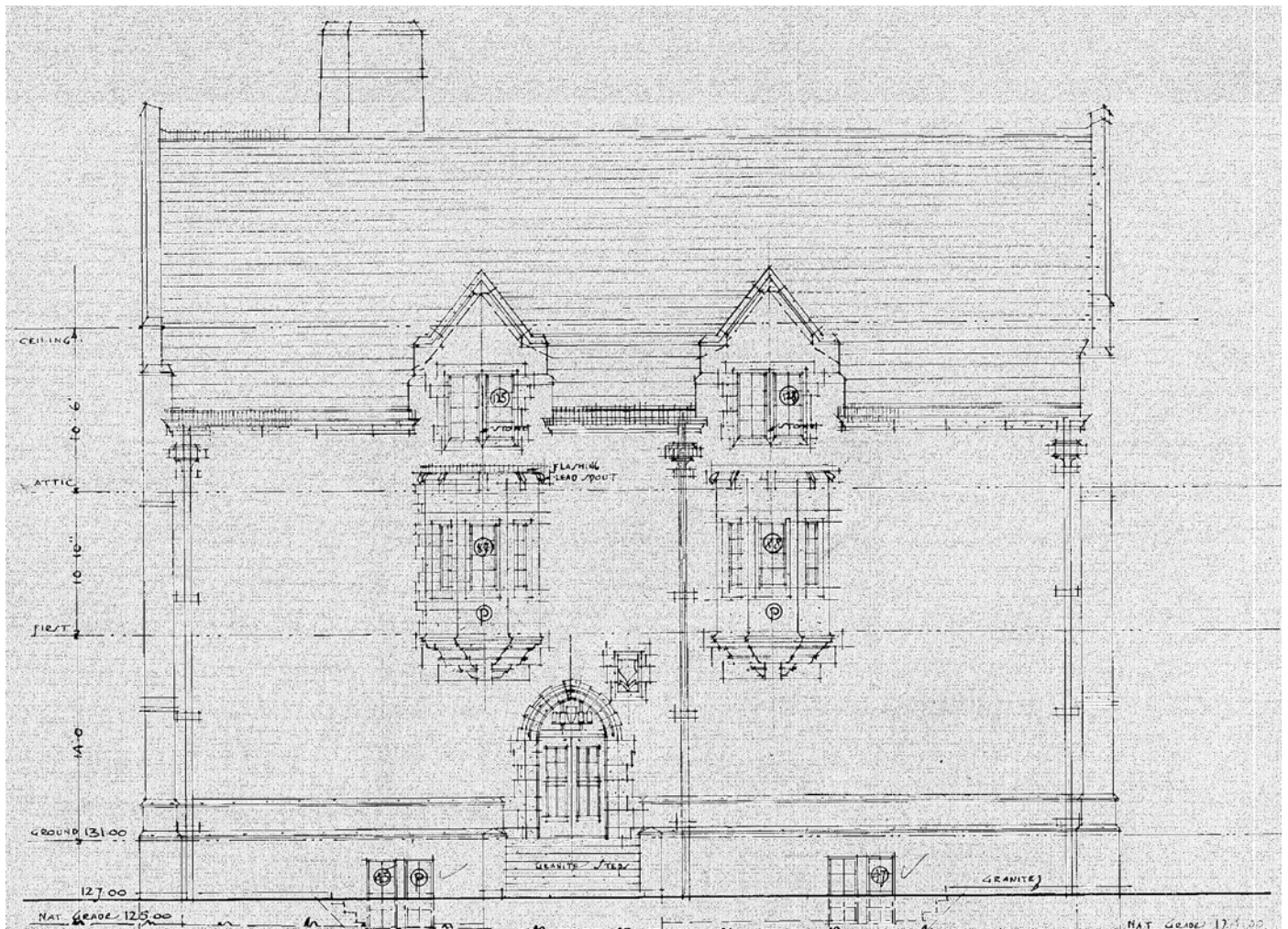

Figure 30. An unrealized elevation showing oriel windows flanking a gothic arched entry. Retrieved from Asset Record System, File SC-95-P.

The 1959 wings were designed to match the style of the original building, but are often simplified in their detailed execution. The doors of the chapel are low in proportion and quite plain, but have traditionally detailed iron hinges (Figure 31). The windows in the chapel, including the large east-facing stained glass panel, are set into pointed arched openings, but also feature plain stone spandrel panels (Figure 24). The north and south walls of the chapel are articulated by a row of simple stone buttresses (Figure 32).



Figure 31. Chapel doors with slot windows.

Figure 32. Stone buttresses.





Figure 34. Picture mouldings.



Figure 35. An arched recess over former hearth.

The interiors of the building are designed in a manner consistent with the character of the building, but in the case of the 1959 addition, are influenced by the prevailing modernist style of the period. The 1922 portions are traditionally detailed.



Figure 33. Interior arch.

A tall arch crowns the staircase at the west end of the original building (Figure 33). Hallways are adorned with wooden baseboards and moldings. Interior rooms have picture rails as shown in Figure 34. In one of the rooms in the 1922 wing, a decorative arch marks the place where a fireplace originally existed (Figure 35). The original drawings show the corridors once had vaulted ceilings, although currently the ceilings in the building are covered in suspended tile (Figure 36). The vaulted plaster ceilings may still exist above the ceiling tile. The same suspended ceilings also obscure the glazed transoms above interior doors; these have all been covered by an opaque material and are no longer operable (Figure 37).

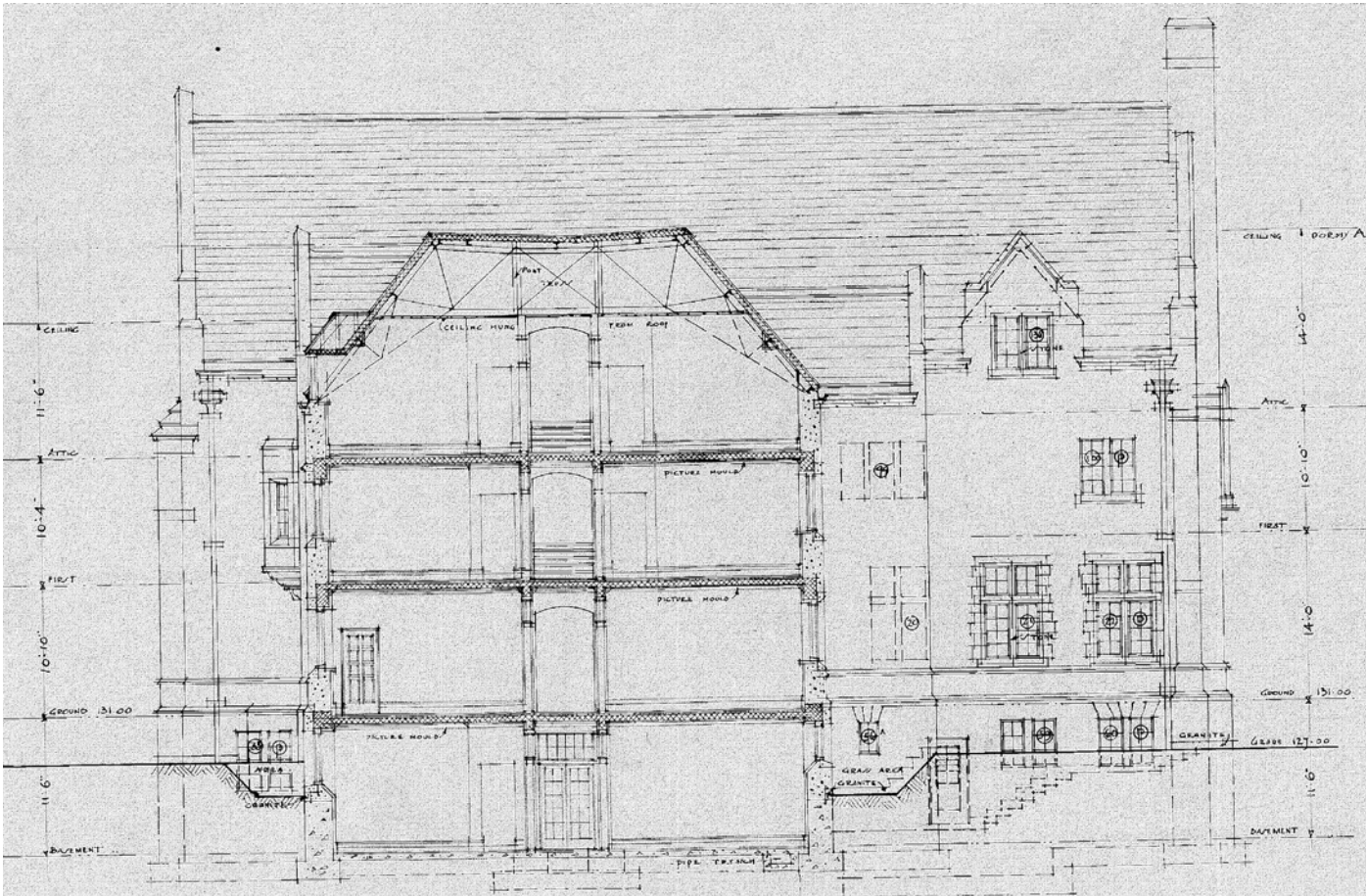

Figure 36. Section through the building showing vaulted ceilings in the corridors.. Retrieved from Asset Record System, File SC-96-P.

The newer portions of the building mix elements of the Collegiate Gothic and modernist styles. The staircases, for example, feature functionalist steel balustrades without decoration (Figure 38). The stair in the student lounge is a lovely minimalist design featuring open risers, shallow terrazzo treads and a light polished aluminum balustrade and handrail. The fireplace in the common room blends modern and traditional elements (Figure 39). It has an exposed greystone chimney that extends the full height of the room. The simplicity and continuity of the mantle shelf is modern, but it is formed of limestone, a traditional material. The carved limestone crest above the mantle is a more traditional flourish.

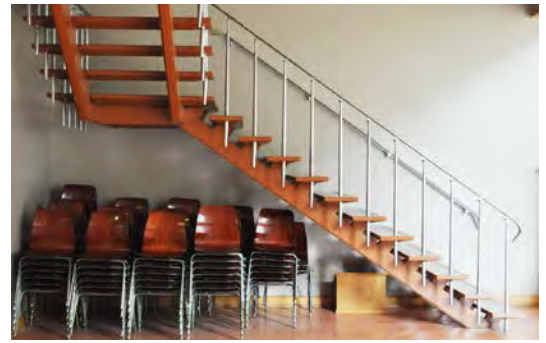

Figure 38. Modernist stair.



Figure 37. A transom window which has been replaced with an opaque glass window, take the form of gothic arches (Figure 42).

The interior details of the chapel also feature characteristics of both the Modern and Collegiate Gothic styles. The roof is supported by a series of glue-laminated wooden scissor trusses, whose lower chords are shaped in the form of a pointed arch, a modern reference to a traditional form (Figure 40). The wainscoting around the chapel walls and other carved oak millwork make reference to the tracery of gothic cathedrals (Figure 41). The windows of the chapel, including the large, east facing stained glass window, take the form of gothic arches (Figure 42).

Both the modern and traditional stylistic elements of the 1959 wings are character-defining elements.



Figure 39. Fireplace with full height, modern mantle and decorative crest.

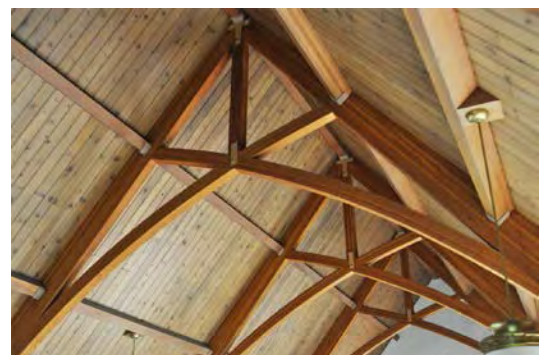

Figure 40. Glue-laminated trusses and wood decking in the chapel.



Figure 41. Gothic tracery in the chapel millwork.

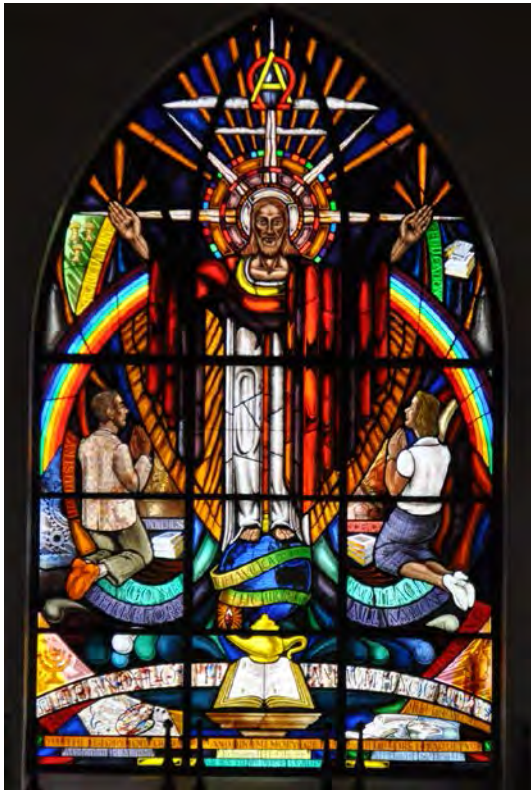

Figure 42. Stained glass window.



Figure 43. Professor Munro seated on the cornerstone of the ill-fated Theological Hall, ca. 1915. Photo ASM-52, retrieved from <http://sain.scaa.sk.ca/items/index.php/university-of-saskatchewan-archives;jsdiah>.

2.4 Location

Plans had begun for a Presbyterian College affiliated with the University of Saskatchewan in 1910. Both Walter Murray, the first President of the university, and Dr. Edmund Oliver, the first Principal of the Presbyterian College, supported the integration of theological study within the greater academic community. In 1911 a site was chosen on the north side of the campus, “as near to the river as the Board of Governors will allow.”

In 1914, 4.5 acres of land was leased by the Presbyterian College from the university at a rate of \$5.00 per year. The lease was to be effective May 1913. The site is described in lease documents to have been near the current location of the Education Building. Materials were acquired and foundations were laid on this site only to have construction interrupted by the outbreak of the First World War. In 1922 the project was resumed; however, the original site was abandoned in favor of donated land located at the southwest corner of the campus. The new location placed the Presbyterian College directly beside the main entrance to the university. (The [Memorial Gates](#) were later built to mark this entrance, between 1927 and 1928). The location of St. Andrew’s College is a character-defining element due to its historical prominence (Figure 45).



Figure 44. 1928 aerial photograph. What may be the original St. Andrew’s foundations are circled in green. Photo A-184, retrieved from University of Saskatchewan Archives.

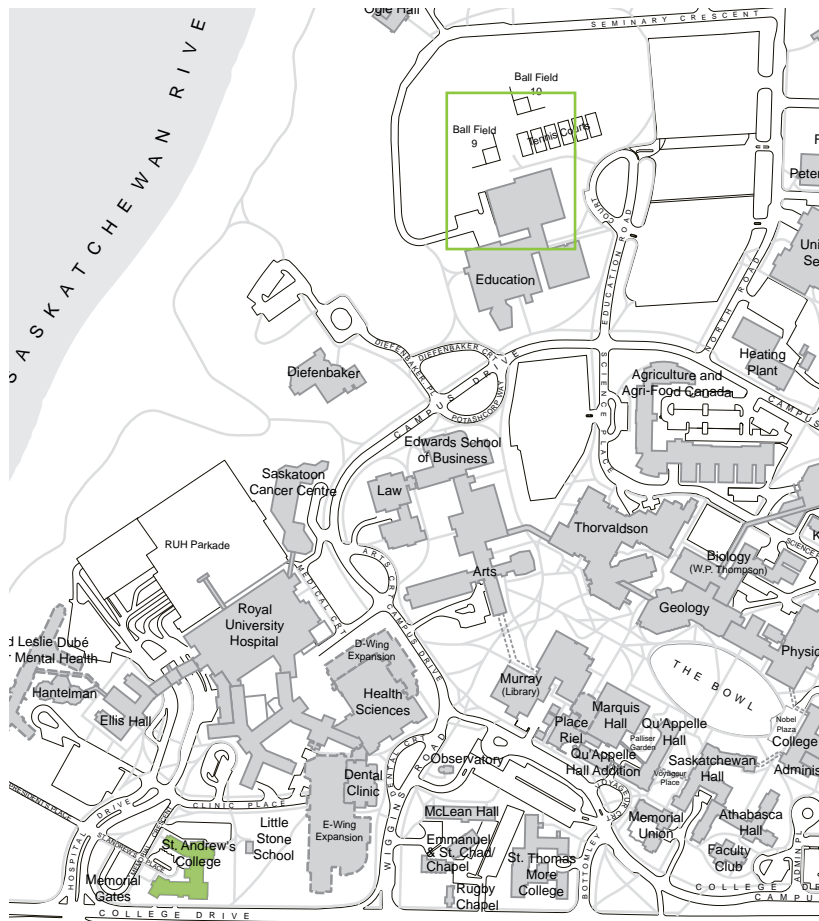

Figure 45. The 4.5 acre plot of land originally leased by the Presbyterian Theological College is outlined in green. The current location of St. Andrew's College is indicated in green on this contemporary campus map.

In the time between the founding of the Presbyterian College in 1912 and the completion of the building in 1923, the college operated from a house at 209 Albert Avenue. The house still exists, and still appears on the exterior much as it did in the early 20th century (Figures 46 & 47). (See also Section 2.8 - Cultural and Chronological Associations).



Figure 46. A 1923 photograph of the Presbyterian Theological College at 209 Albert Avenue. Photo A-2942, retrieved from University of Saskatchewan Archives.



Figure 47. 209 Albert Avenue at present. Retrieved from <http://maps.google.ca>.

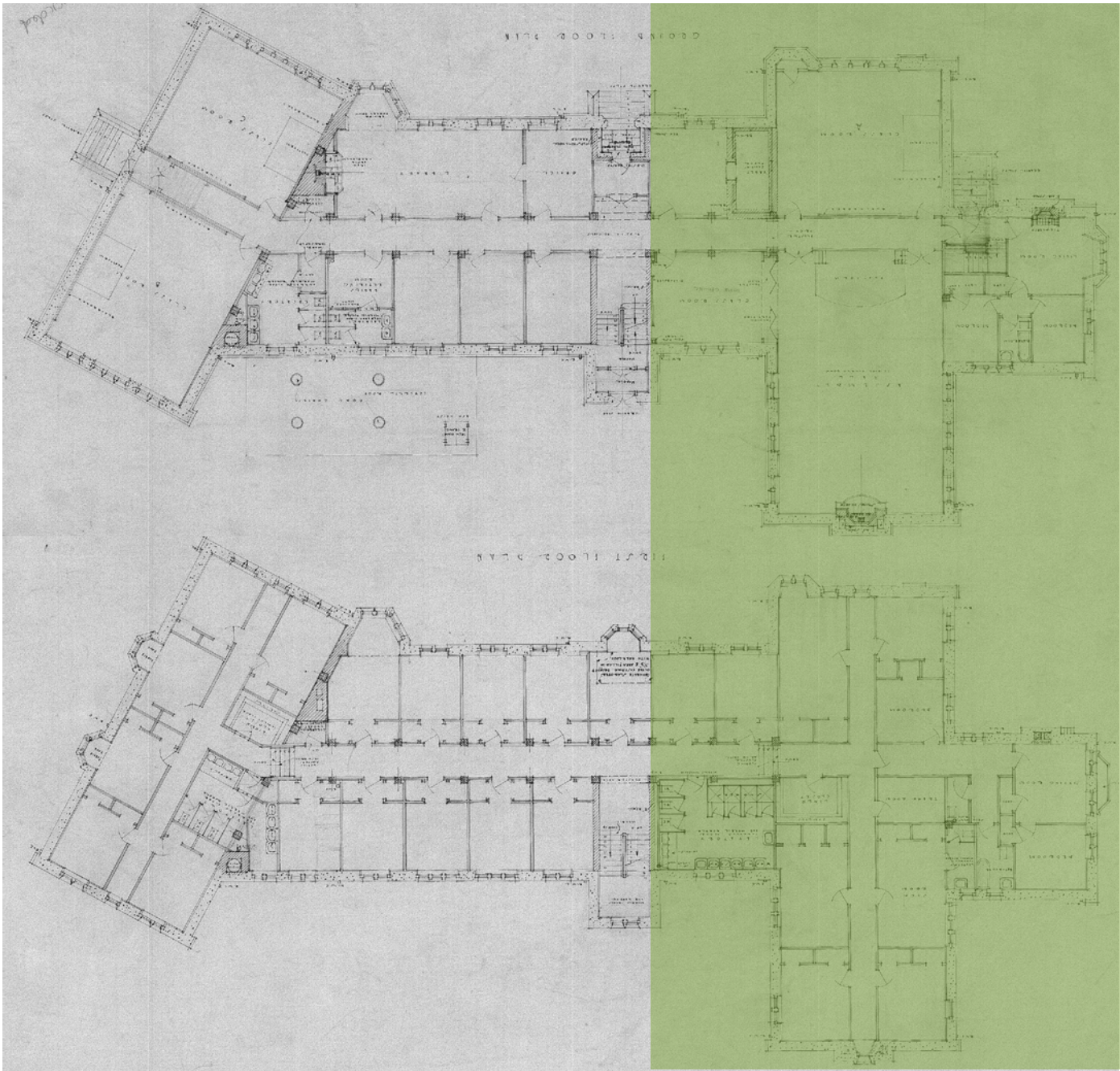

Figure 48. Top to bottom: preliminary ground and first floor plans of St. Andrew's College including many unrealized features. The areas shaded in green were never built, nor were the oriel windows. The rest of the plan is accurate. Retrieved from Facilities Management Asset Record System, File SC-93-P.



Figure 49. Ground floor fireplace. Photo retrieved from St. Andrew's Archives, File STA.J.21.10.1-43

2.5 Spatial Configuration

The spatial configuration of St. Andrew's College has been altered relatively little, and retains a high degree of heritage value. The building was built in two phases, the first beginning in 1922, the second in 1959. Notably, the initial structure was always anticipated to grow. Early plans show the 1922 building with an extra wing appended to its east side (Figure 48). However, this early proposed addition was not constructed; the 1959 addition was built to a new

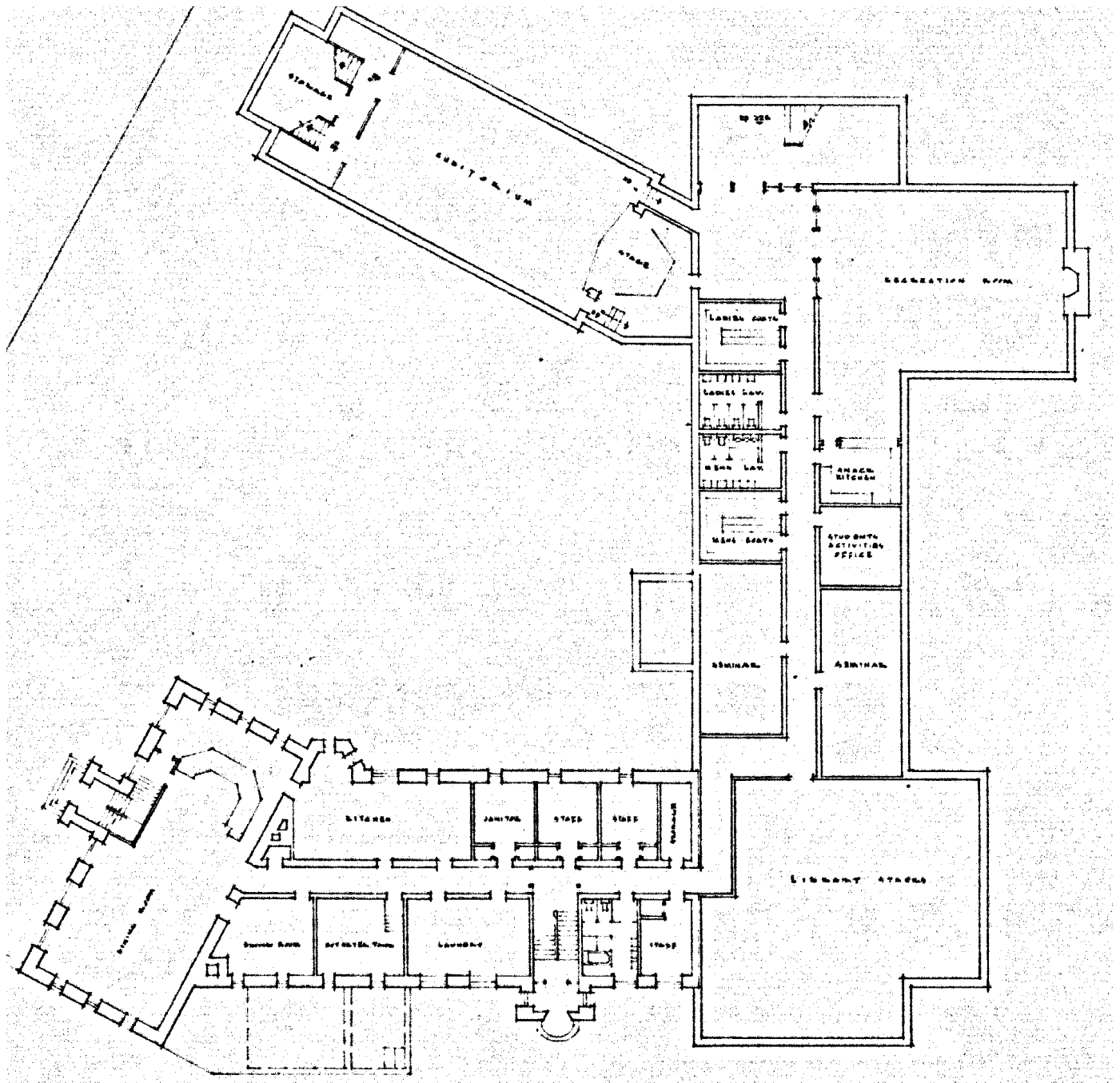

Figure 50. Basement floor plan of St. Andrew's College after completion. Retrieved from Asset Record System, File SC-41-T.

design by Webster, Forrester and Scott Architects.

In general terms, the building is laid out with its larger feature spaces – a chapel, a library, a student lounge and a classroom – located at the extremities of the plan and connected by a series of double loaded corridors, with smaller rooms arrayed on either side. The plan of the basement provides an indication of the typical arrangement (Figure 50). Subtle changes have occurred, for example, dormitory rooms have been converted to offices, but the general arrangement of spaces remains intact.

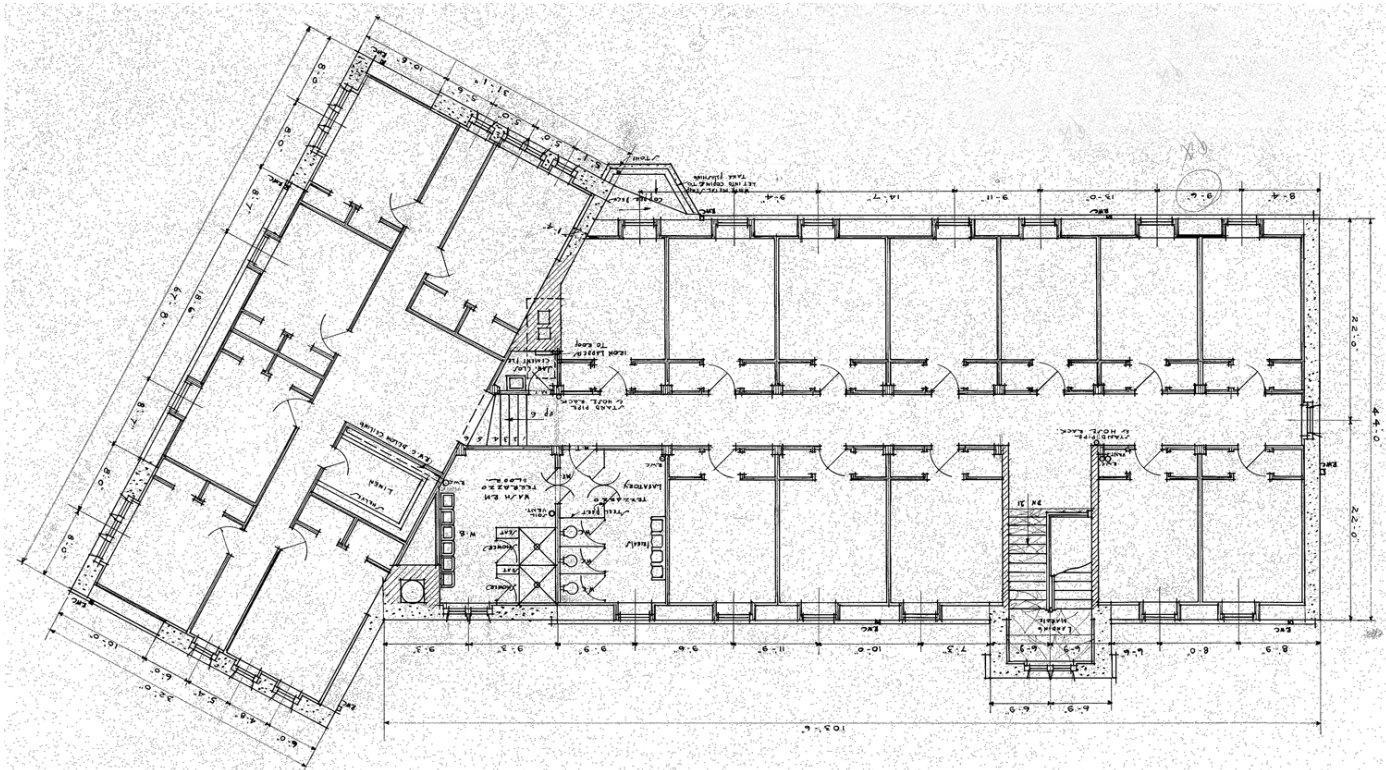

Figure 51. Attic plan of 1922 wing of St. Andrew's College. Retrieved from Facilities Management Division Asset Record System, File SC-14-T.



Figure 52. Chapel interior. Photo A-10767, retrieved from University of Saskatchewan Archives.

Some of the larger feature spaces merit special mention with respect to spatial configuration. The chapel adheres to gothic precedent as a high vaulted space with an open choir loft. Its east-facing nave is typical of Christian architecture and is character-defining. The orientation of the nave is determined by the configuration of the choir loft facing towards the stage at the east end of the chapel. Behind the low stage is the focal point of the room, a large stained glass window. The high vaulted ceiling of the chapel and the choir loft which faces the stained glass window and altar are character-defining elements. The spatial qualities of the chapel are visible in Figure 52.



Figure 53. A 1922 construction photo. Photo retrieved from St. Andrew's Archives, File STA.J.3.1.1-18.

Across from the chapel is a double-height student lounge, which occupies the basement and first floor. The lounge is bathed in daylight owing to the tall windows on its north and south walls. The eastern wall is occupied by a grand fireplace (Figure 39). A set of stairs to the west allow access to a mezzanine level overlooking the lounge. The mezzanine, high ceiling, large hearth and the windows of the student lounge are character-defining.

2.6 Systems

The 1922 and 1959 portions of the building differ in their structure. The exterior stone walls of the 1922 portion were built to be load-bearing. They are probably lined on the interior with hollow clay tile, although the original drawings do not show this detail. Concrete lintels span the window and door openings in the exterior walls. The exterior walls sit on cast-in-place concrete foundations and footings. The two interior corridor walls are constructed of load-bearing brick. Floors are cast-in-place concrete slabs on concrete joists. The roof is supported by a steel truss system which is concealed in the attic. Interior partition walls are constructed of clay tile. Terracotta tile was also used to fur down the ceiling in the attic. Figure 53 shows the construction of the exterior stone walls with a pile of clay tile visible.

The 1959 structural strategy differed greatly from that used in the early 1920's. The primary structural system is a steel frame, consisting of steel columns with open web steel floor joists supported on steel beams and girders. The exterior walls are a hybrid system; structural steel columns are embedded in cast-in-place concrete walls, which are faced on the exterior in greystone. The greystone exterior was used as formwork for the concrete. The photograph in Figure 54 shows the building under construction, with all the elements of this system clearly visible. The 1959 addition included the construction of a chapel, with a roof structure distinct from the rest of the building (Figure 40). The pitched roof is supported by a series of glue-laminated wooden scissor trusses and wooden purlins, with exposed wood decking exposed on its underside. The bottom chords of each truss take the form of a pointed arch, creating a vaulted space. The structure of the chapel is a character-defining element.

The 1922 wing of the building still contains its original cast iron radiators (Figure 10) and the original fire hose apparatus. Some of the fire hoses appear to still be in use (Figure 55). The radiators and fire hose system are character-defining elements for their material and aesthetic value.



Figure 54. A 1959 construction photo. Photo retrieved from St. Andrew's Archives, File STA.J.21.10.1-43



Figure 55. Fire hose apparatus.



Figure 56. A classroom in St. Andrew's College, pre-1946. Photo retrieved from St. Andrew's Archives, File STA.I.



Figure 57. Student leisure, pre-1946. Photo retrieved from St. Andrew's Archives, File STA.I.



Figure 58. Photograph of the dining room formerly located in the basement. Photo retrieved from St. Andrew's Archives, File STA.J.10.1.1-16.



Figure 59. A 1965 photograph of the kitchen formerly located in the basement. Photo retrieved from St. Andrew's Archives, File STA.I.24.1.1-9.



Figure 60. Photograph of the library formerly located on the ground floor of St. Andrew's College. Photo retrieved from St. Andrew's Archives, File STA.J.10.1.1-16.

2.7 Use(s)

St. Andrew's College was built to accommodate theological education, and is still used for this primary purpose. In 1911, President Murray wrote to architects David Brown and Hugh Vallance, asking them to prepare drawings for the first wing of the building. The building was to include residential accommodation for 40 students, a common room, kitchen, dining room, matrons' and servants' quarters and a trunk room in the attic. Figure 56 shows one of the classrooms being used for divinity training. A later addition was to include lecture rooms, a library, and possibly a gymnasium. Although the building was not started until 1922 and not completed until 1961 all of the uses specified by Murray were eventually provided (Figures 56-61).

Many of the rooms built to accommodate these early functions have since been put to other uses. The cafeteria was closed in the mid 1980's and is now used as a common room. The former pantry is now a staff lounge. The dormitory rooms are now used as offices. The kitchen is now used as a large classroom. The maids' quarters are now a meeting room and lounge space. One original classroom has been retained, but all the others have been converted into offices or meeting rooms. The library was also converted into office space although with the 1959 addition a new library space was added just down the hall. The chapel, student lounge and gymnasium built as part of the 1959 addition still exist, but the gymnasium is now used as a lab for the School of Physical Therapy. The third floor of the 1959 addition is still used as a student residence. The use of the building as a residential theological college is a character-defining element.

2.8 Cultural & Chronological Associations

Lydia Gruchy, a graduate of the Presbyterian Theological College, was the first woman in Canada ordained as a minister by the United Church. Gruchy was born in Paris and moved to Strassbourg, Saskatchewan with her family. Gruchy taught for a few years before receiving her Bachelor of Arts from the University of Saskatchewan in 1920. In 1923 she graduated from the Presbyterian Theological College. She applied for ordination in the newly formed United Church in 1926 and repeated her application annually until 1936 when the United Church approved women's ordination. She was ordained on November 4 of that year in St. Andrew's Church in Moose Jaw. In 1953, Gruchy also became the first Canadian woman to receive the Doctor of Divinity degree from St. Andrew's College. In 1994, two years after her death, the chapel at St. Andrew's Church in Moose Jaw was renamed the Lydia Gruchy Chapel in her honor.

Before the construction of the current St. Andrew's College building, the Presbyterian Theological College held classes in a large family home at 209 Albert Avenue. (See Section 2.4 - Location). The house on Albert Avenue still appears on the exterior much as it did in its 1923 photos. As the earliest home of the Presbyterian Theological College, 209 Albert Avenue can be associated with St. Andrew's College.

The cornerstone for the addition to the college was laid on September 13, 1960. The cornerstone is located in the courtyard, to the right of the west entrance. The cornerstone associates the building with the time of its construction and is a character-defining element.

The large stained glass window in the chapel depicts a man and a woman, praying on their knees in front of Jesus (Figure 42). Jesus is standing on top of the world, his arms outstretched. The banner across the bottom reads, 'And lo I am with you always, I have overcome the world. Go ye therefore and teach all nations.' The names of several academic disciplines surround the mural including education, science, medicine, politics, agriculture and industry. The stained glass window is an important character-defining element, connecting the educational and religious objectives of the college.



Figure 61. Residence rooms in the 1959 addition. Photo A-10755, retrieved from University of Saskatchewan Archives.



Figure 62. Cornerstone.



Figure 63. Graduand photo collection.



Figure 64. A plaque dedicating the 1959 addition as the 'Schnell Memorial wing.'

3. Associated Objects

A series of graduand photos hang on the walls of the 1959 wing of the building. The collection spans 7 decades, from 1923 through 1990. The early photographs date from the time the institution was known as the Presbyterian Theological College.

A plaque dated March 10, 1980 dedicated the newer portion of the building to Reverend Robert Ferdinand Schnell. Schnell was a professor at St. Andrew's College from 1943 until his death in 1978. He was Principal of the college between 1955 and 1971.

4. Supporting Documents

Author Unknown. (Retrieved 2012). *Our History - St. Andrew's College*. Retrieved from <http://www.usask.ca/stu/standrews/about-us/our-history.php>

Calhoun, P.J. (Retrieved 2012). *The Encyclopedia of Saskatchewan, Gruchy, Lydia E.* (1894-1992). Retrieved from http://esask.uregina.ca/entry/gruchy_lydia_e_1894-1992.html

Facilities Management Division (2012). Asset Resource Database [Data File]. Retrieved from \\usask\fmddfs\files\iis\IIS_Public\ARS.

Morton, A.S. (1934-1937). *Written in Letters of Gold: A. S. Morton's History of the University of Saskatchewan's First 25 Years*. Retrieved from http://library.usask.ca/archives/campus-history/pdfs/Essays2006_Morton.pdf

St. Andrew's Archives. STA. A. Miscellaneous Letters

St. Andrew's Archives. STA. I. Miscellanea.

University of Saskatchewan Archives. (Retrieved 2012). *Campus Buildings: St. Andrew's College*. Retrieved from http://scaa.sk.ca/gallery/uofs_buildings/

5. Summary of Character - Defining Elements

Materials

- greystone walls and fireplace
- granite base, steps and hearth
- Indiana limestone trim and decoration
- Indiana limestone mantelpiece and crest
- copper ridges, flashing and downspouts
- slate roofing
- bronze or brass window and door hardware
- maple floors
- oak doors and wainscoting
- terrazzo stair treads and landings
- glazed tile wainscoting
- marble stair treads and wainscoting
- steel stair stringer and balustrade
- oak banister
- cast iron newel post
- stained glass windows

Form

- scale
- arrival court

Style

- gothic arch transoms and windows
- gabled roofs
- dormer windows
- stone walls
- stone string courses
- stone buttresses on the chapel
- quoins
- cut stone crests and arches
- bay windows
- false balcony
- arches

Location

- present site chosen in 1922
- 209 Albert Avenue

Spatial Configuration

- double-loaded corridors
- formation of courtyard
- double-height student lounge
- chapel vault, choir loft and stage
- east facing nave in chapel
- high ceilings and windows of





Systems

- first floor classroom
- steps to west wing

Uses

- stone buttresses on chapel
- glue-laminated arches
- Theological residential college
- student lounge
- auditorium
- chapel

Cultural & Chronological Associations

- Presbyterian Theological College
- 209 Albert Avenue
- Lydia Gruchy, first woman ordained by the United Church
- cornerstone

933

Rugby Chapel



933

Rugby Chapel

Alternate Names

Emmanuel Chapel
English Church
Multi-Faith Centre

Designer

Oluf Albrechtson

Builders

Students of Emmanuel College
Local Tradesmen

Construction Dates

Originally constructed in Prince Albert, 1911
Moved to Saskatoon and expanded, 1913

Recognition

Municipal Heritage Property, Designated April 13, 1987
University of Saskatchewan 'A' Listed



Figure 1. The wooden interior of the Rugby Chapel.

1. Statement of Significance

The heritage value of the Rugby Chapel is based on its associations with the history of Anglican education in Saskatchewan, and its historical ties to the University of Saskatchewan. Constructed in Prince Albert in 1911, it was moved to Saskatoon in 1913 and became the first permanent Anglican place of worship built on the campus of the nascent University of Saskatchewan. Built with funds raised by students at Rugby School in England, the chapel has served the needs of the Anglican community on campus for 54 years, gradually becoming a repository for religious artifacts associated with the Anglican tradition in Saskatchewan.



Figure 2. Rugby Chapel from the north-east.

The architecture of the chapel, which has survived virtually intact, also gives this building significant heritage value. It was built in a hybrid style blending Gothic Revival with the typical residential wood-framed construction details of its time and place. It is one of the few remaining Anglican places of worship in Saskatoon that is constructed of wood and one of last remaining wooden buildings on the grounds of the University of Saskatchewan.

2. Character - Defining Elements

2.1 Materials

As a wooden building on a predominantly stone campus, Rugby Chapel distinguishes itself from its surroundings. Both the interior and exterior, shown in Figures 1 and 2, are finished in wood. Wood-framed stained glass windows (Figure 3) punctuate the building's façade and bring light into the nave and transept. The larger and more intricate stained glass of the Memorial Window is built as a steel-framed insert within a wooden framed opening. Inside the building, wooden roof trusses, ceilings and wainscoting create a continuous wooden interior. The original hardwood floors have been covered in carpet. The sanctuary features wooden wainscoting with plaster walls and ceiling (Figure 4). Fixtures and furnishings such as the pulpit and pews shown in Figure 5, the sanctuary balustrade and the altar are also wooden. The wood is in good commemorative condition save for some water damage that took place in 2012 causing some staining and warping.



Figure 3. Wood-framed stained glass windows.



Figure 4. The sanctuary framed by a gothic arch.

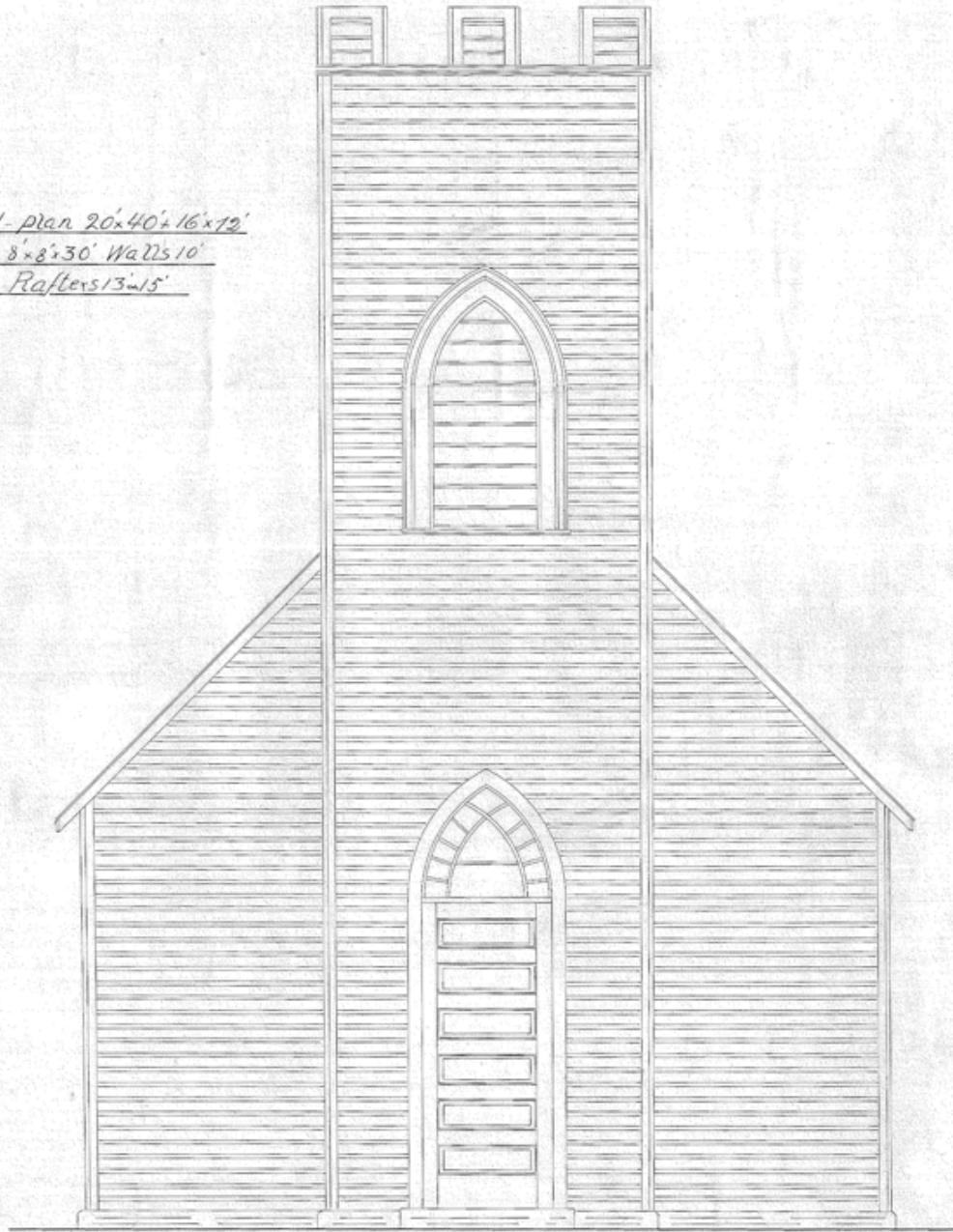

Figure 5. L to R: oak pulpit and pews.

English Church

Front Elevation

Ground-plan 20'x40'x16'x19'
Tower 8'x8'x30' Walls 10'
Rafters 13'-15'



Scale 2 Feet to an inch

Old Abbeville
Prince Albert
Sask

Figure 6. The front elevation of Rugby Chapel. Comparison with Figure 2 shows that the tower was not built as shown. Retrieved from Facilities Management Division Asset Record System, File EC-105-P.

2.2 Form & Style

A cruciform layout typical of mediaeval English churches characterizes the form of the one story Rugby Chapel. The nave and sanctuary align north to south and are bisected by the east-west transept. A 30 foot tall 'Norman' tower, shown in Figure 6, signals the entrance to the building on the north side.

With its gothic windows, vaulted ceiling and 'Norman' tower, Rugby chapel can be classified as a building in the Gothic Revival style. Elements characteristic of this style are the tower with its crenellated parapet (Figure 6), and the pointed arch windows featuring tracery, shown in Figure 7. However, these traditions of the English stone-built churches of the Middle Ages are rendered in the wood-framed structure and painted cedar lap siding typical of residential construction in Western Canada at that time.

The tracery in the windows forms a pattern of multiple gothic arches. Openings in the shape of a pointed arch also frame the entrances to both the vestibule and the altar. One of these openings is seen in Figure 4, framing the sanctuary. The bell tower features pointed arched openings and crenellations. These character-defining elements are visible in Figure 2.

The ceiling is not a true vault; however, its height and geometry create a similar effect, and is a character-defining element. Figure 8 illustrates the 'crossing', where the ceilings and exposed roof trusses of the nave and transept meet to create an effect similar to a groin vault. The rendering of traditional masonry architectural elements in wood is a distinctive feature of this building.

2.3 Location

The location of Rugby Chapel, part of a cluster of buildings associated with the [College of Emmanuel and St. Chad](#), is

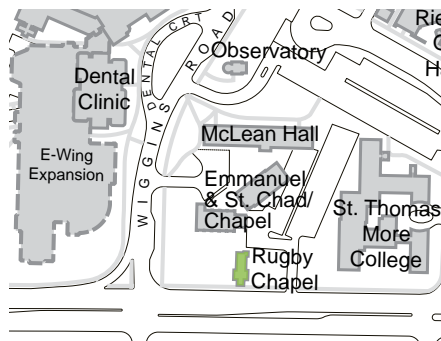

Figure 9. The Rugby Chapel is indicated in green on this contemporary campus map.

significant, reflecting its importance to the Anglican College. Its location on the main campus of the University of Saskatchewan, shown in Figure 9, also associates Anglican education with the university.

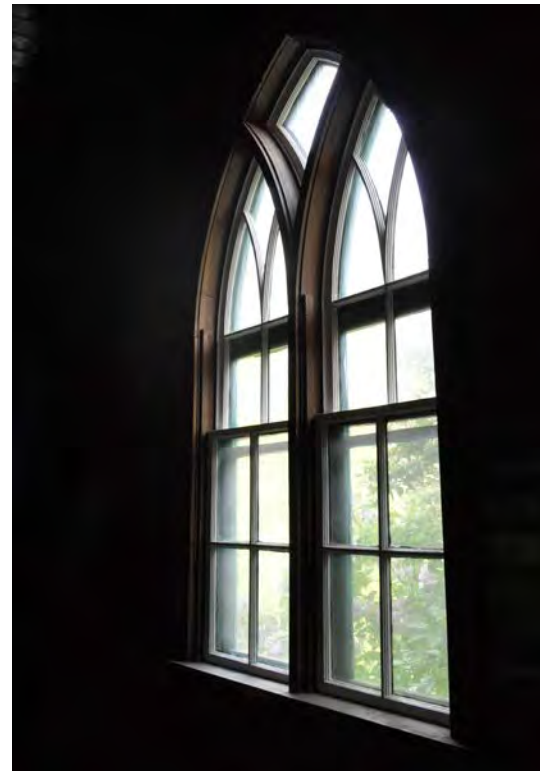

Figure 7. Pointed arch windows. The tracery is also in the shape of pointed arches.

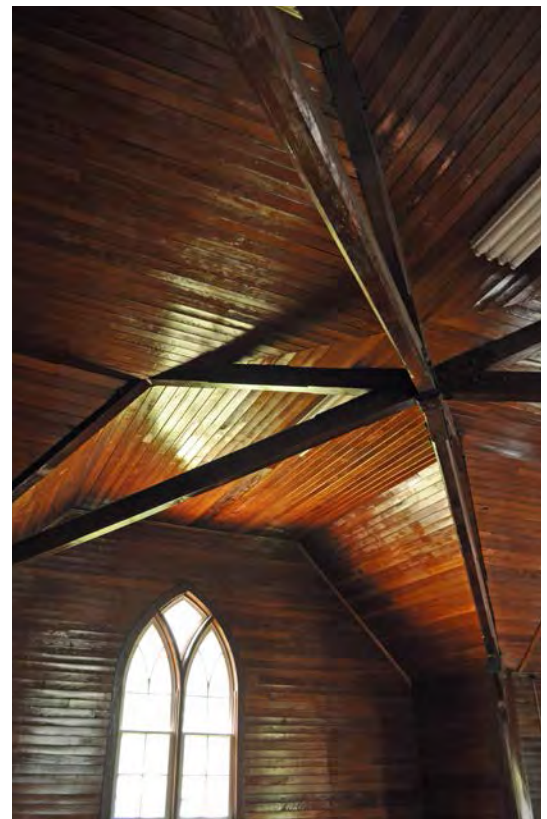

Figure 8. The ceiling is shaped to create a vault and dome effect on the church interior.



Figure 11. Fluorescent lighting has been added.



Figure 12. 1912. Rugby Chapel after its move to the University of Saskatchewan with the chancel cut off. Emmanuel College is visible to the left. Photo A-332, retrieved from <http://sain.scaa.sk.ca/items/index.php/emmanuel-college-rugby-chapel;rad>



Figure 13. Concrete foundation walls and a wooden post and beam system.

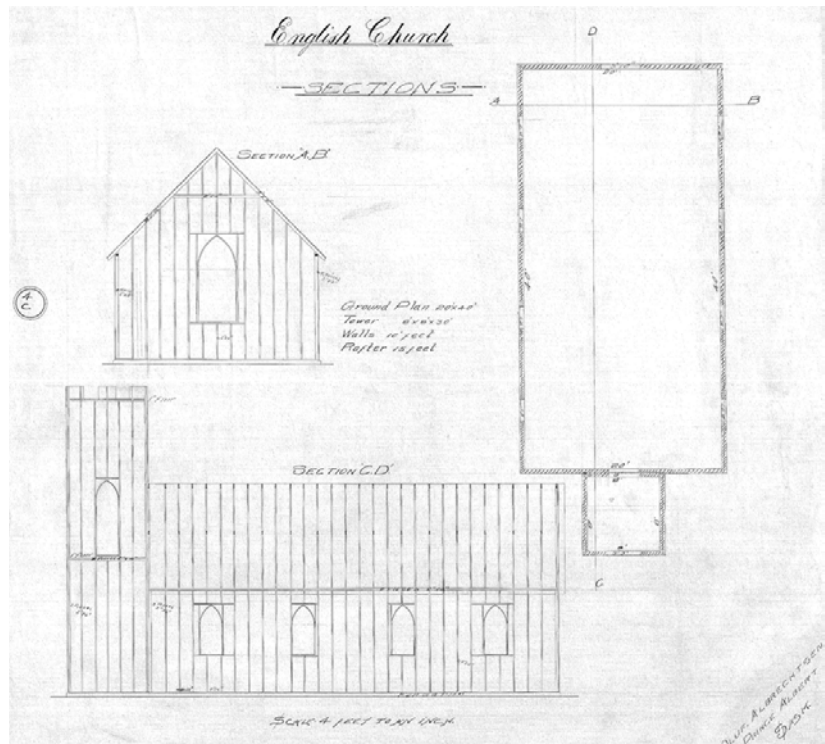

Figure 10. The original floor plan. Additions have made it cruciform in shape. Its layout has remained open. Retrieved from Facilities Management Division Asset Record System File, EC-112-T.

2.4 Spatial Configuration

Although limited in area, the chapel is made to seem spacious by virtue of a high ceiling (Figure 8) and an open floor plan. The walls of the chapel measure 10 feet in height and the exposed roof trusses are 15 feet above the floor. The only doors in the building are located in the vestibule. Figure 10 shows the floor plan of the church as it existed prior to its expansion. The open floor plan has been fully maintained. The interior is lit naturally by daylight. Fluorescent lighting has been added, although it is rarely required during daylight hours (Figure 11).

The current configuration of the chapel is the result of an addition carried out when the building was moved from Prince Albert to Saskatoon in 1913. At that time, the chapel was expanded to seat 200 people rather than 150. The ceiling was raised and the walls decorated in 1922. Also in 1922, a furnace replaced the three heating stoves that had previously served the church. The stained glass 'Memorial Window' (Figure 14), commemorating veterans of the First World War, was added in 1926.

2.5 Systems

Framed in wood, Rugby Chapel is one of a small number of buildings on campus that feature this type of structure. The roof of the chapel is supported by a series of partially exposed wooden trusses (Figures 8 & 11). Carved wooden brackets support each truss where they meet the exterior walls. Steel tension rods anchored behind these brackets form the bottom chord of each truss. These exposed trusses are important character-defining elements. Figure 12 illustrates the reconstruction of Rugby Chapel on the current University of Saskatchewan site shortly after being moved from Prince Albert.

The Rugby Chapel has a basement, with concrete foundation walls and a central beam with wooden posts supporting the ground floor at its midspan. These elements are visible in the basement as shown in Figure 13.

2.6 Uses

Rugby Chapel was historically used as the main chapel of Emmanuel College (now the College of Emmanuel and St. Chad). As such it carried out many religious functions. Benediction, dedication and dismissal services were held here. Special services held under the auspices of the Student Christian Movement were held in Rugby Chapel from time to time. The chapel was also used for annual events that came to characterize the cycle of its life. In the spring time students from the nearby residences went to Rugby Chapel for 'Evensong.' It was university custom to hold Christmas carol services here before the students left for winter vacation.

In 1966 its role was reduced when the new [Emmanuel Chapel](#) was built. Since this time it has seen varied religious and educational uses. It is currently used as a multi-faith centre, such that its religious use has been maintained in a new capacity.



Figure 17. The 'Book of Remembrance' is mounted on the Western wall of the sanctuary. It holds the names of the men who gave their lives in the First World War.

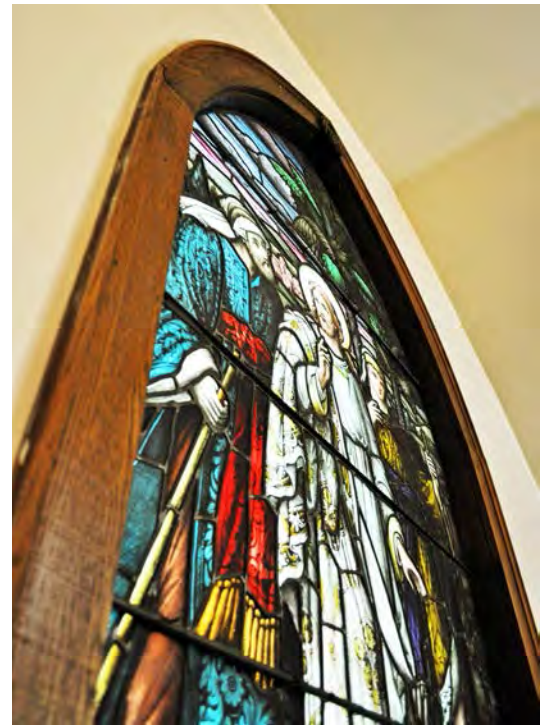

Figure 14. The Memorial Window, 'Jesus' Walk to Emmaus,' installed in 1926 in honor of those who gave their lives in WWI.



Figure 15. The words 'Emmanuel' in gilded letters at the head of the sanctuary.



Figure 16. The nine men of Emmanuel College killed during the First World War are commemorated by the Memorial Window.

2.7 Cultural & Chronological Associations

Rugby Chapel is named for Rugby School in England, a boys' school which raised the funds for its construction. Rugby Chapel draws a great deal of its heritage value from its association with Anglican education in Saskatchewan and at the University of Saskatchewan. The chapel is an important building in western Canadian theological history.

Rugby Chapel is strongly associated with [Emmanuel College](#) as the building was constructed for the use of the College. The dedication ceremony for Emmanuel College's first graduating class was held in the chapel. Figure 15 shows a mantelpiece below the Memorial Window with the word 'emmanuel' carved in gilded letters, commemorating this association.

Also important in Anglican history was the work of a student of Emmanuel College, the Reverend Herbert Girling. Girling's dismissal service as first missionary to the Inuit of Coronation Gulf was held in Rugby Chapel. Subsequently, the theologian went on to translate scripture into the Inuinnaqtun language, the language traditionally spoken in the region, before his premature death.

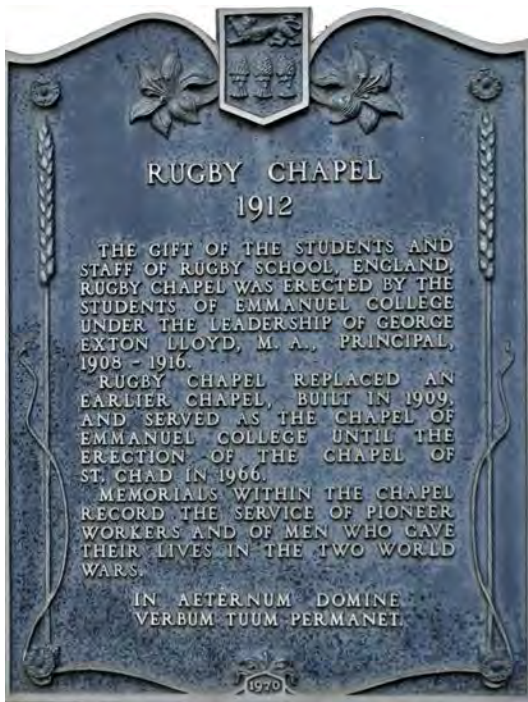

Figure 18. Top to Bottom: a plaque describing the history of Rugby Chapel, a plaque presented to Emmanuel College in memory of E. Gerard Birl, a plaque in memory of the Emmanuel College men who gave their lives during the First World War.



Figure 19. Top to Bottom: Plaques honoring James and Margaret Brown, Emmanuel College men who gave their lives in the First and Second World Wars, John Alexander MacKay a principal of Emmanuel College and the Reverend Canon Robert Malcolm Millman.

Ceremonies held in the chapel also chronicle contemporary historical events. Benediction ceremonies for soldiers going overseas in the First World War were held in Rugby Chapel. The chapel was closed for a period of time during the war and reopened in 1922. The chapel relates these events through a 'Memorial Window' bearing the names of nine Emmanuel College men who gave their lives. These names are shown in Figure 16. The Memorial Window depicts Jesus' walk to Emmaus with his disciples.

3. Associated Objects

A 'Book of Remembrance', (Figure 17), lists the men lost to Emmanuel in the First World War. Several plaques honor those associated with the building or Emmanuel College who gave their lives in the two world wars. These plaques are shown in Figures 18 and 19. A brass lectern (Figure 20) is dedicated to the memory of Herbert Girling. Several items associated with the religious function of Rugby Chapel still exist in the church.



Figure 20. Brass Lectern dedicated to the efforts of Herbert Girling.

The original pipe organ no longer exists; however, the chapel contains two organs and a piano. Although not original to the church, the older of the two organs has candleholders which suggest its advanced age (Figure 21). Several oak church pews are still arranged in the transept. Figure 22 shows the pews with their pointed arch bases. The oak altar, also intricately carved with trefoil gothic arches, still holds its place in the sanctuary (Figure 23).



Figure 21. The older of two organs.

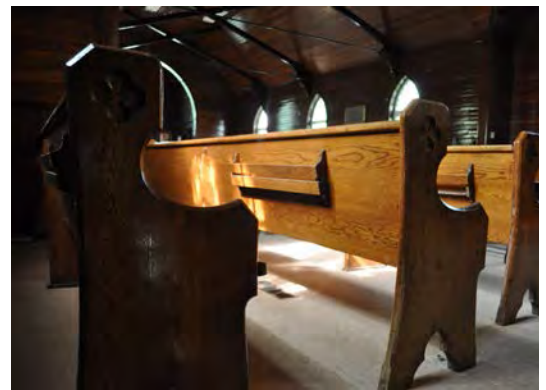

Figure 22. The Chapel's pews have pointed arches carved to form their feet and carved ornamentation on the exterior of the armrests.



Figure 23. The altar is carved with openings in the form of a trefoil pointed arch.

4. Supporting Documents

Anonymous. (2011, May 23). *Rugby Chapel*. Retrieved from http://en.wikipedia.org/wiki/Rugby_Chapel.

Author Unknown. (1929, June 13). Rugby Chapel. *The Canadian Churchman*, pp. 387.

Facilities Management Division (2011). Asset Resource Database [Data File]. Retrieved from \\usask\fmddfs\files\iis\IIS_Public\ARS

Mitsui, E. (2012, August 24). Life in the arctic: Where old ways and new collide. *CBC News*. Retrieved from <http://www.cbc.ca/news/canada/story/2012/08/23/f-arctic-cambridge-bay-life.html>

Parks Canada. (Retrieved 2011). *Rugby Chapel*. Retrieved from <http://www.historicplaces.ca/en/rep-reg/place-lieu.aspx?id=4994&pid=0>

Saskatoon Heritage Society. (Retrieved 2011). *Designated Buildings: Rugby chapel*. Retrieved from http://www.saskatoonheritage.ca/designated/rubgy_chapel.html.

University of Saskatchewan Archives. (Retrieved 2011). *Campus Buildings: Rugby Chapel*. Retrieved from http://scaa.sk.ca/gallery/uofs_buildings/.



5. Summary of Character - Defining Elements

Materials

- wooden trusses, wall panelling, ceiling panelling, exterior cladding
- stained glass windows
- plaster walls & ceilings

Form & Style

- cruciform shape
- north-south nave and sanctuary
- east-west transept
- norman tower
- vaulted ceiling
- Gothic Revival style
- parapet
- crenellations
- light wood-frame construction
- tracery
- gothic arches
- ceiling crossing
- use of traditionally masonry elements rendered in wood

Location

- clustered with other Emmanuel College Buildings
- University of Saskatchewan

Spatial Configuration

- high ceiling
- open floor plan
- natural lighting

Systems

- partially exposed wooden trusses, with carved wooden brackets and steel tension rods

Uses

- main chapel of Emmanuel College
- benedictions, dedications, dismissals

Cultural & Chronological Associations

- Rugby School, England
- Emmanuel College
- Herbert Girling (bronze or brass lectern)
- First & Second World Wars (memorial window and book of remembrance)

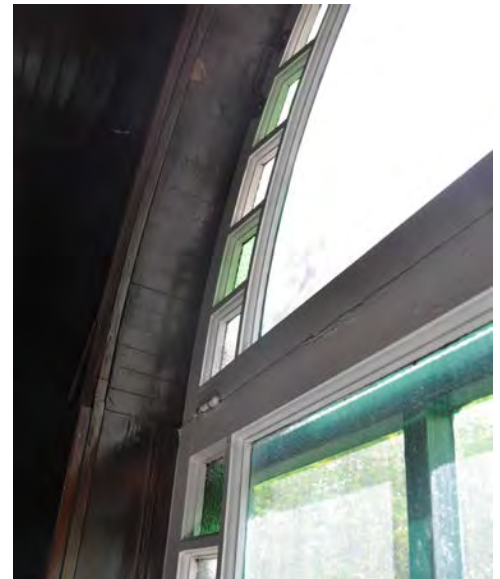

934

St. Thomas More College

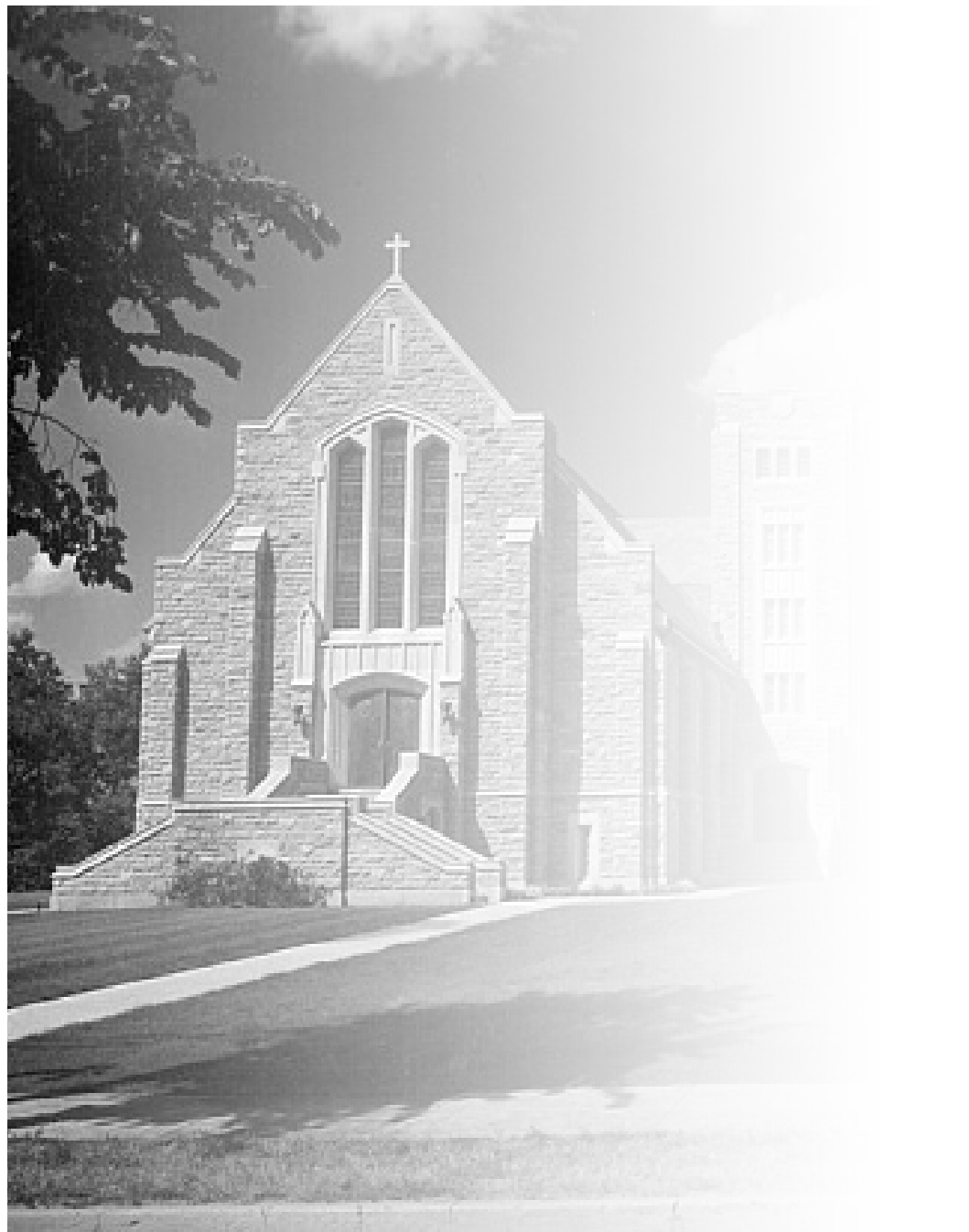

934

St. Thomas More College

Alternate Names

STM

Architect(s)

1954 - Webster & Gilbert Architects, Saskatoon

1963 - Peter Thornton, Gardiner, Thornton, Gathe & Associates, Vancouver

1969 - Peter Thornton, Gardiner, Thornton, Gathe & Associates, Vancouver with Gordon Arnott of Regina as associate architect

Builders

1954 - Shannon Brothers

1963 - Piggott Construction Co.

1969 - W.C. Wells Construction Co.

Construction Dates

1954-1956, 1963, 1969

Recognition

Federated College - 'B' Listing Recommended

1. Statement of Significance

St. Thomas More College (STM) is the only federated college at the University of Saskatchewan. Its first home was a wood-framed building called Newman Hall, also known as the 'white house', built at the corner of College Drive and Bottomley Avenue in 1927. In 1954 construction began on a 'greystone' building on the same site, and the original building was eventually demolished. The sod was turned for the construction of the St. Thomas More College building on Easter Sunday, April 18, 1954. The building cost \$600,000 to build, and opened on February 7, 1957. Additions to the building were carried out in 1963 and 1969. In 2013, another addition began construction, but this

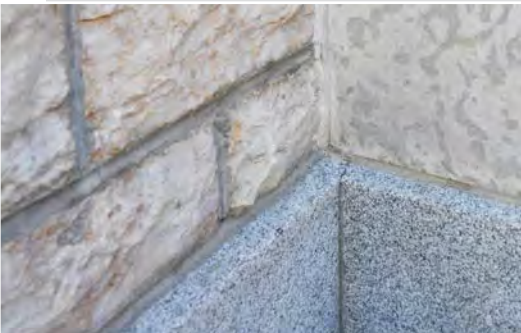

Figure 1. Greystone, Tyndall stone and granite base.

most recent addition is beyond the scope of this report. The first portion of the stone building was designed by Webster and Gilbert of Saskatoon. Peter Thornton of Vancouver designed the larger interior spaces. Thornton also designed the second addition with Gordon Arnott of the Regina firm Izumi, Arnott and Sugiyama Architects acting as associate architects. The 1969 addition was designed and built under the same arrangement. St. Thomas More College is of architectural historical interest as one of the last Collegiate Gothic buildings constructed at the university, in the case of the 1954-57 portion, and as an example of contextual Modernism in the two later additions. By the 1950's, historicist architectural styles had generally been eclipsed by Modernism, so the Collegiate Gothic portions of the building are somewhat anachronistic.

Note: The St. Thomas More College Building is configured with floors numbered Basement, First Floor, Second Floor and Third Floor. This report follows the same convention.



Figure 5. St. Thomas More College, 1954. Photo A-774, retrieved from University of Saskatchewan Archives.

2. Character - Defining Elements

2.1 Materials

The exterior of STM is constructed of 'greystone' walls, with cut Tyndall stone trim, on a granite base course (Figure 1). The greystone, a stone native to the South Saskatchewan River valley, defines much of the campus, and was a choice of materials intended to associate St. Thomas More College with the larger university. (For further information on the stone materials used in this building, refer to [Appendix: Stone.](#)) Other exterior materials include slate tile roofing, copper downspouts, and steel exterior light fixtures (Figures 2 & 3). The oldest parts



Figure 2. Slate tile roofing.

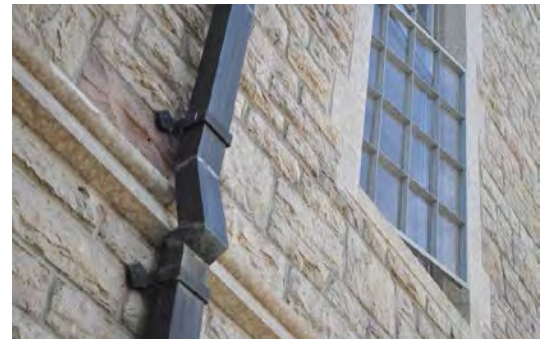

Figure 3. Copper downspout and painted steel window sash.



Figure 4. Aluminum framed windows set into a field of greystone.



Figure 6. Copper doors set into oak panelled walls.

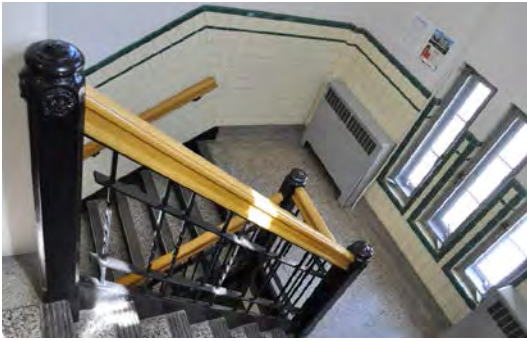

Figure 7. Character-defining stairwell materials.



Figure 8. Glazed ceramic tile wainscoting, oak banister, steel stair and terrazzo treads.



Figure 9. Red clay tile flooring.

of the building have painted steel sash windows with multiple divisions (Figure 3). The newer portions of the building have aluminum framed glazing (Figure 4). In these cases the glazing is not divided into smaller lites, but rather larger panes of glass are used. The original exterior materials are character-defining elements.

The interior of the 1954 section of the building has retained most of its original character-defining materials. Four sets of copper doors were a gift of the Emmett Hall family and were designed and constructed by the Vancouver artist, Lionel Thomas. The doors are fabricated from kiln-dried fir and covered with sheets of copper. The copper doors feature various designs including the crests of St. Thomas More and John Henry Newman (Figure 6).

In the 1954 wing, the main stair has an oak banister and painted steel balustrade (Figure 7). The steel newel posts feature the flower motif found commonly in other early University of Saskatchewan buildings. Terrazzo treads have been retained on the upper floors and landings. Glazed ceramic tile wainscoting is used on the upper portion of the staircase (Figure 8). Oak wainscoting has been applied to many of the walls in the 1954 wing, but is not original to the building. Recent renovation work has shown that in at least some places, the original glazed tile wainscoting exists beneath the oak paneling. Original red terra cotta tile flooring has also been exposed in the original 1954 building (Figure 9). The corridors of the upper floors still have their original maple doors with stainless steel fixtures (Figure 11). Some of the brass door numbers remain.



Figure 10. Patterned concrete tile.



Figure 11. Maple door with brass numbers.

The chapel has walls of white plaster contrasted with exposed glue-laminated wood arches, and cedar paneling (Figures 15 & 30). The ceiling is also finished in cedar paneling (Figure 15). Stained glass windows, designed by Robert Rambusch of New York, are the focal point of the south wall. Vancouver artist Lionel Thomas was commissioned to design a mural, painted on oak panels, in the cantilevered recess at the north end of the chapel. The same artist designed the black granite altar. The black granite of the altar is sandblasted to give it texture and several wall mounted fixtures are made of the same material. The pews in the chapel are made of a light stained oak (Figure 14). The floors of the chapel are finished in black slate flagstones (Figure 14).

The interiors of the 1963 addition are modernist in character, with an emphasis on the use of cedar and oak. Doors are either cedar or quarter sawn oak. Cedar paneling makes up the ceiling of the library and lecture room. Oak millwork is found throughout; quarter sawn oak surrounds the entrance to the library. A grille made of walnut is featured above the doors. The oak paneling of the hallway art gallery is still in place, but has been painted. In the cafeteria, windows are set into deep quarter sawn oak surrounds. Each window is accompanied by a painted steel radiator. Exposed concrete columns with an exposed aggregate finish characterize the cafeteria. The 1963 addition also saw the

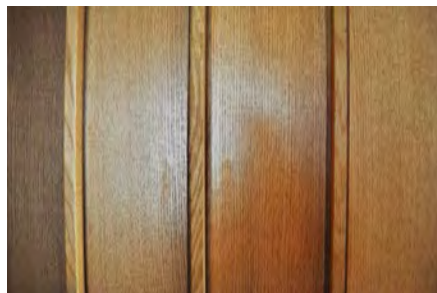

Figure 16. Oak wall paneling in the Chelsea Commons.

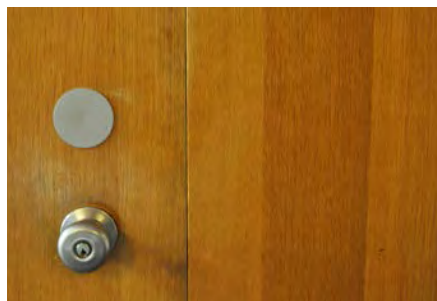

Figure 17. Oak door and wall panel with rabbitted frame and stainless steel knob.

installation of one more set of doors by artist Lionel Thomas. The northern entrance still features a set of multicolored ceramic and copper clad doors by the artist. Red tile makes up the underside of the accompanying arch.

The treatment of the materials in 1969 addition is characteristic of the Modern architectural style. This portion of the building features corridors with floor to ceiling panels of alternating oak and glass. The oak and glass are made to look uninterrupted and continuous; no transition materials or frames were specified. Oak baseboards are installed flush with the adjacent wall. Door jambs are rabbeted so as make the

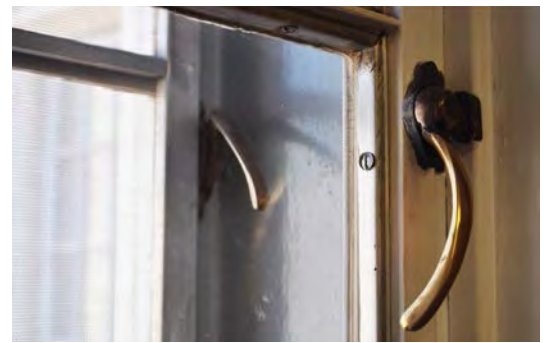

Figure 12. Brass window fixtures.



Figure 13. Aluminum window frame and steel handle.



Figure 14. Black slate flooring, oak pews.

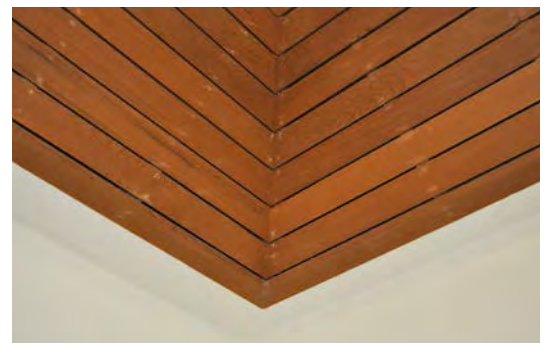

Figure 15. Cedar paneling on ceiling.



Figure 18. The progression of the building's form from 1956 - 1969. The uppermost figure features a photo of the stone STM College building shortly after its construction ca. 1956. The second photo displays an architectural model of the first expansion in 1963. The last photo shows a 1969 model of the third phase of construction. Photos B.07, A.29 and A.48, retrieved from St. Thomas More College Archives.



Figure 19. Tyndall stone corbels and string courses.

surface of the wall continuous (Figure 17). Throughout, materials are characterized by a lack of embellishment. The lecture room in the 1969 addition features the cedar panel roof, oak doors and window surrounds found in earlier portions of the building. The student lounge features a terrazzo floor. A greystone wall, formerly on the exterior of the building, has been enclosed as an interior element in the lounge space.

The original interior finish materials and the built-in artwork of the building are character-defining elements. The treatment of materials in support of the Collegiate Gothic and Modern architectural styles is also character-defining.

2.2 Form & Style

The exterior of the 1954 portion of the building is Collegiate Gothic in its style, although the expression of the style, particularly in the design of the chapel, is restrained and simplified in comparison to earlier examples. The front elevation of the chapel places an emphasis on its vertical elements, with its slender buttresses and tall, narrow lancet windows with stained glass. The doors to the chapel are clad in copper and set into an arched opening. The west elevation has an almost Modern expression of a series of cantilevered stone bays. The rest of the 1954 wing is more conventional, featuring typical Collegiate Gothic elements. A 'Norman' tower rises to the east of the chapel, and marks the main entrance. The roof is gabled, with a flattened top, and peaked dormer windows. The walls are in rough-faced greystone, with Tyndall stone string courses, windows surrounds, quoins and archer slots (Figures 21 & 22).



Figure 20. Arched door.

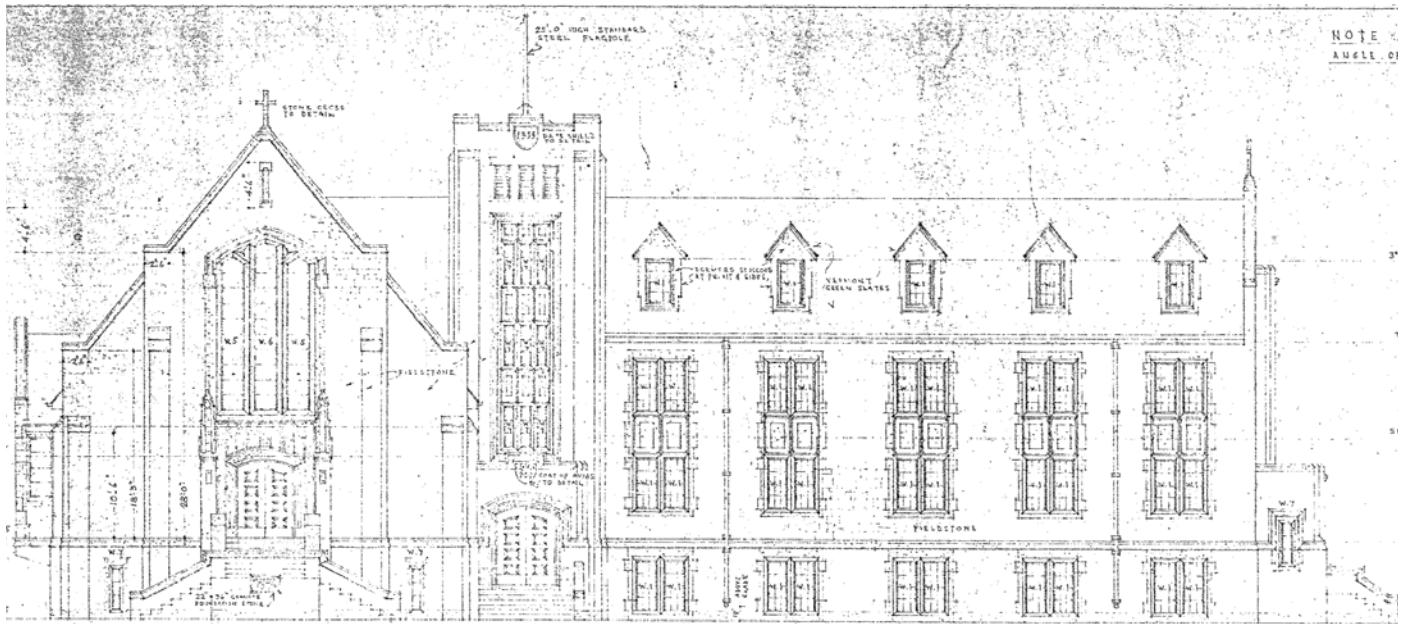

Figure 21. South elevation of the 1954 portion of the STM building depicting numerous character-defining elements of the Collegiate Gothic style. Retrieved from Facilities Management Division Asset Record system, File 934-241-T.

The 1963 and 1969 additions are Modern in style. The form of these portions is low, at mostly two stories in height, and relatively widely spread. In some instances its roofs are flat, and where pitched slate roofs are employed, they are set back from the exterior walls, behind the parapets, emphasizing the horizontal roof-line. The expression of the stonework differs significantly on the original building and its later additions. On the original portions of the building, stone is employed traditionally, with rough-faced greystone the predominant material and Tyndall stone used for window surrounds and cut stone details. However, on the 1960's additions, the greystone is expressed as a panel, interrupted by horizontal bands of smooth-faced



Figure 22. Tyndall stone quoins and arched slots adorn a peaked parapet.

Tyndall stone (Figure 24). Vertical windows separate the greystone panels. The northern stair tower is detailed in a modernist way, as a series of slender Tyndal stone columns separated by narrow windows stretched over the full height of the tower (Figure 27). The 1969 addition follows the same principles and is largely indiscernible from the 1963 portion.



Figure 23. Lancet windows set into a gothic arch formed in stone. Stone piers and references to statuary niches flank the arched entry.



Figure 24. Typical arrangement of windows on the modern portions of the building.



Figure 25. Narrow windows make reference to historical archer slots.

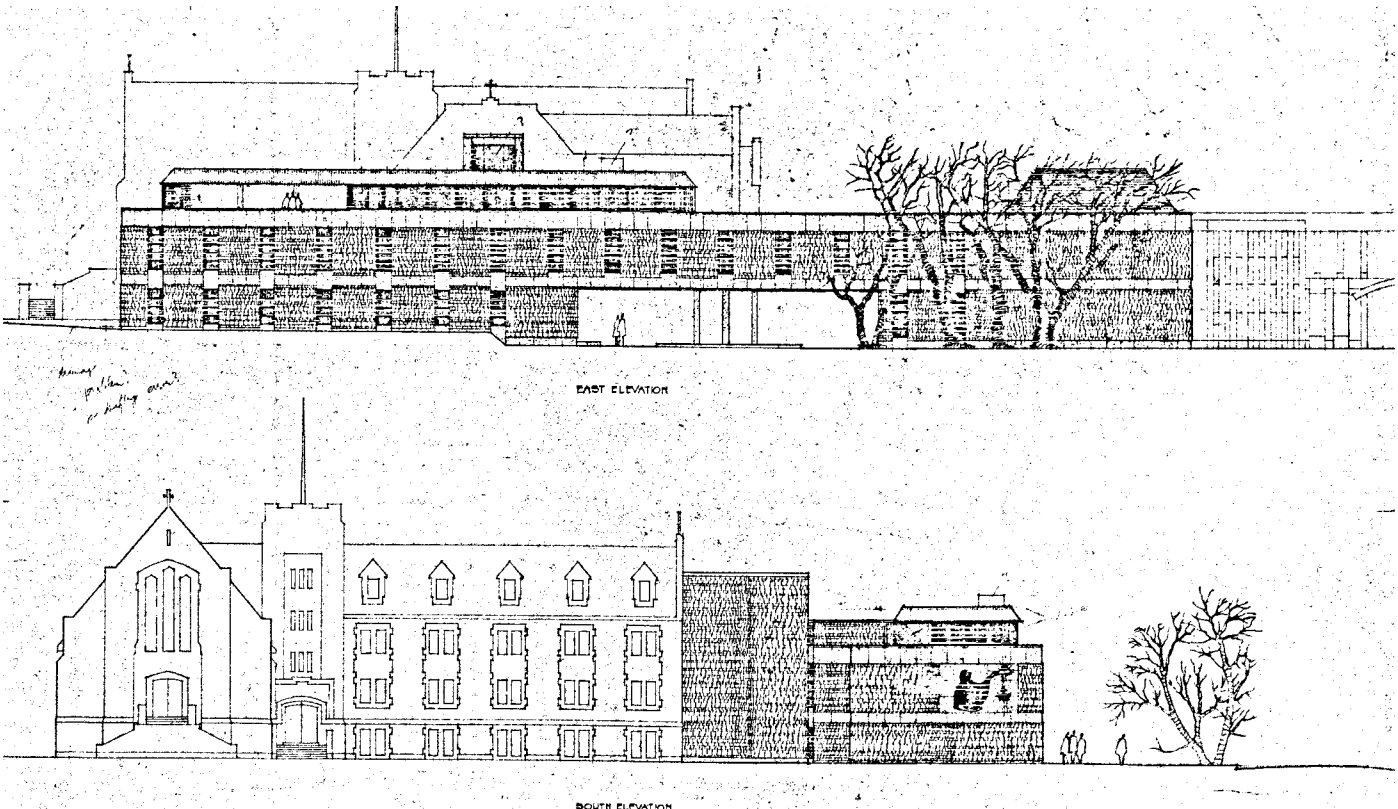

Figure 26. Elevations of STM College after the completion of the 1960's addition. Retrieved from Facilities Management Division Asset Record system, File ST-81-T.

2.3 Location

St. Thomas More College is located prominently along College Drive on the University of Saskatchewan campus. Prior to the construction of its greystone buildings, the first Catholic chaplain facility, Newman Hall, was located on the same site. Also known as the 'white house,' Newman Hall was constructed in 1927 and contained a chapel and club rooms for Catholic students. In 1936 it became known as St. Thomas More College. In 1943 the White House was enlarged to meet the needs of the growing student population. (The White House is visible in Figure 37, a photograph taken during the construction of the new building.)

The location of St. Thomas More on the university campus, and its architectural design as a Collegiate Gothic greystone building, gave physical expression to its status as a federated college of the University of Saskatchewan. In 1954, the current building was constructed immediately adjacent to the White House on the southern boundary of the main campus property. For a short time, the White House and the new stone facility both existed on the site. With the completion of the new building, the White House was offered to the university at no cost, save for the expense of moving it. When the university declined, the building was sold to a local contractor and was removed (Sanche, p. 104). The 2013 addition to the building occupies the former site of the White House, and when excavations for this addition were undertaken, some of the materials of the white house were unearthed.

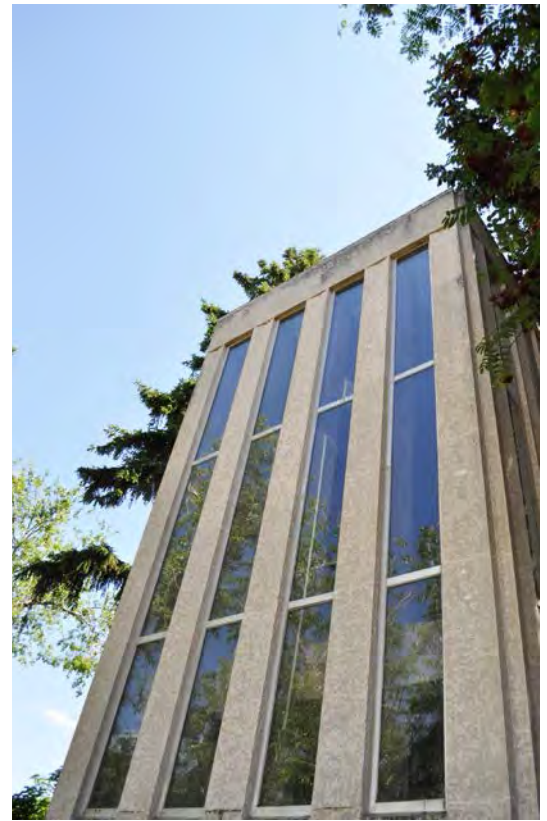

Figure 27. Stair tower.

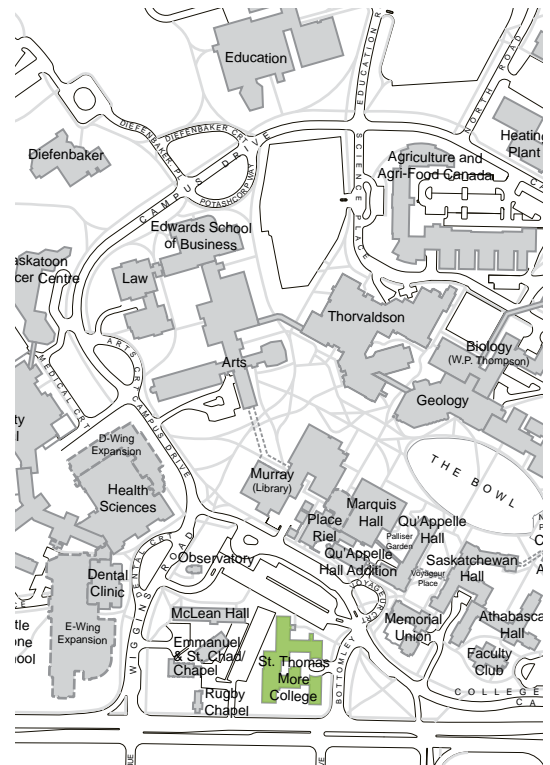
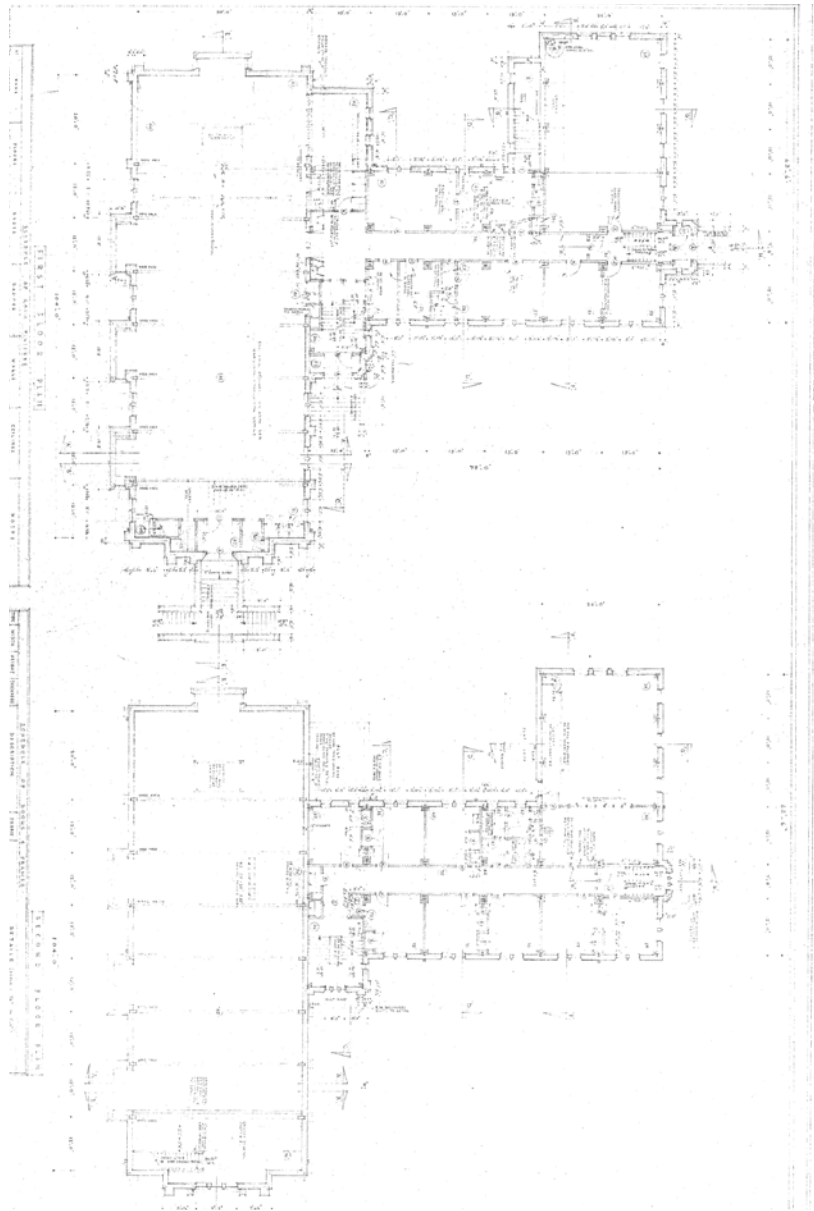

Figure 28. The location of St. Thomas More College is indicated in green on this contemporary campus map.

Figure 29. Top to bottom: first and second floor plans for the 1954 building. Retrieved from Facilities Management Division Asset Record System, File 934-243-T.



Figure 30. The current configuration of the chapel with the pews facing west. The high ceiling is a character-defining element.



2.4 Spatial Configuration



Figure 31. A 1957 photo of the interior of the original library, now the double height Chelsea Lounge. Photo A.12, retrieved from St. Thomas More College Archives.

The spatial configuration of the original 1954 building can be best described by distinguishing the chapel wing from the wing of administrative offices and dormitory rooms. The chapel is oriented north-south, with its narrow dimension facing College Drive to the south. The chapel itself is located on the 1st floor. It is a large open space, with a clear-span structure, and a high peaked ceiling. Over time, the chapel's configuration has been changed. Originally the altar was situated on a raised platform at the north end of the chapel in front of a large painted mural by the artist William Kurelek. The pews were arranged facing north in parallel rows. In response to liturgical reforms stemming from the Second Vatican Council of the 1960's, the orientation of the chapel was changed so that the pews face the western wall of the chapel where the altar is now located. The raised choir loft above the sacristy at the south end of the chapel is a character-defining element. The high vaulted ceiling also defines the character of the chapel. The basement level below the chapel contains an auditorium.

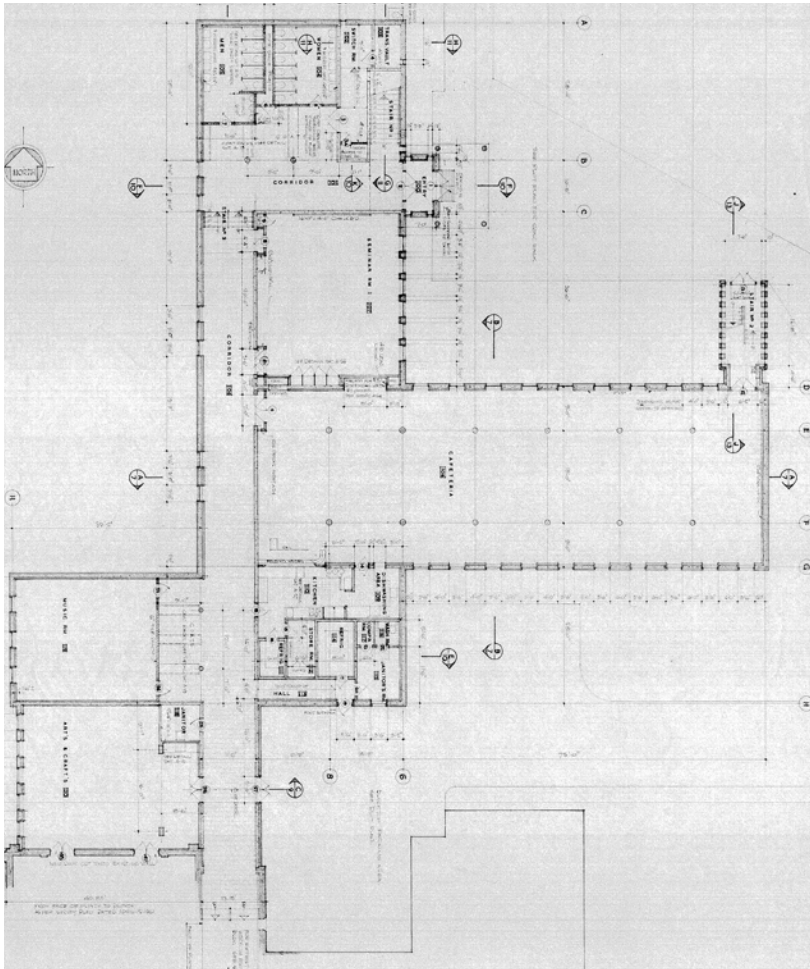

Figure 32. The first floor plan of the 1963 addition. Retrieved from Facilities Management Division Asset Record system, File ST-51-T.

The administrative and residential wing runs east-west, parallel to College Drive, and comprises three floors. It is joined to the chapel at the main entrance and vestibule, which are marked on the exterior by a stair tower. Each floor of the administrative and residential wing is organized around a double-loaded corridor, with rooms arrayed on either side. This configuration has been maintained and is a character-defining element. On the first floor, a library was located on the north side of the wing, at its eastern end. Now a social lounge, the character of this room is defined by its high ceiling and windows. The book shelves and mezzanine that were once in the room have been removed.

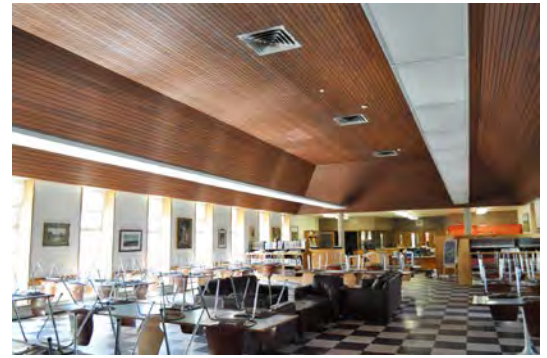

Figure 33. The library: large, open plan configuration with numerous windows and character-defining cedar panelled ceiling.

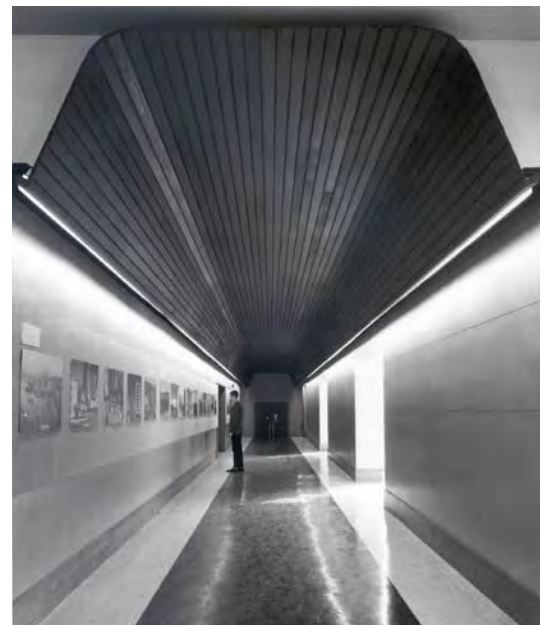
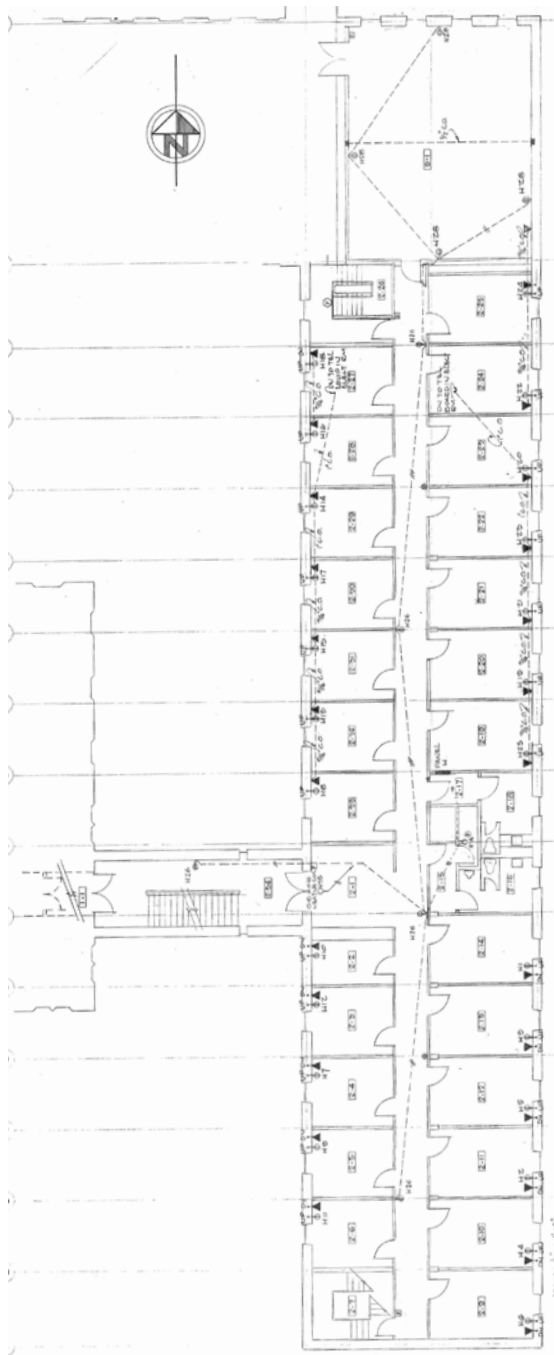

Figure 34. A 1963 photo of the gallery hallway. Light shed from the cantilevered lightwells is visible in the right half of the photograph. Photo A.31, retrieved from St. Thomas More College Archives.



The 1963 addition is located to the north of the original wing, and connects at the north side of the main entrance vestibule, just east of the chapel. On the basement level, it contains a large cafeteria, associated service spaces and a seminar room. On the 1st floor, the 1963 addition houses a library above the cafeteria, a seminar room, offices, and a 'walk-through' art gallery. Funding for the addition came partly from grants provided by the Canada Council for the Arts. In order to be eligible for more funding, the architect was challenged to designate as much of the building as possible to education in the social sciences and humanities. The walk through art gallery was conceived as a way of increasing the floor area in the building devoted to the arts, thereby increasing the value of the grant. By designating what would otherwise be considered a hallway as an art gallery, STM was able to secure more funding.

The 1969 addition, also known as the East Office Wing, is a linear wing running north-south, located parallel to Bottomley Avenue, and connecting the eastern end of the original building back to the 1963 addition. It included offices on the Ground and 1st floors, and a faculty lounge called the Chelsea Room on the third floor, connected to a roof-top patio. The Chelsea Room was named for St. Thomas More's home town in England. In 2003, this lounge was enclosed and converted into classroom space. The Chelsea Room was re-located to the former library space in the original wing. The spatial configuration of the rest of the 1969 addition has been maintained. The double loaded corridors, student lounge space and the lecture room have all been maintained, although the 2013 addition may see some changes to these spaces.

Figure 35. First floor plan of the 1969 office wing addition. Retrieved from Facilities Management Division Asset Record System, File St-88-T.

2.5 Systems

Although the original structural drawings no longer exist, the administrative and residential wing of the 1954 building appears to be a steel framed building. The roof structure is a system of steel beams and purlins, supporting wooden rafters. Steel beams and columns support floors consisting of a concrete topping and slab on open web steel joists. Exterior walls incorporate structural steel columns, and consist of greystone and cast-in-place concrete. Foundation walls and footings are of cast-in-place concrete. The chapel wing has a similar structure, except that the roof and walls of the chapel above the 1st floor level have a structure consisting of glue-laminated wood arches and purlins, supporting wooden rafters.

The 1963 and 1969 wings have a concrete structure, except for their roofs, which have a steel structure. The roof structure on the 1963 wing consists of steel beams supporting an unusual system of insulating structural calcium silicate panels. These panels, manufactured by a company called ‘Y-Tong’ are more common in Europe, but are rarely used in North America. They are of a material similar to concrete, but are air-entrained to reduce weight and increase their insulating value. The rest of the building has a more conventional structure of stone-faced concrete walls and concrete columns supporting cast-in-place concrete beams and slabs. The foundation walls and footings are also of cast-in-place concrete. Some interior concrete columns in the 1960’s portions of the building are finished in an exposed aggregate concrete, and are still visible. A few of these columns exist in the cafeteria, although most were removed in renovations in the early 2000’s. Large beams were dropped beneath the ceiling of the space to pick up the load that had been carried by the concrete columns. Exposed structural systems were a defining characteristic of the Modern architectural style. Where structural elements are exposed to view, such as the concrete columns in the cafeteria or the glu-lam arches in the chapel, they should be considered character-defining elements.

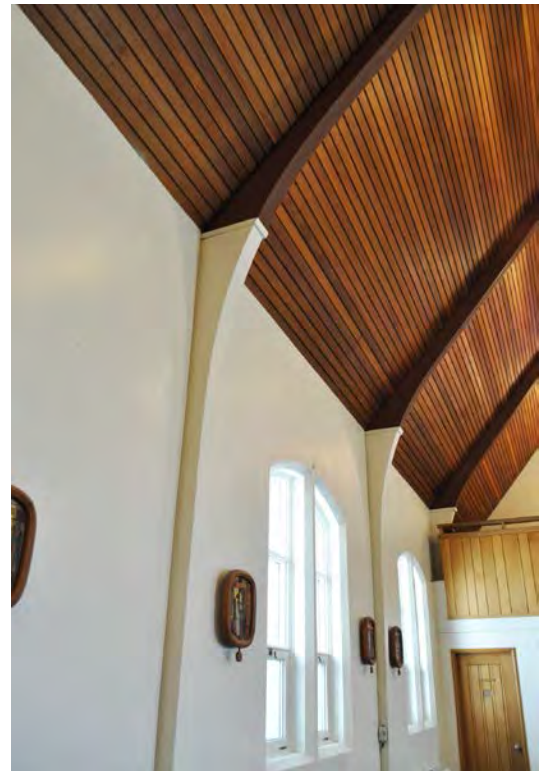

Figure 36. Exposed glue-laminated ribs in the chapel.



Figure 37. STM under construction, 1953-1956. Photo B.05, retrieved from St. Thomas More College Archives.

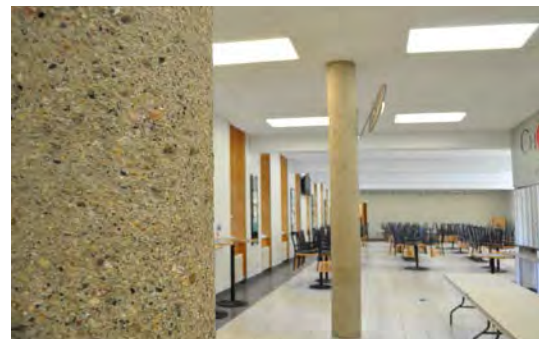

Figure 38. Exposed aggregate finish on concrete columns.



Figure 40. The Newman Glee Club performing in the St. Thomas More auditorium, 1957. Photo A.66, retrieved from St. Thomas More College Archives.

The building features several intricate wooden grilles where ventilation and cooling are delivered. The chapel has a wooden screen in a geometric pattern (Figure 39). This operable screen can be opened or closed to control ventilation. Above the library door is a grille made from walnut. The cafeteria features a large oak grille. Many windows feature wooden radiator covers. The cafeteria has retained its original radiators, which are still in use. One can be found beneath each window. The radiators are character-defining as a visible system indicative of the time of construction.

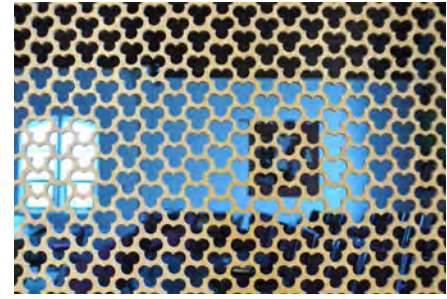

Figure 39. Wooden ventilation grille.



Figure 41. STM's Shannon Library in use, 1963. Photo A.39, retrieved from St. Thomas More College Archives.

2.6 Uses

Although St. Thomas More College has always been a Catholic college at the University of Saskatchewan, the nature of the education provided through STM has evolved. The institution began as a traditional religious college with a mandate to provide Catholic teaching and care to Catholic students. In response to the reforms of the Second Vatican Council of 1962-65, and increased interest from the non-Catholic student body, St. Thomas More became more flexible and open in its policies around the religious affiliations of students and faculty. As the college grew, it became a more integral part of the University of Saskatchewan rather than a separate, but related institution. Today, any student enrolled at the University of Saskatchewan may take classes at STM and the college offers many of the same classes that the College of Arts and Science offers.

The first STM stone building consisted of a chapel, sacristy, Newman club room, library, kitchen, dining area, offices and a residence area for the Basilian Fathers. The second stage of the building brought a cafeteria, a larger library, an art gallery and a lecture room. The third stage of construction became known as the east office wing and provided offices, seminar rooms, an enlargement of the library stacks area, a student lounge and the Chelsea Room. With minor changes over time, the building is generally still used for its original intended purposes.

The only major change in use has been to the two upper floors of the original 1954 building, which were originally residential accommodation for Basilian Fathers, but are now used as offices. "St. Thomas More College never did operate its own residence, and is perhaps the only Catholic college in Canada which has not done so." (Sanche, p. 90).

In 1936, St. Thomas More College made a temporary agreement with the university to use the larger institution's classroom space. The college and the university came to regard this arrangement as mutually beneficial, and as the construction of the more permanent greystone structure was planned, President J.S. Thomson insisted that the arrangement continue. The 1953 building was therefore built with little provision for classroom or lecture space.

2.7 Cultural & Chronological Associations

St. Thomas More College is unique as the only federated college at the University of Saskatchewan. Its relationship to the university was modeled on the relationship between St. Michael's College and the University of Toronto. As such, STM is part of the university, but dependent on its own funding. It uses university facilities and confers degrees from the University of Saskatchewan, but hires and pays its own faculty. STM became an affiliated college of the University of Saskatchewan in 1936, and was formally recognized as a federated college in 1953 after this category was added to the university statutes.

The Shannon Library is named for the construction company that built the first stage of the college (Figure 42). Shannon Brothers, General Contractors was run by brothers Dennis, Joe and Frank Shannon, who had all been members of the Newman Society. Their construction company had built many of the Catholic churches and schools in Saskatoon.

The building can be associated with the saint for whom the college is named. Sir Thomas More was canonized in 1935 as a martyr of the schism that separated the Church of England from the Catholic Church. Sir Thomas More lived from 1478 to 1535, and was an English lawyer, social philosopher, author, statesman, and noted Renaissance humanist. He was an important advisor to Henry VIII of England and Lord Chancellor from 1529 to 1532. More also wrote *Utopia*, published in 1516, about the political system of an ideal and imaginary island nation. More opposed the Protestant Reformation generally, and opposed the separation of the Church of England from the Roman Catholic Church, refusing to accept King Henry VIII as Supreme Head of the Church of England. Tried for treason, More was convicted and beheaded in 1535.

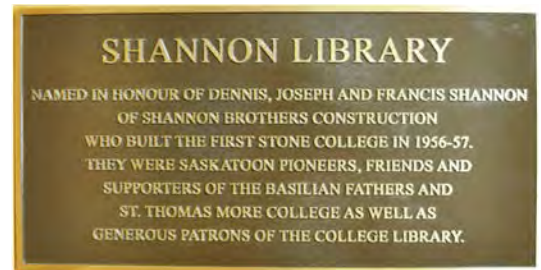

Figure 42. Plaque commemorating the Shannon Library.



Figure 43. Granite altar.



Figure 44. Mural: *Mary Queen of the Universe*.



Figure 45. Stained glass windows, designed by Robert Rambusch.



Figure 46. The Kurelek mural surrounds the inset mural done by Lionel Thomas.

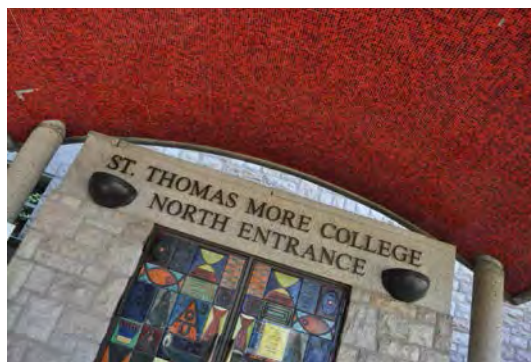

Figure 47. Enamelled cloisonne doors under an arched portico finished in brightly coloured ceramic tile.

3. Associated Objects

The black granite altar located in the chapel was a gift from the Hoeschen family in 1954 (Figure 43). The altar, designed by Vancouver artist Lionel Thomas, features a motif of jugs, loaves and fish. The whole top of the altar was consecrated as the altar stone. Prior to the Second Vatican Council, mass could only be celebrated on a stone altar containing the relics of saints. The bones of three female martyrs: St. Digna, St. Justa and St. Maria Goretti were placed in the sepulchre cavity of the altar and covered with a stone slab.

Several works of art were commissioned or gifted with the first stage of construction of St. Thomas More College. In addition to the altar, a mural by the same artist adorns the bay at the north end of the chapel. The Mural of *Mary, Queen of the Universe*, as it is known, features a stylized portrayal of Mary with angels and other symbolic figures (Figure 44). The mural was the gift of the Catholic Women's League of Saskatchewan. On the large wall surrounding this mural is a work by Alberta born artist William Kurelek (Figure 46). Painted in 1976, the Kurelek mural was a gift from the Basilian Fathers to STM on the 40th anniversary of the college. The mural has a major theme of the union of humankind with God and a minor theme of Christ's multiplication of loaves and fish. The themes are depicted in the setting of a Saskatchewan wheat field. Kurelek passed away the year after completing what he termed his, "first proper mural." The copper doors found in the original portion of the building are also works of art. The doors were designed by Lionel Thomas and feature the crests of St. Thomas More and John Henry Newman. All four sets of copper doors are still in existence.

The 1963 portion of the building saw the addition of the multi-colored ceramic doors of the north entrance as well as a bronze sculpture of St. Thomas More (Figures 47 & 48). Both pieces were made in 1963 by Lionel Thomas. The bronze sculpture originally adorned the library wing, but was moved in 1969 to the southeast corner of the building facing College Drive.

The cornerstone of the building is located on the stone wall of the exterior chapel stair. The stone is weathered and much of the text is no longer discernible (Figure 50).

4. Supporting Documents

Facilities Management Division (2011). Asset Resource Database [Data File]. Retrieved from \\usask\fmddfs\files\iis\IIS_Public\ARS

Sanche, M. (1986). *Heartwood: A History of St. Thomas More College and Newman Centre at the University of Saskatchewan*. Muenster, SK: St. Peter's Press.

University of Saskatchewan Archives. (Retrieved 2011). *Campus Buildings: St. Thomas More College*. Retrieved from http://scaa.sk.ca/gallery/uofs_buildings/



Figure 48. Bronze sculpture, *The Moment of Truth*, by Lionel Thomas.



Figure 49. A stone crest reads, '1955' at the top of the tower.



Figure 50. The cornerstone, showing signs of weathering.

5. Summary of Character - Defining Elements

Materials

- greystone walls
- granite base
- Tyndall stone trim and detailing
- cedar paneling
- black slate floor
- copper doors
- black granite chapel fixtures
- maple doors
- aluminum and steel framed glazing
- steel staircase, and balustrade
- oak banisters
- glazed tile wainscoting
- stained glass windows

Form & Style

- corbels
- stone piers
- peaked roof and parapets
- archer slots
- statuary niche references
- gothic arched doors and stone
- lancet windows
- dormer windows
- quoins
- exposed glue-laminated arches in chapel
- cantilevered bays on chapel
- stone blanks
- stained glass

Location

- College Drive
- University of Saskatchewan

Spatial Configuration

- double height chapel with vaulted ceiling
- double-height Chelsea Lounge
- double-height library
- auditorium
- stair towers

Systems

- exposed glue-laminated arches in chapel



Uses

- worship
- dining
- study
- library
- lectures
- auditorium
- art gallery
- residence (Basilian fathers)
- offices

Cultural &
Chronological
Associations

- Catholic Church
- federated college
- St. Thomas More
- Kurelek mural
- stained glass windows
- copper doors
- ceramic doors
- 1955 crest



935

College of Emmanuel & St. Chad



935

College of Emmanuel & St. Chad

Alternate Names
Emmanuel College

Architect(s)
David R. Brown and Hugh Vallance, Brown and Vallance Architects, Montreal

Builders
Smith Brothers and Wilson, General Contractors

Construction Dates
1910 -1911

Recognition
University of Saskatchewan 'A' Listed

1. Statement of Significance

The College of Emmanuel and St. Chad is an historic institution whose inception predates the province and the University of Saskatchewan. The institution was the first establishment for higher education founded in Canada west of Winnipeg. In 1883, an act of parliament incorporated the institution as the 'University of Saskatchewan.' Therefore, Emmanuel College nominally existed as the first university in the province until 1907 when the provincial university at Saskatoon was established. At that time, the College agreed to relinquish its name to the provincial university in favor of becoming 'Emmanuel College' and affiliating with the newly born University of Saskatchewan. Despite relinquishing its name, Emmanuel College retained its university charter and rights, and in 1914 became the University of Emmanuel College.



Figure 1. L to R: Sandstone accents, greystone wall.



Figure 2. Carved wooden rafter ends.



Figure 3. The College of Emmanuel & St. Chad, ca. 1960. Photo A-3669, retrieved from University of Saskatchewan Archives.

In 1964 Emmanuel College merged with St. Chad's College of Regina to become the College of Emmanuel and St. Chad. The stone building that now stands as the College of Emmanuel and St. Chad was one of the first stone buildings built on the University of Saskatchewan campus and its existence represents the historical theological institution.

Note: The College of Emmanuel and St. Chad building is configured with floors numbered Basement, Ground Floor, First Floor, Second Floor, Third Floor. This report follows the same convention.

2. Character - Defining Elements

2.1 Materials

The materials used to construct the College of Emmanuel and St. Chad are characteristic of and harmonize with the rest of the University of Saskatchewan campus. 'Greystone' makes up the exterior of the building. Sandstone was used for accents and the exterior steps and base were constructed of granite. Figure 1 shows sandstone string courses on a field of greystone. (For further information on building stones used at the U of S, refer to [Appendix: Stone](#).) The roof of the College of Emmanuel and St. Chad is clad in slate tile and is supported by wooden rafters. The rafter ends were extended as decorative elements on the exterior of the building, as shown in Figure 2. Also visible in Figure 2 are the copper eaves troughs. Copper downspouts carry rainwater to the ground.

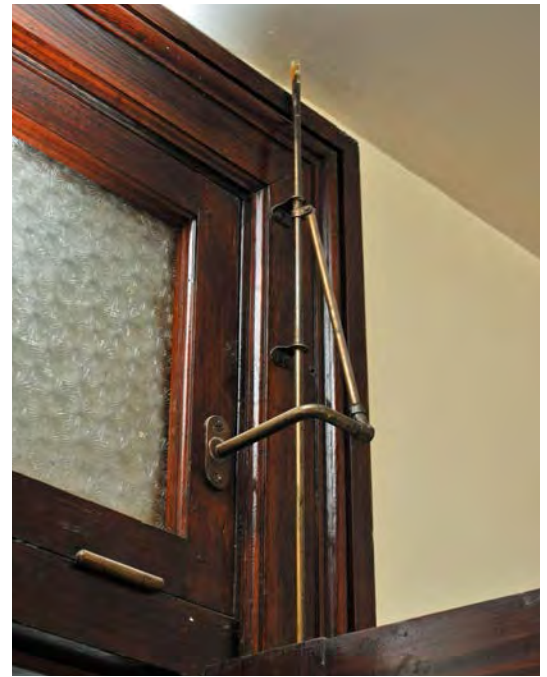

Figure 4. An oak door fitted with a transom window featuring the original brass hardware.



Figure 5. This coiling partition made of Douglas Fir was covered by gypsum board in 1992.



Figure 6. Top to bottom: Plaster wall, oak baseboards, original hardwood flooring.



Figure 7. Wooden staircase.



Figure 8. A 1922 photo shows the one wing that was constructed. Another wing was planned. Call no. B124A.II.SB6716, retrieved from Saskatchewan Archives Board.

The exterior of the building exists in a good state of commemorative integrity, with much of the original material intact. These materials are significant in that they associate the building with the rest of the University of Saskatchewan and contribute to the Collegiate Gothic architectural style of the building. The surviving limestone, sandstone and slate tile are character-defining elements. The same can be said of the materials on the building's interior. Gothic arches and vaults in oak, fir and plaster contribute to the architectural style of the building. Also, the building's interior materials are commonly found throughout other University of Saskatchewan interiors.

Wooden materials characterize the interior of this building to a great degree. Doors, windows and surrounds are made of oak and fir, with matching baseboards and trim. Complementing the wood is bronze and brass hardware such as doorknobs, locks, and latches. Figure 4 shows a wooden transom with brass hardware. These accents complement walls of plaster. The plaster contains horse hair as a binding agent. The staircases are wooden.

The doors and walls exist in varying states of commemorative integrity; in many cases the hardware on doors and windows has been kept in its original form. In some instances the original materials have been refinished or covered; dropped ceilings conceal upper window lites, drywall covers an original fir room partition as shown in Figure 5. The original hardwood flooring visible in Figure 6 is still existent in many places beneath carpet. Original wood flooring has also been covered with vinyl composite tile (VCT) and newer wood flooring in many instances. In these cases the commemorative integrity of the material has been maintained; however the contribution of these materials to the form and style of the building has been compromised by their obstruction.

In other cases the commemorative integrity of the material has suffered. For example, the northern staircase shown in Figure 7 retains its oak finish while the southern staircase has been painted. The same can be said of some of the bronze and brass fixtures.

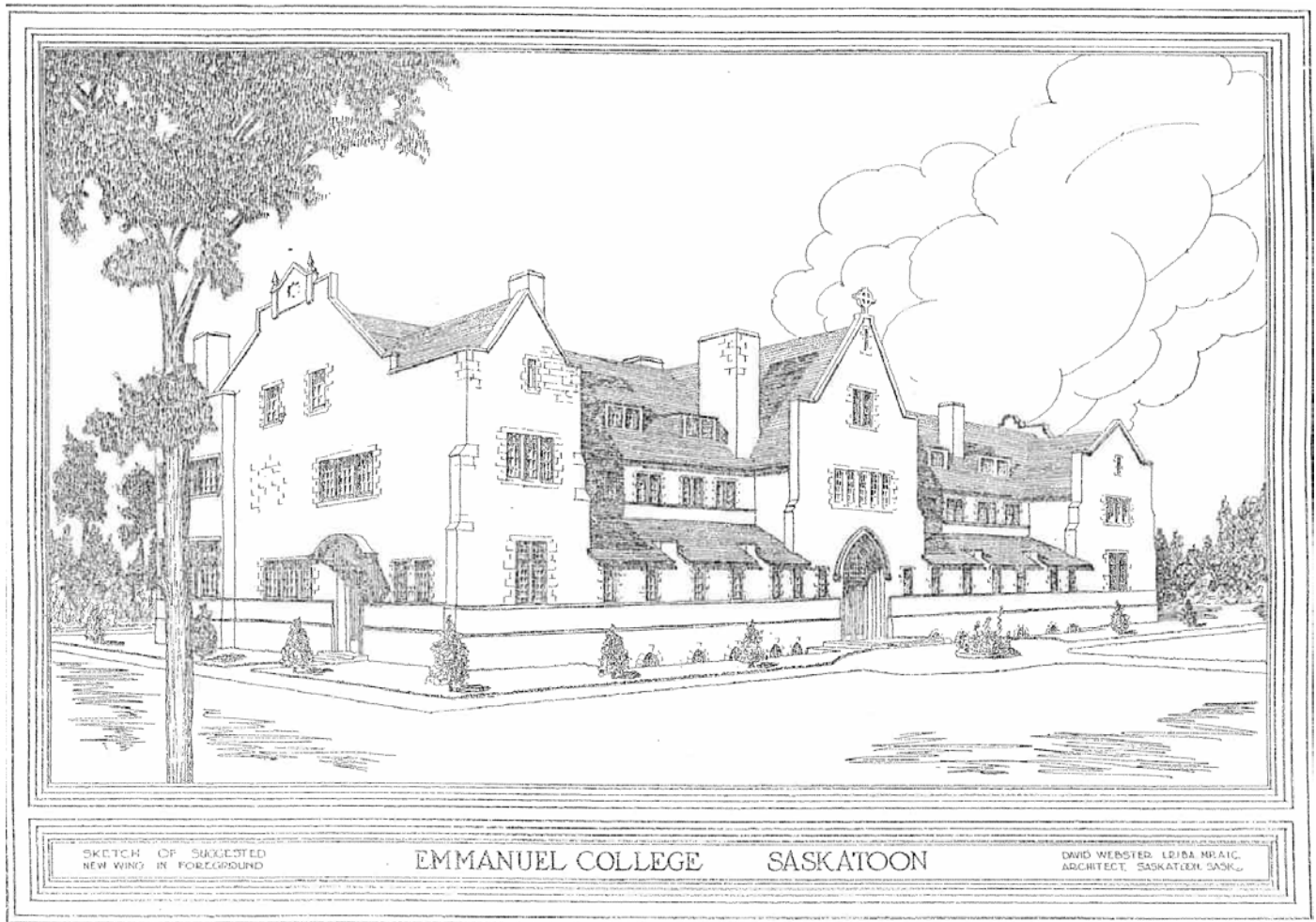

Figure 9. The College of Emmanuel and St. Chad building as originally intended. Call no. B124A, retrieved from Saskatchewan Archives Board.

2.2 Form

The form of the College of Emmanuel and St. Chad, shown in Figures 8 and 9, is in keeping with the context of the University of Saskatchewan. The building consists of one three-storey volume. The floor plan is relatively narrow. The original design, shown in Figure 9, intended for the building to be larger than it was eventually built. A central house for the president was intended to be flanked by two wings. The original building was planned to accommodate 60 students. The First World War and the Great Depression intervened such that construction was never completed. Thus, the College of Emmanuel and St. Chad building, as an incomplete work of architecture, reflects its historical context and the events of its time.

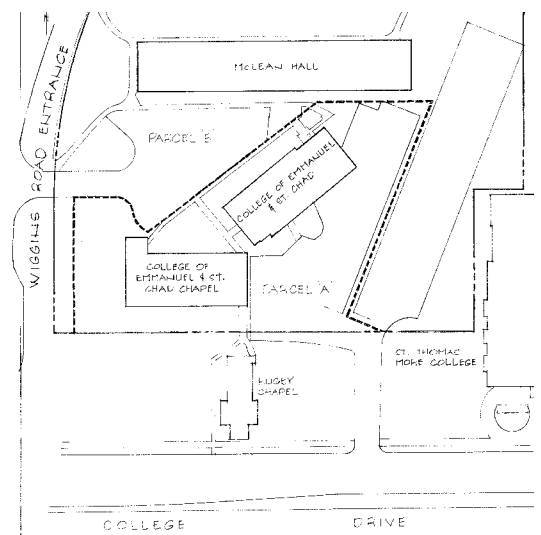

Figure 10. The College of Emmanuel and St. Chad situated between McLean Hall and the Emmanuel and St. Chad Chapel. Retrieved from Facilities Management Division Asset Record System, File EC-88b-T



Figure 11. A photograph of the College of Emmanuel in 1925 shows elements of the Collegiate Gothic style: dormer windows, pointed arches, bay windows, and archer slots. To the left, two ground floor windows already feature a stucco treatment covering their arched transoms. Call no. B124.A.II.SB6715, retrieved from Saskatchewan Archives Board.



Figure 12. A bay window located on the south east corner of the College of Emmanuel and St. Chad. Sandstone quoins surround the window.

2.3 Style

Numerous character-defining elements contribute to the Collegiate Gothic style of the College of Emmanuel and St. Chad. This style is significant as it reflects the relationship of the College to the university; the College of Emmanuel chose to physically represent itself as part of the university.

This style is manifested in the use of dormer and bay windows, gothic arched windows and doorways. Statuary niches and narrow false windows are used as decoration. Openings are surrounded by cut sandstone surrounds. Sandstone quoins adorn corners. Figure 11 shows some of the Collegiate Gothic elements that decorate the facade of this building. Figure 12 shows a bay window decorated with sandstone quoins. The principle entry is located prominently in an archway, pictured in Figure 13. Some slabs of stone were left blank, presumably intended as locations for future ornamentation.

Figure 11 shows an interesting asymmetry on the building's southern facade. Two of the six ground floor windows have had their arched transoms replaced by stucco panels. Today all six windows feature this treatment.



Figure 13. The principal entrance of the College of Emmanuel and St. Chad featuring a gothic arch and transom with stone blanks.

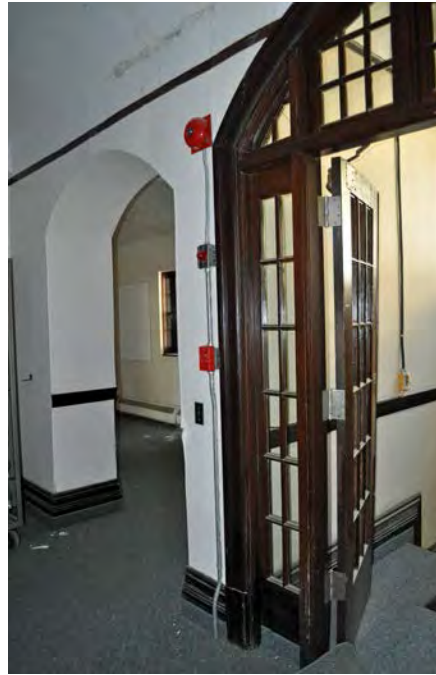

Figure 14. Arched entryways, hallways and doorways with arched transoms characterize the interior of the building as Collegiate Gothic.

The absence of carvings on such a typically gothic building is character-defining. Often builders left room for ornamentation on the exterior of gothic buildings with the intention that the carvings would be carried out following the building's completion. The existence of several of these stone blanks is an important element defining the character and context of this building. (See section 2.8).

The interior of this building is in an intermediate state of commemorative integrity. Figure 14 shows an example of an interior element that harmonizes with the gothic exterior. A ground floor corridor featuring a vaulted plaster ceiling, arched entries and transoms contributes to this effect. However, in many places these character-defining elements have been altered such that they no longer contribute to the heritage value of the building. (Refer to Figure 15.)



Figure 15. A gothic arch window. The arched transom has been hidden from view on the interior by a dropped ceiling. Stucco on obscures the window on the exterior.

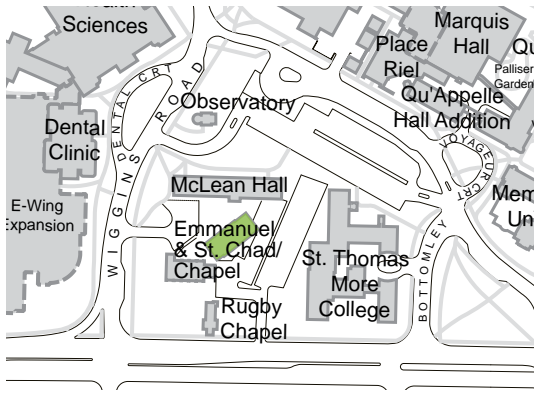

Figure 16. The location of the College of Emmanuel and St. Chad is highlighted in green on this contemporary campus map.



Figure 17. Principal Lloyd leading a procession to take possession of the site of Emmanuel College at the University of Saskatchewan, June 24, 1910. Call no. B124.A.II.SB6227, retrieved from Saskatchewan Archives Board.

2.4 Location

The College of Emmanuel and St. Chad building is located on the University of Saskatchewan campus near College Drive (see Figure 16); however, as an institution, the College was not always located here. The College was founded in 1879 by the Right Reverend John McLean, first Bishop of Saskatchewan, and was originally housed in another building 3 miles west of Prince Albert, where the federal penitentiary now stands. In 1907 the Legislature of the Province of Saskatchewan passed an act to establish a provincial university which was located in Saskatoon, and it was decided to affiliate Emmanuel College with the provincial university. The University of Saskatchewan granted the theological college 5 acres of land at nominal rent which the College of Emmanuel occupied in September of 1909.

The current location of this building is a character-defining element as it signifies Emmanuel College's decision to affiliate itself with the University of Saskatchewan. The move from Prince Albert to Saskatoon indicated the desire of Emmanuel College to be affiliated with the University of Saskatchewan.

In 1910 the Principal of Emmanuel College, the Right Reverend George Exton Lloyd, conducted a ceremony in the English tradition of beating the grounds, in order to claim the location for the theological school. This ceremony is pictured in Figure 17.

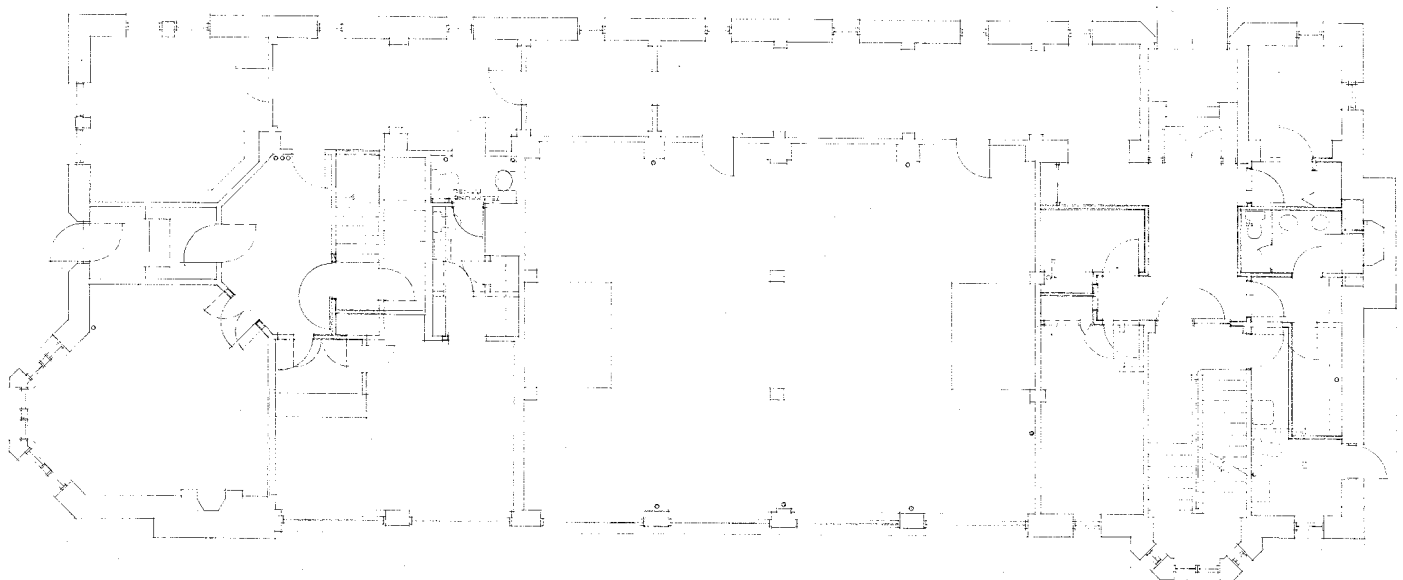

Figure 18. The ground floor plan of the College of Emmanuel and St. Chad. Retrieved from Facilities Management Division Asset Resource System, File EC-94-T

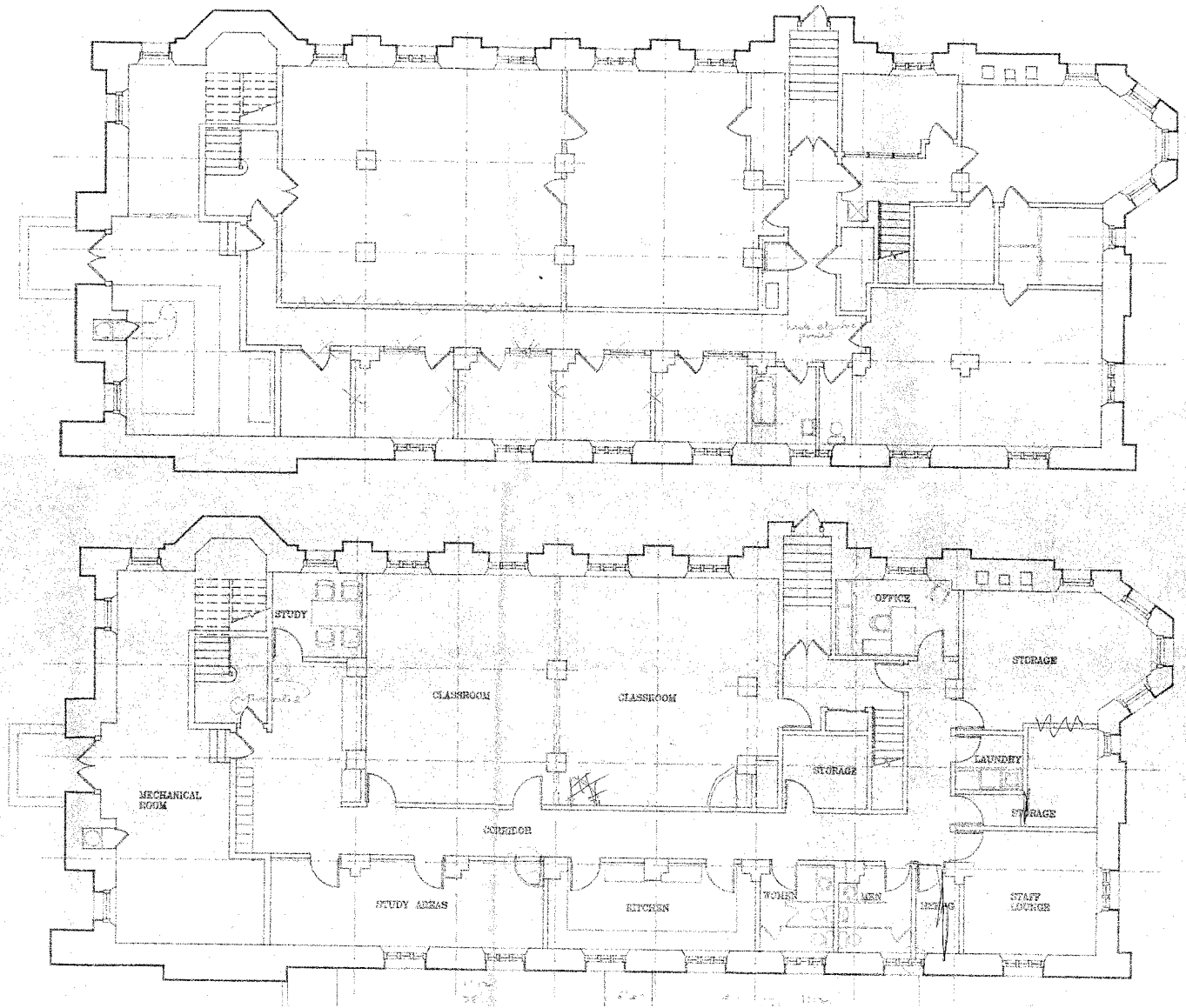

Figure 19. Top to bottom: original basement layout, basement layout after renovations. Retrieved from Facilities Management Division Asset Record System, File EC-91-P.

2.5 Spatial Configuration

The College of Emmanuel and St. Chad has three above ground storeys, and a basement. Aside from the basement, all floors consist of rooms organized linearly and connected by a corridor. As Figure 18 shows, the ground floor contains, in general, larger rooms and more common spaces. The ground floor is accessed by a single-loaded corridor with a vaulted plaster ceiling running along the north-west side of the building. The basement, shown in Figure 19, also originally featured larger rooms and common spaces. Today the basement exists as one large open space. Only the mechanical room and interior storage room from the original layout remain. Figure 20 shows the coal chute still existing in the mechanical room. This is a character-defining element as it associates the building with the time it was built, when coal was a common source of heat.



Figure 20. Coal chute.



Figure 21. Second Floor Plan. Double loaded corridor serving linear rows of small rooms. Retrieved from Facilities Management Division Asset Record System, File EC-95-T .

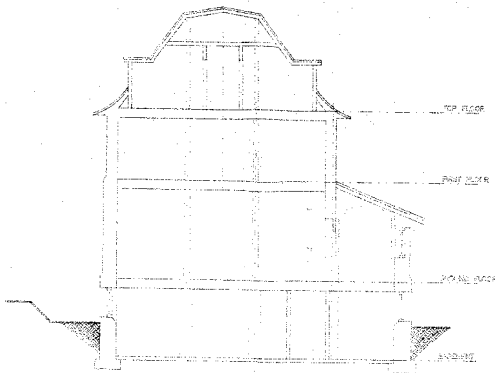

Figure 22. Building cross-section. Retrieved from Facilities Management Division Asset Record System, File EC-91-P.

The upper storeys all consist of double-loaded corridors lined with dormitory rooms. Figure 21 shows a floor plan of the second floor. As Figure 22 indicates, the rooms on the upper floor are characterized by sloped ceilings, due to their location directly underneath the gabled roof.



Figure 23. Concrete columns in the basement have been underpinned to address structural degradation.

The narrow floor plan of this building and its numerous windows are character-defining elements as they illustrate the intention of maximizing natural light. Although this building was constructed to use electric lighting, its configuration takes good advantage of natural light. Figure 15 shows the manner in which the natural lighting of some interior spaces has been compromised.

Another alteration made to spaces in this building has been the furring out of interior walls. With advances in insulating techniques, many of the walls have been built out in order to add fibreglass insulation. In doing so, these spaces have been made slightly smaller due to the thickening of their walls. The recovering of many walls has also obscured some character-defining elements. A fireplace was found obscured by gypsum board on the ground floor. This represents another instance in which renovations have compromised an historical character-defining element of the building.

2.6 Systems

The structure of the College of Emmanuel and St. Chad is hierarchical. This is apparent on the building facade as the exterior walls thicken discernibly towards the base of the building. The building's foundation is made of concrete and concrete columns are visible in the basement; as Figure 23 shows, these columns have been underpinned to repair concrete degradation. The exterior walls of the building are load bearing and are made of stone. The interior structure consists of a wooden post and beam system which supports the floor joists. An exception to this interior system is a load-bearing brick wall in the ground floor corridor. Figure 24 shows a vaulted ceiling formed of plaster on wooden lath.



Figure 24. Arched ceiling in the first floor corridor.

2.7 Use(s)

Emmanuel College was first founded in order to train a native pastorate. The function quickly evolved into a theological college providing education in divinity. To serve this function the College of Emmanuel building was built to provide classrooms, residence rooms for students and for the college Principal, and a refectory in the basement. Referring again to Figure 21 and 22, one can see the dormitory rooms arrayed along double-loaded corridors in the upper floors of the building.



Figure 25. Dr. Griffith Thomas with his Deacon's class at Emmanuel College in 1911. Call no. B124.A.II.SB6638, retrieved from Saskatchewan Archives Board.

Figure 25, a photograph of a Deacon's class in progress, illustrates the main purpose of the building. As Figure 18 shows, the floor plan of the first floor of the building was planned to accommodate educational uses with larger lecture spaces. The basement originally housed a refectory or dining hall as pictured in Figure 26. In later years, uses were rearranged and classrooms were built in the basement. Figure 19 shows this rearrangement. As Figure 27 illustrates, a library was also housed within the building during its early years.



Figure 27. Lecture room and old library in Emmanuel College ca. 1930. Call no. B124A.II.SB6719, retrieved from Saskatchewan Archives Board.



Figure 26. Dining Room in Emmanuel college ca. 1930. Call no. B124.A.IISB6720, retrieved from Saskatchewan Archives Board.



Figure 28. Bishop Lloyd turning the sod for the construction of Emmanuel College, June 24, 1910. Call no. B124A. II.SB3989, retrieved from Saskatchewan Archives Board.



Figure 29. The cornerstone of the College of Emmanuel and St. Chad building.

During 1916, the building was used as a military hospital for soldiers in World War I. Two years later the building was again used as a hospital, this time for those afflicted with influenza during the epidemic of 1918. The building's roles in these events situate it within the larger context of world history.

After being closed for educational functions for a brief period during the First World War, the building resumed its original purpose of providing divinity training. The College of Emmanuel and St. Chad building functioned as a residence until 2005, when the College moved its operations to the [Lutheran Seminary](#). Although the uses within the building were often rearranged, it should be noted that the overall use of the building remained the same, functioning as an educational institution and a residence, up until its closure.

2.8 Cultural & Chronological Associations

As discussed in Section 2.7 'Uses', the College of Emmanuel and St. Chad can be associated with the time periods in which it served. Its use as a hospital during both wartime and the influenza epidemic is an aspect of its history worthy of recognition.

Decorative stone carvings intended to adorn the flat stones visible in Figure 13 were permanently delayed due to the more pressing need to devote resources to World War I. These stone elements, so uncharacteristic of the gothic style, have become character-defining for the way they associate the building with the events of its time.

The building can also be associated with the Right Reverend George Exton Lloyd. Lloyd was instrumental in the realization of the building as it stands on the University of Saskatchewan campus. Lloyd moved the College to Saskatoon and brought sixty students over from England to study at the College. Figure 28 shows Principal Lloyd at the sod-turning ceremony marking the start of the construction of Emmanuel College. A notable association is that the city of Lloydminster is named for the Rt. Reverend Lloyd. Lloyd served as Principal of the College until he resigned in 1916. Lloyd went on to become Bishop of Saskatchewan.

The College of Emmanuel and St. Chad is also associated with Bishop Jervois Newnham, Saskatchewan's Bishop at the time of the building's construction. Newnham laid the cornerstone of the building in 1911. The stone (Figure 29) still exists today in commemoration of the event (Figure 30).

Before the construction of its permanent building, the College of Emmanuel famously functioned as a 'College of Shacks.' In 1909, when the college first moved to the U of S campus, there was a faculty and a body of students, but no formal facilities. Until the current building was realized, the students and teachers had to study in a series of makeshift shacks pictured in Figure 31.

The College of Emmanuel and St. Chad is also associated with the late alumnus Herbert Girling. Girling is a historically significant figure as he was the first person to translate parts of the Bible into Inuktitut. Girling wrote the Gospel of St. Mark in the dialect of the Inuit of Coronation Gulf as well as translating catechisms, hymns and scripture into the Inuit language. Girling spent five years volunteering in the arctic region of Coronation Gulf before he died at 29 of influenza.

3. Associated Objects

N/A

4. Supporting Documents

Author Unknown. (October 29, 1929) Emmanuel College Celebrates Jubilee. *The Saskatoon Star Phoenix*, pp. 6.

Author Unknown. (June 13, 1929). The College of Shacks. *Canadian Churchman*, pp 376.

Author Unknown. (June 13, 1929). The Future of Emmanuel College: A Challenge and an Appeal. *Canadian Churchman*, pp 383.

Author Unknown. (June 13, 1929). The Theological College and the Student. *Canadian Churchman*, pp 377-381.

Author Unknown. (n.d.). *Who Owns Emmanuel College?* (Unpublished dissertation). College of Emmanuel and St. Chad, Saskatoon.

Greene, D.L. (June 13, 1929). Loves Coronation. *Canadian Churchman*, pp 378, 379

Johnson, A.E. (1929, June 13). Unmeasured Debt of the Church in Western Canada to the Colonial and Continental Church Society. *Canadian Churchman*, pp. 375.

Murray, W.C.. (June 13, 1929). Emmanuel and the University of Saskatchewan. *Canadian Churchman*, pp 384.

Reverend Crabb. *History of Emmanuel College*. CFQC TV.

University of Saskatchewan Archives. (Retrieved 2011). *Campus Buildings: Emmanuel College/Rugby Chapel*. Retrieved from http://scaa.sk.ca/gallery/uofs_buildings/



Figure 30. Laying the cornerstone, 1911. Courtesy of Saskatchewan Archives Board, call no. B124.A.II.SB6656



Figure 31. 'College of Shacks' Courtesy of Saskatchewan Archives Board call no. B124.A.II.SB6635.

5. Summary of Character - Defining Elements

Materials

- 'greystone' walls
- sandstone details & trim
- wooden rafter ends
- copper drainage hardware
- slate tile roofing
- oak doors, surrounds, staircases and base boards
- plaster
- bronze and brass fixtures
- wooden flooring

Form

- single massing
- pedestrian scale (three storeys)
- incomplete plan

Style

- dormer windows
- bay windows
- gothic arched entries and windows
- statuary niches
- archer slits
- quoins
- stone blanks intended for future carvings
- vaulted ceilings
- arched entries
- decoratively carved staircase

Location

- main campus location affiliates College with University of Saskatchewan
- location of 'College of Shacks'

Spatial Configuration

- linear arrangement around corridors
- double loaded dormitory floors
- narrow floor plate
- fireplaces
- vaulted hallway
- coal chute



Use(s)

- theological college (classrooms, residence rooms, refectory, library)
- military hospital (WWI)
- influenza epidemic hospital

Cultural &
Chronological
Associations

- incomplete cut stone decoration
- incomplete building plan
- Rt. Rev. George Exton Lloyd
- cornerstone laid by Bishop Jervois Newnham
- Herbert Girling

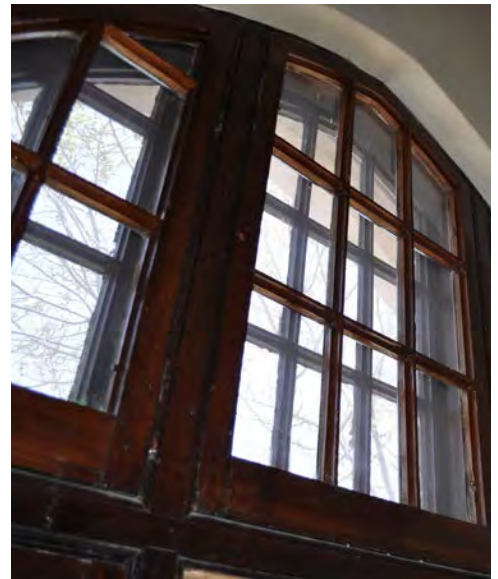

936

Emmanuel & St. Chad Chapel

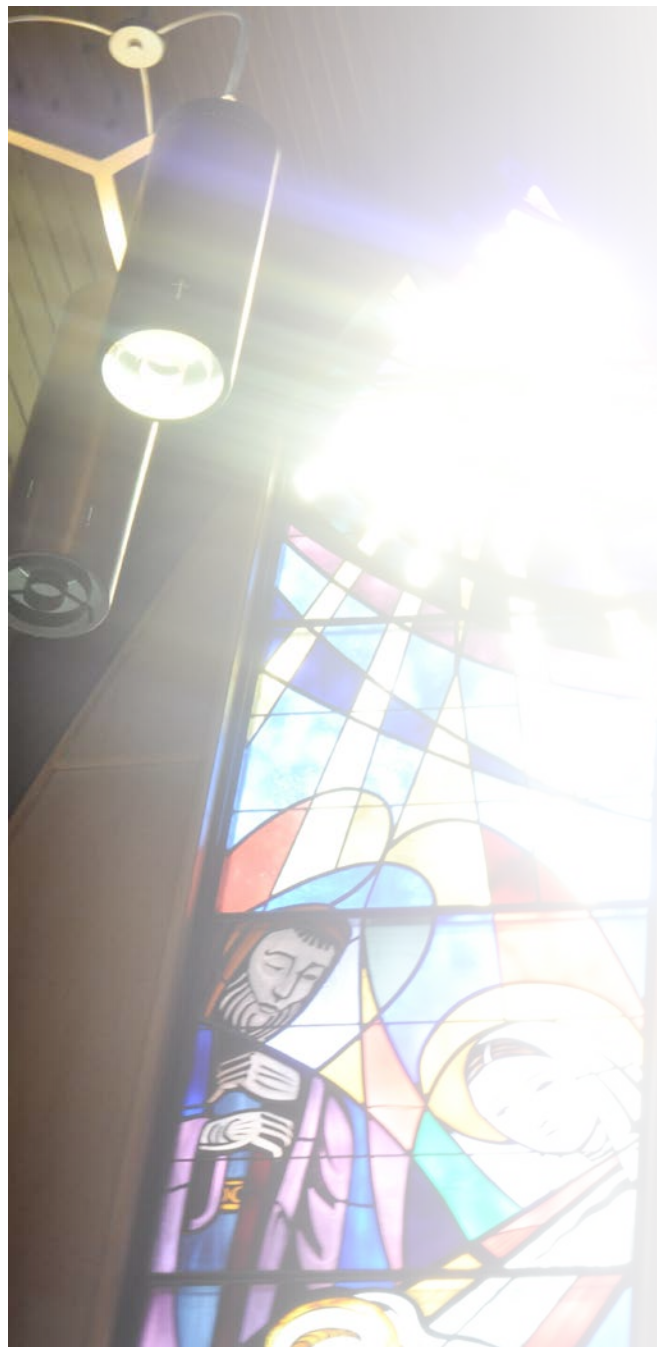

936

Emmanuel & St. Chad Chapel

Alternate Names

Main Chapel

Emmanuel Chapel

St. Chad Chapel

Graduate Student's Association (GSA) Commons

Architect(s)

Webster, Forrester, Scott and Associates, Saskatoon

Builders

Shoquist Construction Ltd.

Construction Dates

1965-1966

Recognition

University of Saskatchewan 'B' Listed



Figure 1. Copper roofing.



Figure 2. L to R: Greystone and Tyndall stone.

1. Statement of Significance

The Chapel of St. Chad, as it was originally known, was designed by Webster, Forrester and Scott of Saskatoon and constructed between 1965 and 1966. The Emmanuel and St. Chad Chapel is no longer used as a church; however, its form and style still commemorate this previous role with a high degree of integrity. The building carries heritage value due to its historic use and its affiliation with the College of Emmanuel and St. Chad. It has architectural value due to its highly successful marriage of the Modern and Gothic styles, representing a contemporary interpretation of both the traditional architectural style of the University of Saskatchewan campus and of the historical forms and conventions of ecclesiastical architecture.



Figure 3. Emmanuel & St. Chad Chapel shortly after construction. The copper roof had not yet taken on its patina. Photo retrieved from Saskatchewan Archives Board, Call no. B124 All.124-125.

2. Character - Defining Elements

2.1 Materials

The defining material feature on the exterior of the College of Emmanuel and St. Chad Chapel is the standing seam copper roof of the nave. This roof takes the form of two intersecting pointed vaults, which reach 40 feet in height, such that the copper roof is the building's most dominant architectural element. In Saskatoon, copper does not turn green as is typical in many other locations, but rather loses its sheen in the clean, dry prairie air and deepens to a dark brown patina. The copper roofing is shown in Figure 1.

The primary material of the exterior walls is rough-faced 'greystone.' This stone is significant as it was chosen as the signature material for university buildings at the outset of campus construction. Cut Tyndall stone is used for window surrounds and accents. The ground floor and basement windows are grouped into a series of vertical slots framed by Tyndall stone. Tyndall stone detailing is also used around copper drainage spouts. The use of greystone on the Emmanuel and St. Chad Chapel signifies its affiliation with both the university and the other theological colleges. Tyndall stone is also considered a character-defining element of later university buildings as it was the accepted replacement for sandstone and Indiana limestone. Greystone and Tyndall stone are shown in Figure 2. (For further information on building stones used at the U of S, refer to ['Appendix: Stone.'](#))

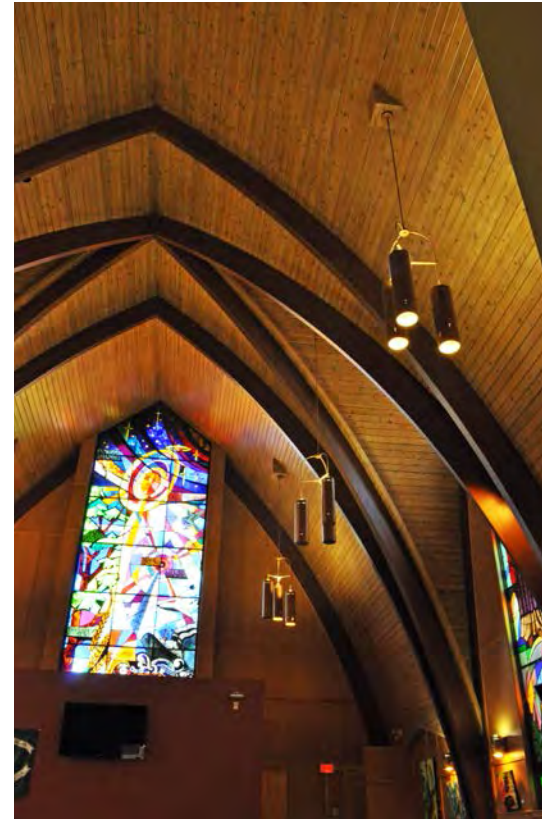

Figure 4. The chapel interior is defined by its fir ceiling and glue laminated arches.

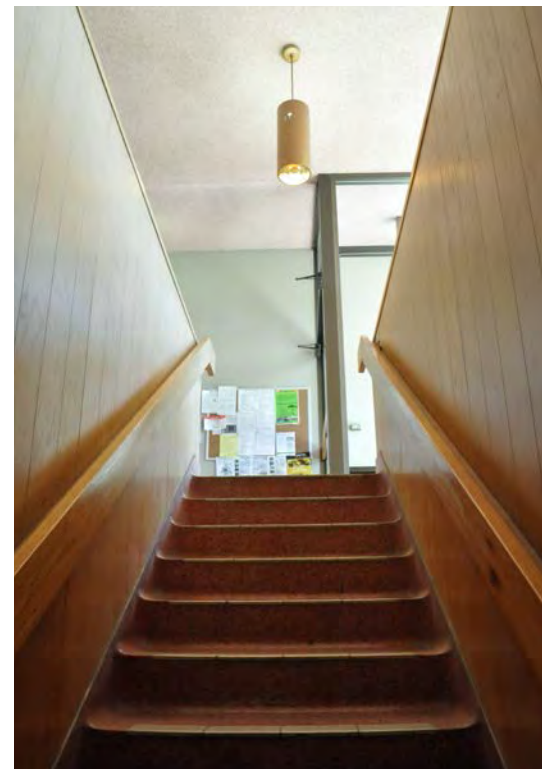

Figure 5. Terrazo stairs, wooden banister and balustrade.



Figure 6. The forms used to compose the College of Emmanuel and St. Chad Chapel.

The stained glass used in this building is another character-defining element. At the head of the chapel nave stands a window 30 feet in height and 10 feet in width. The window depicts the creative works of God and man. Two windows flank this principle window in the transept; one devoted to the College of Emmanuel and one to St. Chad. These windows measure 33 feet high by 4 feet wide. Some windows depict intricate figurative scenes while others are abstract. The windows lend a range of color to the chapel, defining in particular the character of the nave. Because stained glass is a material associated particularly with Christian churches, the windows also reflect the chapel's history as a theological institution. The stained glass has been well maintained and fully retains its commemorative integrity.



Figure 7. The zigzag roof bisects the arched form of the nave contrasting heavy stone with light glazing.

Exposed fir glue-laminated arches extend from the floor to the roof of the nave. Between these ribs, fir roof decking is exposed, as shown in Figure 4.

The entrance foyer is fully glazed, with floor to ceiling aluminum framed curtain wall. The foyer floor features terrazzo that also faces the stairs between the ground and basement floors. Oak paneling accompanies the terrazzo stairs as shown in Figure 5.

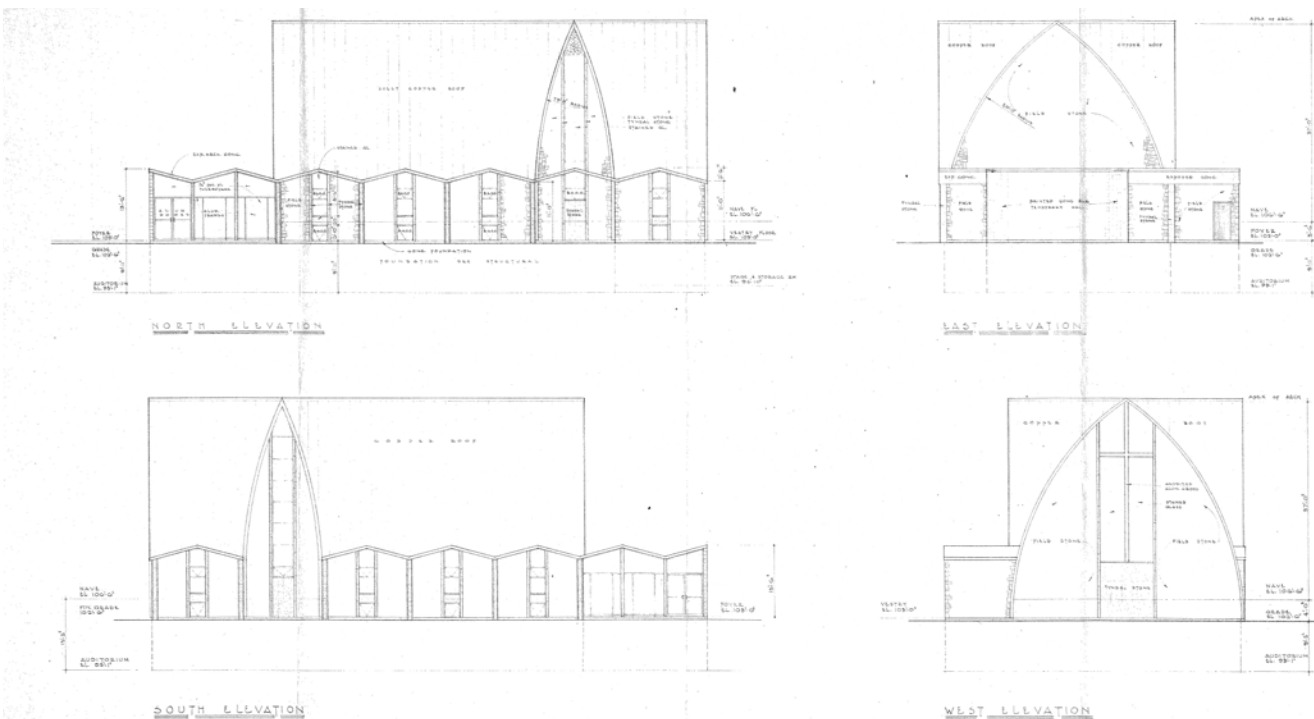

Figure 8. Building elevations. Retrieved from Facilities Management Division Asset Record System, File EC-24-T.

2.2 Form & Style

This building is modern in its form and detail, but it pays clear tribute to both the Collegiate Gothic context of the university and its mediaeval Gothic antecedents in the Christian architectural tradition. The roof of the nave, which creates the dominant form of the building, is composed of two pointed vaults intersecting in plan to form a cruciform, a device common to most Christian churches of the Middle Ages. The chapel has a broader vault running east-west, intersected by a narrower north-south vault. Figure 6 shows the intersection of the two volumes. This church differs from standard Gothic precedent in that its nave faces west rather than east. A smaller zigzag concrete slab makes up the roof of the entrance vestibule at the east end of the building. Its zigzag roof line extends across the north and south elevations of the main body of the chapel, forming the eaves of the copper roof (Figure 7). The extension of material planes and forms into one another is a common characteristic of Modern architecture. Although the building is predominantly symmetrical in form, a subtle asymmetry exists in the relationship between the lower entrance vestibule volume and the main volume of the chapel. Figure 8 shows this asymmetry in elevation. The form of the building, a hybrid between the modern and gothic styles, is a character-defining element that has fully maintained its commemorative integrity.

The chapel is characteristic of the modern period in its simplified ornamentation. In the case of this building, form is often used as ornament; the zigzag vestibule roof is an example. The building form itself consists of two exaggerated intersecting pointed vaults. The pointed arch is a Gothic element, but its application is Modern. Here, the traditional Gothic ribbed vault takes the Modern form of a series of glue-laminated wood arches. The vaults are punctuated only by windows and their structural ribs, and feature no decorative details. Notably, the windows of the nave feature triangular arches; a Modern interpretation of the Gothic arched window. These windows are shown in Figure 9.

In these ways, this Modern chapel pays tribute to both its Collegiate Gothic context at the University of Saskatchewan and its Gothic predecessors of Christian tradition. Its inventive mixture of Modern and Gothic, its use of exaggerated form as ornamentation and its rich material qualities mark it as an important work of architecture.



Figure 9. This window is modern in style but its peak pays tribute to the gothic style.

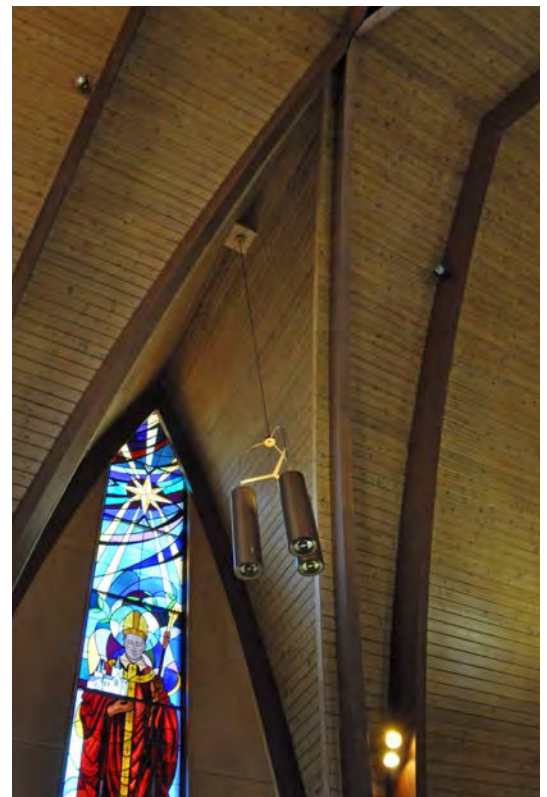

Figure 10. The nave features lancet windows and gothic arches formed by exposed decorative ribs.

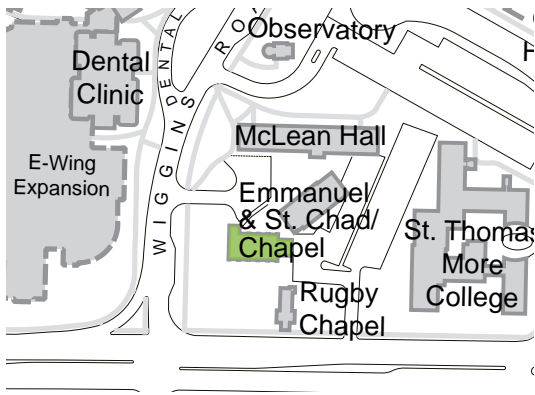

Figure 11. The location of the College of Emmanuel and St. Chad Chapel is indicated in green on this contemporary campus map. McLean Hall, Rugby chapel and the College of Emmanuel and St. Chad are all located nearby.

2.3 Location

The chapel is located east of the Wiggins Avenue entrance to the University of Saskatchewan's main campus. The nave of the building faces directly west. The chapel is also located adjacent to other Emmanuel and St. Chad College buildings. Figure 11 shows the location of the building in green creating an outdoor quadrangle between the [College of Emmanuel and St. Chad Building](#) and McLean Hall. Rugby Chapel is located near the southeast corner of the Emmanuel and St. Chad Chapel.

Through proximity, this location signifies an affiliation with the other former Emmanuel and St. Chad buildings.

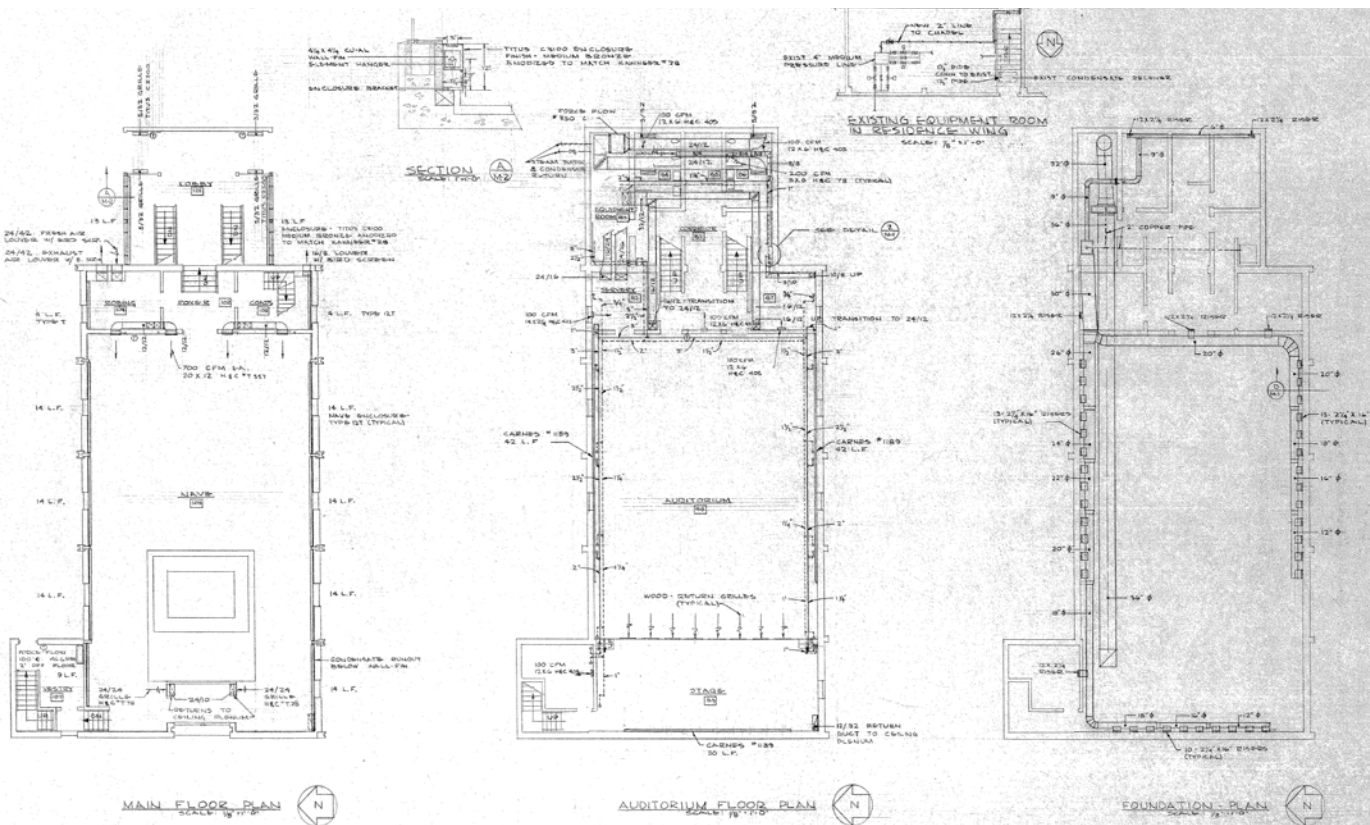

Figure 12. The floor plan of the College of Emmanuel and St. Chad Chapel. North is to the left. Retrieved from Facilities Management Division Asset Record System, File EC-32-T.

2.4 Spatial Configuration

The spatial configuration of the chapel has been largely maintained. The layout is a character-defining element as the floor plan and defines the building's identity as a Christian chapel. Figure 12 shows the building's floor plan; the primary space on the ground floor is the nave. The high, arched ceiling allows the choir loft to overlook the open nave. The spacious nave has largely maintained its commemorative integrity through the maintenance of its vaulted ceiling.



Figure 13. Light fixtures in the chapel's nave.

The altar and stage at the head of the nave has now been replaced with a small servery. To accommodate the use of the building as the Graduate Students Association Commons, two offices have been added flanking the entrance to the nave. Figure 14 shows the floor plan of the building's main space as it now exists.

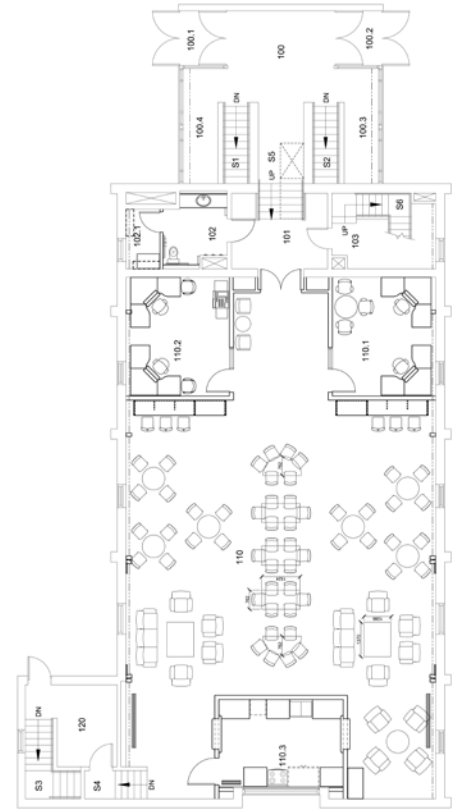

Figure 14. The current ground floor plan of Emmanuel Chapel. North is to the left. Retrieved from Facilities Management Division Asset Record System, File EC-936-130-T.

2.5 Systems

The exterior walls of the chapel consist of cast in place concrete faced in stone. The vaulted roof of the chapel, seen under construction in Figure 15, is supported by large wooden glue-laminated arched beams which are exposed on the interior. These arched beams support fir roof decking which is similarly exposed on the interior. The glue laminated arches carry the load of the building down to its concrete foundation walls. The structural system holds heritage and architectural value because of the vaulted form it creates and because of the aesthetic qualities of its exposed materials.



Figure 15. Emmanuel and St. Chad Chapel under construction in 1966. Photo A-346, retrieved from http://scaa.sk.ca/gallery/uofs_buildings/



Figure 17. The space being used by the Graduate Students Association.



Figure 18. An association with St. Chad College built into the North facing glass.

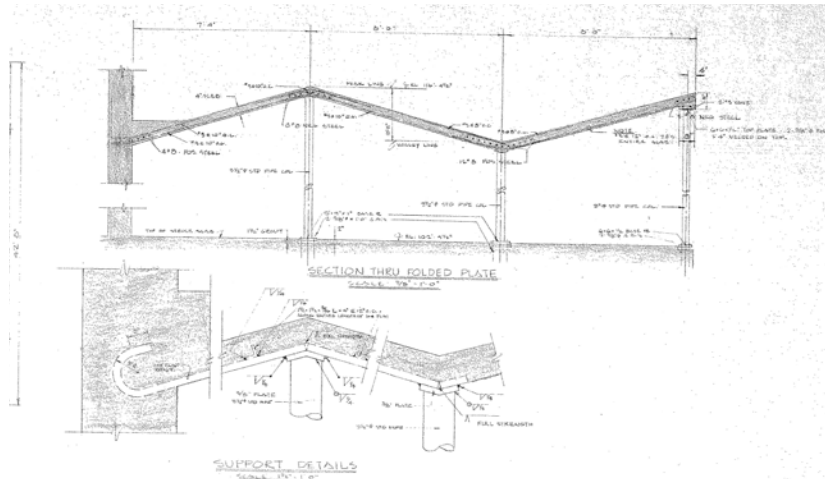

Figure 16. Roof details. Retrieved from Facilities Management Division Asset Record System, File EC-35-T.

Figure 16 shows the structural system supporting the entrance vestibule roof. The zigzag roof is composed of a concrete slab supported at its peaks and valleys by tubular steel columns. The glass foyer is enclosed by an aluminum-framed glazing system. The ground floor is a structural concrete slab and the building itself rests on cast in place concrete foundation walls and footings.

2.6 Use(s)

Prior to 1966, [Rugby Chapel](#) had served as the main chapel for Emmanuel College. The Colleges of Emmanuel and St. Chad amalgamated in 1964 and with the opening of the Emmanuel and St. Chad Chapel in 1966, the role of the Rugby Chapel was reduced. Emmanuel and St. Chad Chapel provided a 120-seat chapel, a reading room, library and offices for a university chaplain and two faculty members. The Anglican chapel was used as a meeting place and a place of worship. Births, graduations, weddings and funerals were held there. The Emmanuel and St. Chad Chapel was used in its original capacity until June 14, 2006 when a service to ‘deconsecrate’ the space was held.

The Emmanuel and St. Chad College Chapel remains defined as a chapel only through its form and style. The theological function of the building is no longer carried out and the space now functions as an office and social lounge for the University of Saskatchewan Graduate Students’ Association. The nave of the chapel is now a large open lounge with tables and chairs (Figure 14). The choir loft is an unused space and the basement accommodates washrooms and storage. The current use of the building thus does not carry any heritage value, but the building’s character-defining form is a reminder of its former use. Figure 17 depicts the space in its current configuration and use.

2.7 Cultural & Chronological Associations

The chapel still carries association with the Colleges of Emmanuel and St. Chad despite their discontinued use of the building. The stained glass windows in particular are character-defining elements associating the building with the theological colleges (Figures 17-20). The windows have heritage value and commemorative integrity. The two large stained glass windows on either side of the nave display the names of the Colleges, shown in Figures 18 and 19.

The central stained glass window overlooking the nave from the head of the space chronologically associates the building with the Modern era. The principle window depicts steamships and airplanes as well as wheat being harvested by scythe. The construction of the servery at the head of the nave has obscured some of this imagery. Figure 20 shows the largest stained glass panel located above the former location of the altar.

The most obvious cultural association that this building holds is its affiliation as a religious institution. Elements that define the building as Christian saturate the building: stained glass panels depicting biblical scenes and symbols, light fixtures with Christian symbolism, the arched form of the building and its spatial configuration with a nave and a choir loft all classify the building as a church. The central stained window also depicts scenes of divine creation and human industry. The window illustrates the heavens, planets and plant life as examples of God's creations. Human creations are represented through steamships, and airplanes. Agricultural scenes represent the shared efforts of God and humanity.



Figure 21. Christian references are still found in many elements that define the character of the interior.

Despite the change in use it has undergone, the commemorative integrity has been maintained to a high degree through the maintenance of these numerous character-defining elements. Some of these elements are displayed in Figures 20 and 21.



Figure 19. Emmanuel College is commemorated in the south facing window.



Figure 20. The central stained glass window depicts the creative works of man and God.

3. Associated Objects

N/A

4. Supporting Documents

Author Unknown. (April 29, 2005). College of Emmanuel & St. Chad likely to close. *On Campus News*, 12. Retrieved from <http://www.usask.ca/communications/ocn/o5-apr-29/news03.shtml>.

Facilities Management Division (2011). Asset Resource Database [Data File]. Retrieved from \\usask\fmddfs\files\iis\IIS_Public\ARS

Macdonald, R.H. (1965, December 2). WP Photographcolor Section. *The Western Producer*, pp. C1.

Richards, B. (January 8, 2010). Viewpoint: Use may change but memories remain. *On Campus News*. Retrieved from <http://news.usask.ca/archived/ocn/10-jan-08/viewpoint.php>

Saskatchewan Archives Board. Call no. B124 AII.124-125.

University of Saskatchewan Archives. (Retrieved 2011). *Campus Buildings: Emmanuel College/Rugby Chapel*. Retrieved from http://scaa.sk.ca/gallery/uofs_buildings/.



5. Summary of Character - Defining Elements

Materials

- standing seam copper roof
- 'greystone' walls
- tyndall stone trim
- stained glass windows
- fir (glue-laminated arches, decking)
- oak paneling
- terrazzo floors

Form & Style

- intersecting pointed vaults
- zigzag concrete slab roof
- triangular arched windows

Location

- adjacent to other Emmanuel and St. Chad College buildings
- creation of outdoor quadrangle between the College of Emmanuel and St. Chad buildings

Spatial Configuration

- choir loft
- high vaulted nave ceiling

Systems

- arched glue-laminated beams

Uses

- theological education
- worship
- lounge

Cultural & Chronological Associations

- Emmanuel College stained glass window
- St. Chad College stained glass window
- central stained glass window
- Christian symbols (Christ symbol on windows, Christian symbols on large windows)

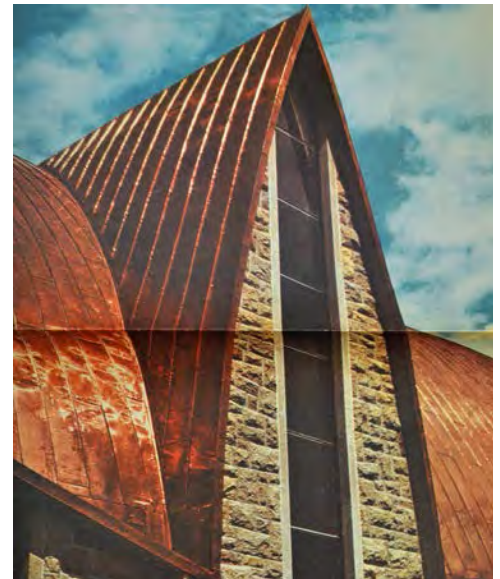

938 - 940

Lutheran Seminary



938 - 940

Lutheran Seminary

Alternate Names

**Lutheran Theological Seminary
LTS**

Architect(s)

J. Holliday-Scott and M. Desmond Paine Architects, Saskatoon

Builders

Wells Construction Company

Construction Dates

1968

Recognition

University of Saskatchewan 'A' Listed

1. Statement of Significance

Lutheran Theological Seminary (LTS) is a theological college affiliated with the University of Saskatchewan and located at the north-west corner of the campus, on a site overlooking the South Saskatchewan River. Prior to 1968, the Evangelical Lutheran Synod of Manitoba and Other Provinces and the Norwegian Lutheran Church in America each maintained a separate theological school in Saskatoon. A merger of the two schools occurred in 1965, forming the Lutheran Theological Seminary, which provided impetus for the construction of the seminary complex. This report pertains to the group of three buildings forming the seminary: the Academic College Building, the Dean's Residence and the Student Residence.

The Lutheran Theological Seminary was designed by the firm J. Holliday-Scott, M. Desmond Paine Architects and was built in 1968. The seminary is a highly significant work of late-modern architecture by a particularly accomplished architect. In his design for the Lutheran Seminary, John Holliday-Scott adapted his own modernist impulse to the architectural traditions of the University of Saskatchewan and to an ancient building type with its own rich history, producing an elegant and multi-layered building.

Note: The floor numbering convention used in this building is: ground floor, first floor, second floor etc... This convention is followed in this report.



Figure 1. 'Dry stone wall' composed of greystone.

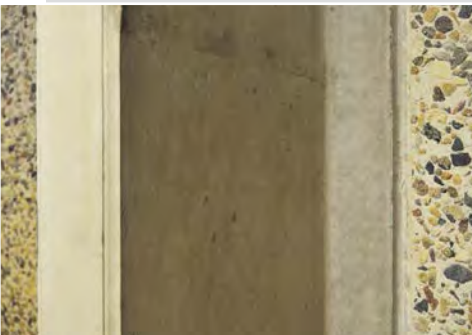

Figure 2. Smooth and exposed aggregate concrete finishes.

2. Character - Defining Elements

2.1 Materials

The exterior elevations of the Lutheran Seminary buildings are composed of a combination of the rough-faced greystone used for earlier university buildings and exposed precast concrete. The Academic College Building consists of three connected volumes: a double-height chapel on the east side, a two-storey library on the west side, and a central wing containing the entrance lobby on the first floor and administrative offices on the second floor. The exterior of the chapel is enclosed completely in greystone. The base of the entrance wing and library are also constructed of greystone. This greystone base wraps around the building and extends to form the walls of the courtyard on the west side, the Dean's residence and the student dormitories. The greystone on this building is a rough-faced fieldstone, laid up in an uncoursed bond pattern, with raked mortar joints made to resemble a mortarless 'drystone' wall (Figure 1). The stone is in excellent condition. (For further information on building stones used at the U of S, refer to ['Appendix: Stone.'](#))

The walls of the library are constructed of precast concrete T-section panels, oriented vertically. The concrete panels have an exposed aggregate finish, except for their vertical fins, which are smooth (Figure 2). The repetition of the fins across the elevation and the alternating pattern of smooth and exposed-aggregate concrete, gives the impression of a colonnade. On the Dean's residence and student dormitories, walls are in greystone, smooth concrete is used to express horizontal floor and roof plates, while the exposed-aggregate concrete forms spandrel panels. The Dean's residence and student dormitories both feature exaggerated roof projections in the form of smooth-finished precast concrete beams and slabs.



Figure 6. Academic College Building. Photo CP-5925-B-3, retrieved from <http://spldatabase.saskatoonlibrary.ca/>



Figure 3. Glazing in the foyer of the Academic College Building.



Figure 4. Stainless steel framed clerestory glazing on a painted, ribbed concrete wall.

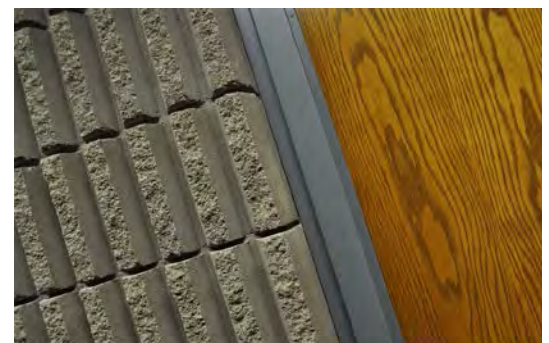

Figure 5. L to R: Split-faced, ribbed concrete block, oak door.

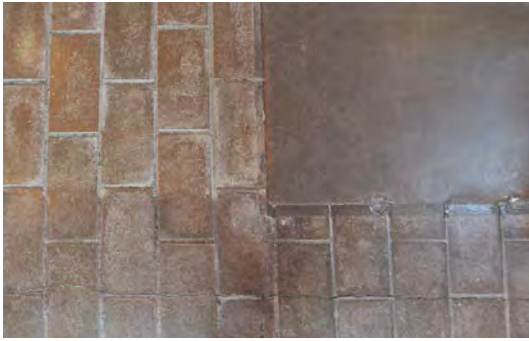

Figure 7. Brown terra cotta tile floor.



Figure 8. Stainless steel light fixture in front of painted concrete block wall.



Figure 9. Oak window frame, edged in steel and detailed as a discrete entity.

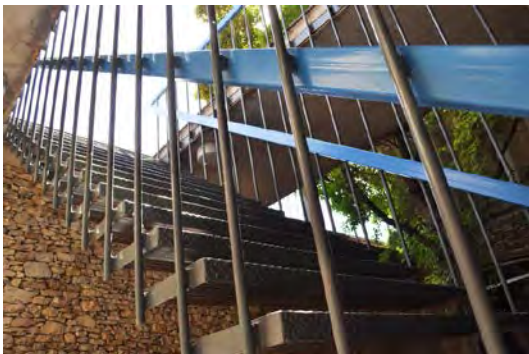

Figure 10. Steel balustrade.

Aluminum and steel-framed glazing is another character-defining material. Floor-to-ceiling glazing is used to distinguish entries, circulation and common spaces in the Academic College Building (Figure 3). Skylights illuminate the chapel, library and central stair.

Interior areas are characterized by concrete in various different textures and finishes (Figures 2-6). The Academic College Building features a central staircase formed in concrete with a ribbed concrete balustrade (Figure 4). The ribbed concrete is painted. Unpainted concrete block with a similar ribbed profile and a rough texture is used on the corridor walls of the second floor offices (Figure 5). The same vertical precast concrete panels forming the exterior walls of the Academic College Building are also used on the interior of the chapel. The floors of the entrance lobby and the chapel are in a brown terra cotta tile (Figure 7). The interiors of the Student Residence consist of painted concrete block walls (Figure 8). These are also found in the Dean's Residence and sporadically throughout the Academic College. Concrete, in its various finishes, is a character-defining element of this grouping of buildings.

Millwork, doors, baseboards, wall cladding, window frames and surrounds are typically in oak, which is generally in good condition (Figures 5 & 9). Some of the oak doors of the student residence rooms have been resurfaced due to damage. The student residence rooms still retain their oak desks; the chapel has an oak altar, lectern and pews.

Steel is a commonly-used secondary material. Brushed stainless steel is used for light fixtures (Figure 8), edging along window surrounds (Figure 9), door hardware, and as the framing material for the glazed entrance doors and the door to the chapel. The library features a steel and oak balustrade. Painted steel balustrades and staircases are found on both the interior and exterior. The interior of the library features steel staircases, painted steel balustrades and a raised walkway. The painted and stainless steel fixtures are in excellent commemorative condition and are character-defining elements.

Architect John Holliday-Scott often accentuated his designs with bright accent colours. In the case of the Lutheran Seminary, the architect chose to highlight certain details in blue (Figure 10). The colour blue appears in numerous places throughout the complex, most commonly on balustrades and furnishings, and is a character-defining element.

All of the original materials and material finishes in the Lutheran Seminary are character-defining elements.

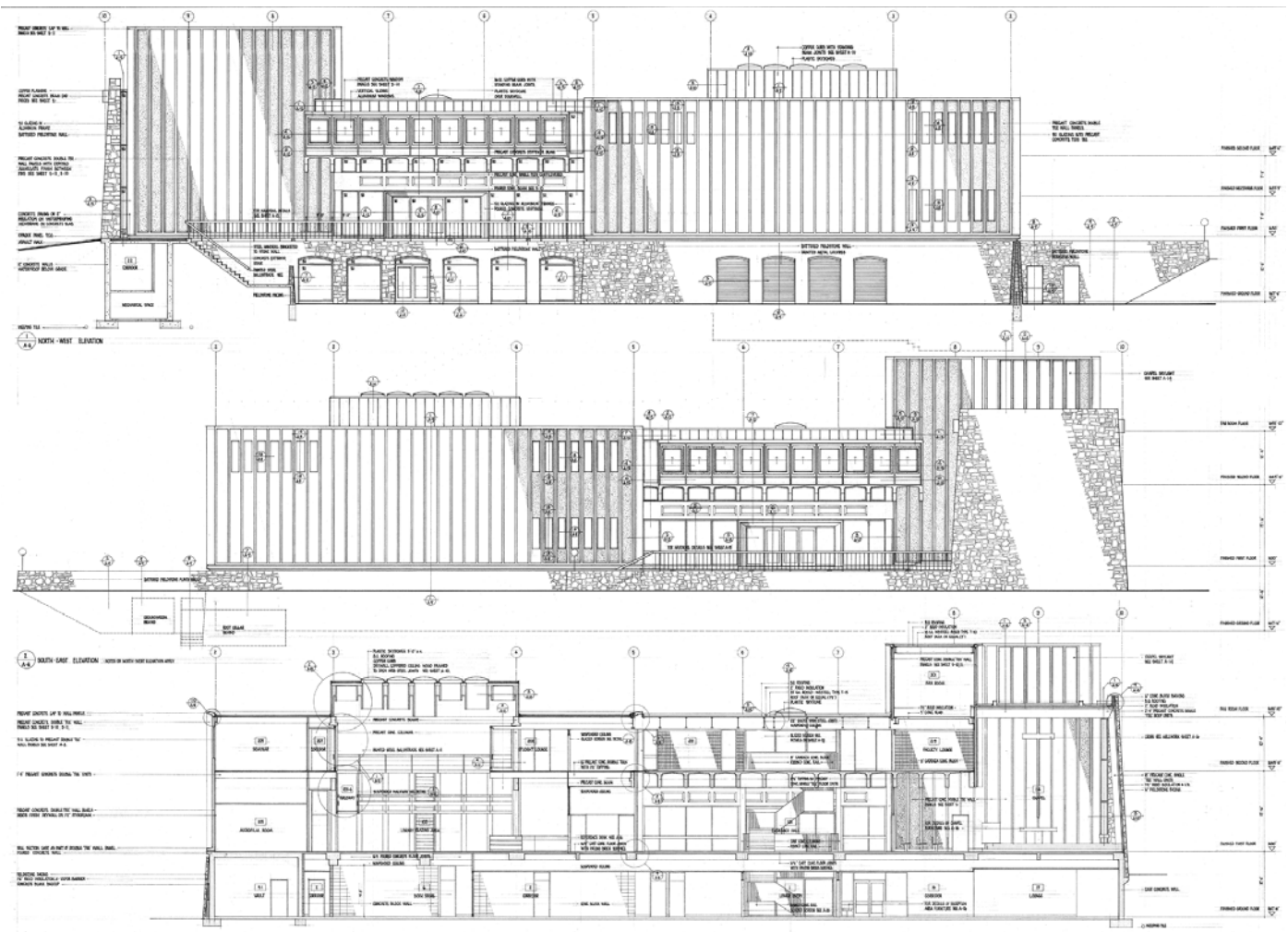

Figure 11. Elevations and section of the Academic College Building at the Lutheran Seminary. Retrieved from Facilities Management Division Asset Record System File 938-143-T.

2.2 Form & Style

The Lutheran Seminary is a beautiful example of late modern architecture, whose formal and stylistic expression, material characteristics and relationship to site form a coherent synthesis relating the contemporary practice of religious education to its long history.

By 1968, international architecture of the late modern period had reintroduced more representational forms and historical architectural themes to the earlier, more restrained manifestations of modernism. In all of his work at the University of Saskatchewan, John Holliday-Scott took full advantage of the context of the campus to explore and expand the expressive potential of its traditional materials and styles. In the Lutheran Seminary, Holliday-Scott added the traditions of monastic architecture to his list of precedents.



Figure 13. The cast concrete walls of the entrance vestibule penetrate an envelope of glass. The glazing lightly intersects with the concrete.



Figure 14. Precast concrete wall panels on the library.

The Lutheran Seminary takes as its point of departure traditions of monastic life and scholarship, and their corresponding architectural form, the cloister. The essential features of the cloister were the church and living quarters, arranged to form a protected courtyard. In the middle ages, the courtyard form provided a setting suited to study and contemplation, while offering a measure of protection from external threats. (See Section 2.4 Spatial Configuration.) The seminary has a more recent origin than the monastery, but as an architectural typology included the same general features. In the modern context, the creation of a quiet, inwardly-focused setting for religious instruction and study remained relevant. In the Lutheran Seminary, the courtyard is enclosed on only three sides; on its north side it opens out towards the natural setting of the riverbank.

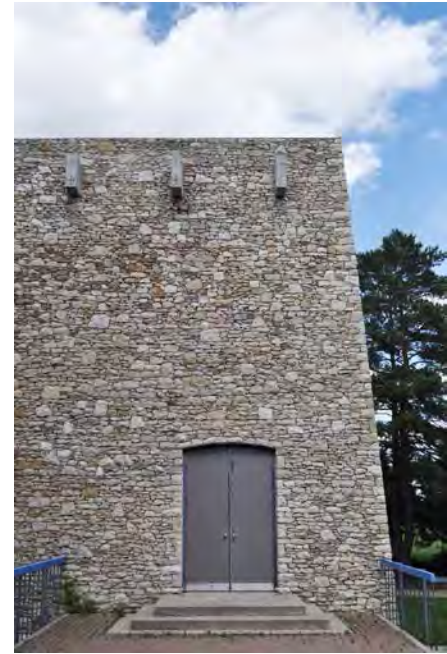

Figure 12. Chapel walls.

Just as the courtyard form of the Lutheran Seminary was drawn from an ancient tradition but rendered in a modern idiom, Holliday-Scott seamlessly blends modernist and traditional architectural expressions throughout the building. The various functions of the functional program - a chapel, library, Dean's residence and student dormitories - are expressed in the modernist manner as distinct parts. That expression of function is reinforced by Holliday-Scott's use of materials. For example, the traditional material of greystone is used in the cladding of the chapel in a modern way, to define that function as its own discreet form, separate from the other parts of the building (Figure 12). The characteristics of materials are used to reinforce this expression of separate elements; glazing is detailed so as to 'disappear' into the surrounding stone giving the impression of two materials intersecting. Interior oak window frames project from the plane of the wall to look like discrete volumes (Figure 9). At the main entrance, the vestibule is expressed as a concrete box, which appears to intersect the plane of the glazed wall (Figure 13).

The expressive use of structure is another hallmark of modernist architecture, but here again this use is complex and often layered with references to the past. For example, the precast concrete wall panels on the library wing, which are a characteristic material of the modern period, are expressed with a strong verticality, in a subtle reference to the gothic traditions of the wider campus (Figure 14).

The stone walls of the chapel and the base of the Academic College Building are slightly canted, giving them the appearance of solidity and implying a load-bearing function. Arched openings in these stone walls recall traditional masonry details (Figure 15). However, upon entering the chapel, it is revealed that the walls are in fact tilted inwards to achieve this effect, and that a row of precast concrete panels forms the supporting structure (Figure 16). The ribs of the precast panels may also be seen as a modern representation of the ribbed vaulted ceilings of a gothic cathedral.

On the east and west sides of the chapel, a row of concrete beam ends project along the top of the stone walls. These projections express on the exterior of the chapel the precast concrete beams that form its roof structure. However, they also make reference to triglyphs, a decorative device from the classical architecture of ancient Greece and Rome. In the architecture of the Greek temple, triglyphs were the stone expression of wooden beam ends that would have supported the temple roof. Figures 17 and 18 compare the concrete details of the Lutheran Seminary with their ancient Greek precedent.

Other expressions of structural elements are unequivocally modern. On both the exterior and interior, precast concrete beams and roof slabs are cantilevered to form overhangs and to support projecting spaces (Figures 19 & 20). Precast concrete T's



Figure 15. Canted stone wall with arched window openings.



Figure 17. Concrete beam ends on the chapel walls.



Figure 16. The nave of the chapel: exposed concrete structure and canted walls recall ribbed vaulting.

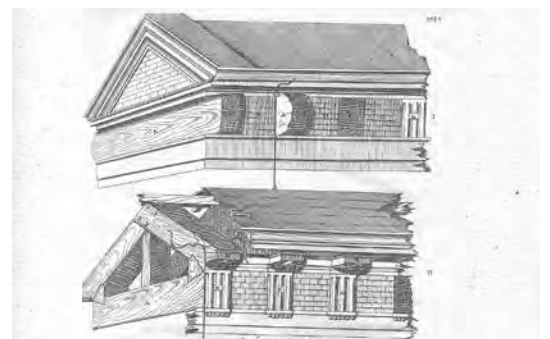

Figure 18. The origin of the triglyph. Retrieved from <http://blogs.nd.edu/classicalarch/files/2012/07/Origin-of-the-Triglyph-1700-Dutch2.jpg>



Figure 20. A stair pierces the bridge to the first floor entrance.



Figure 21. Suspended stair in the General Motors Technical Centre in Detroit. Photo retrieved from <http://www.autofieldguide.com/blog/post/vintage-design-lives>

forming the floor structures of the building are exposed as finished ceilings in the entrance lobby, the chapel and the library. At the main entrance, the front doors are reached over a concrete bridge spanning a light well (Figure 20). The centre of the bridge is punctured by an open staircase that offers access to the level below. The open treads of the stair are suspended from the concrete bridge deck by steel tension rods, with a detail similar to that used by Holliday-Scott in both the [Law](#) and [Dentistry](#) buildings. The stair recalls the earlier modernist precedent of the suspended stair in Eero Saarinen's General Motors Technical Center in Detroit (1949-55) (Figure 21).



Figure 19. The Student Residence.

2.3 Location

The three buildings of the seminary complex are set on the bluffs on the south-east side of the South Saskatchewan River. They are arranged, in conjunction with a series of stone walls, to form a courtyard, open to the river but enclosed to the south, east and west. The location and setting of the buildings, their relationship to the river and their corresponding cloistered form, are all important aspects of the architectural response to the building program. The buildings form a protected and contemplative environment, in a peaceful location and a beautiful natural setting, all perfectly suited to religious study and prayer.

The choice of location for the Lutheran Theological Seminary was a difficult decision made following the merger of the Lutheran Theological Seminary and the Lutheran College and Seminary. Prior to this unification, the Lutheran College and Seminary had been located on a small campus on Eighth Street, which included student accommodation for married couples. The Luther College Buildings on Wiggins Avenue, directly across College Drive from the University of Saskatchewan campus, provided accommodation for single students (Hordern, 1994). With the merger of the two schools, the issue of where to locate the 'new' theological institution became a point of debate. Three options were vetted: the Eighth Street East location, the Wiggins Avenue location or a new location on the University of Saskatchewan campus. The Board of the Lutheran Seminary initially hoped for a location near the other affiliated theological colleges of [St. Andrew's](#), [Emmanuel](#) and [St. Chad](#) and [St. Thomas More](#); however, no site large enough was available. Instead, it was recommended that the Seminary locate in a 'new' residence area, in the north-west part of the campus. This location, unchanged since 1968, is shown in Figure 22.

2.4 Spatial Configuration

As discussed earlier, the Lutheran Seminary is designed as a modern interpretation of a cloister. The cloister of the middle ages included a church and a dormitory, arranged to enclose a courtyard with an arcaded periphery (Kostof, 1985). Kirkstall Abbey in Yorkshire is a useful precedent for comparison (Figure 23). Although the site plan of the Lutheran Seminary is more open than that of Kirkstall, a shared courtyard unifies both designs in a similar way. Many of the functions of the buildings of the Lutheran Seminary descend directly from those of its predecessors; a church and dormitories are still important components of the plan. Whereas the traditional cloister was generally enclosed on all four sides, the courtyard of the Lutheran Seminary is enclosed on three sides, but left open towards the river.

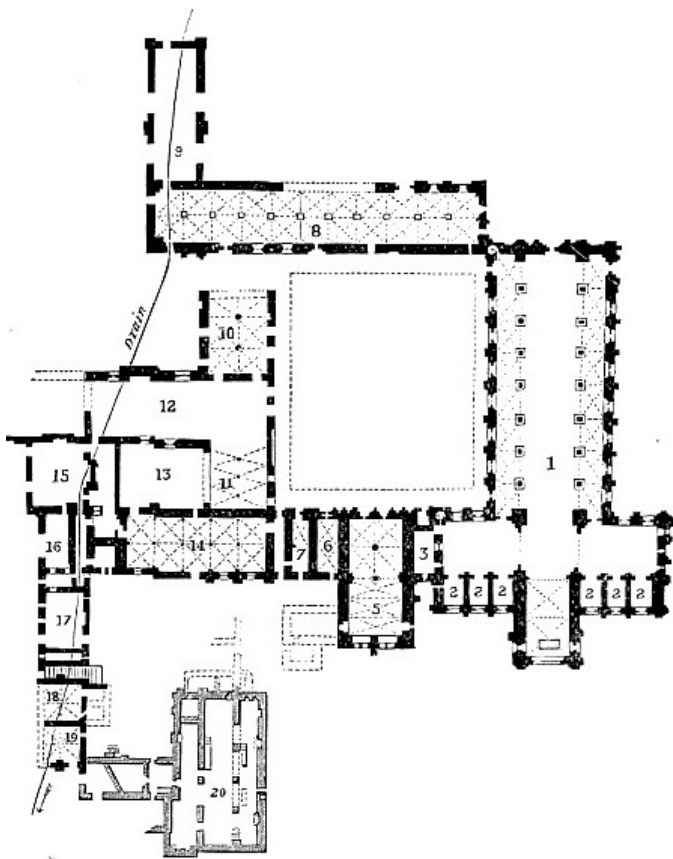

Figure 23. Site plan of Kirkstall Abbey, Yorkshire. This Cistercian abbey consists of: 1. Church 2. Chapels 3. Sacristy 4. Cloister 5. Chapter House 6. Parlour 7. Punishment Cell 8. Cellars with Dormitories for Conversi over 9. Guest House 10. Common Room 11. Old Refectory 12. New Refectory 13. Kitchen Court 14. Day Room 15. Kitchen and Offices 16-19. Uncertain 20. Infirmary or Abbot's House. Retrieved from <http://www.1902encyclopedia.com/A/ABB/abbey-13.html>

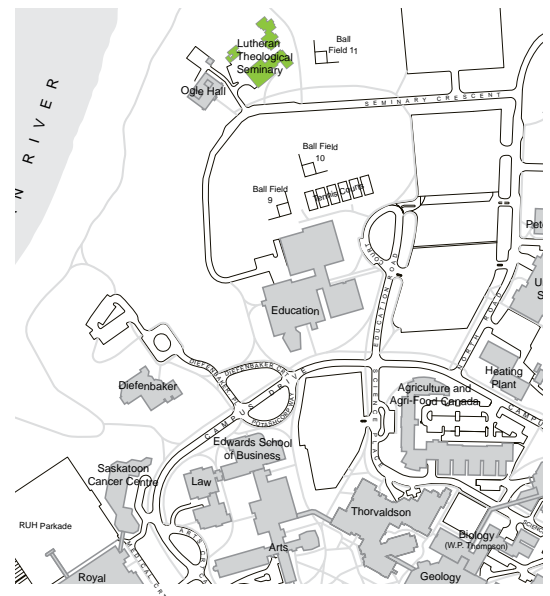

Figure 22. The location of LTS is indicated in green on this contemporary campus map.

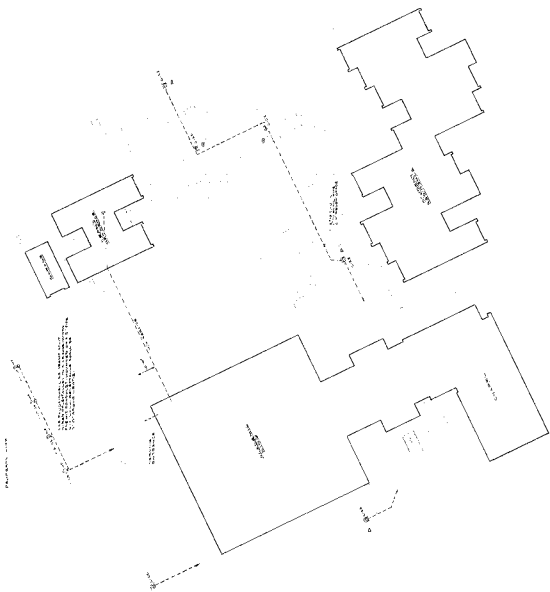

Figure 24. Site plan of the Lutheran Seminary group of buildings. Retrieved from Facilities Management Division Asset Record System, File 983-89-T.

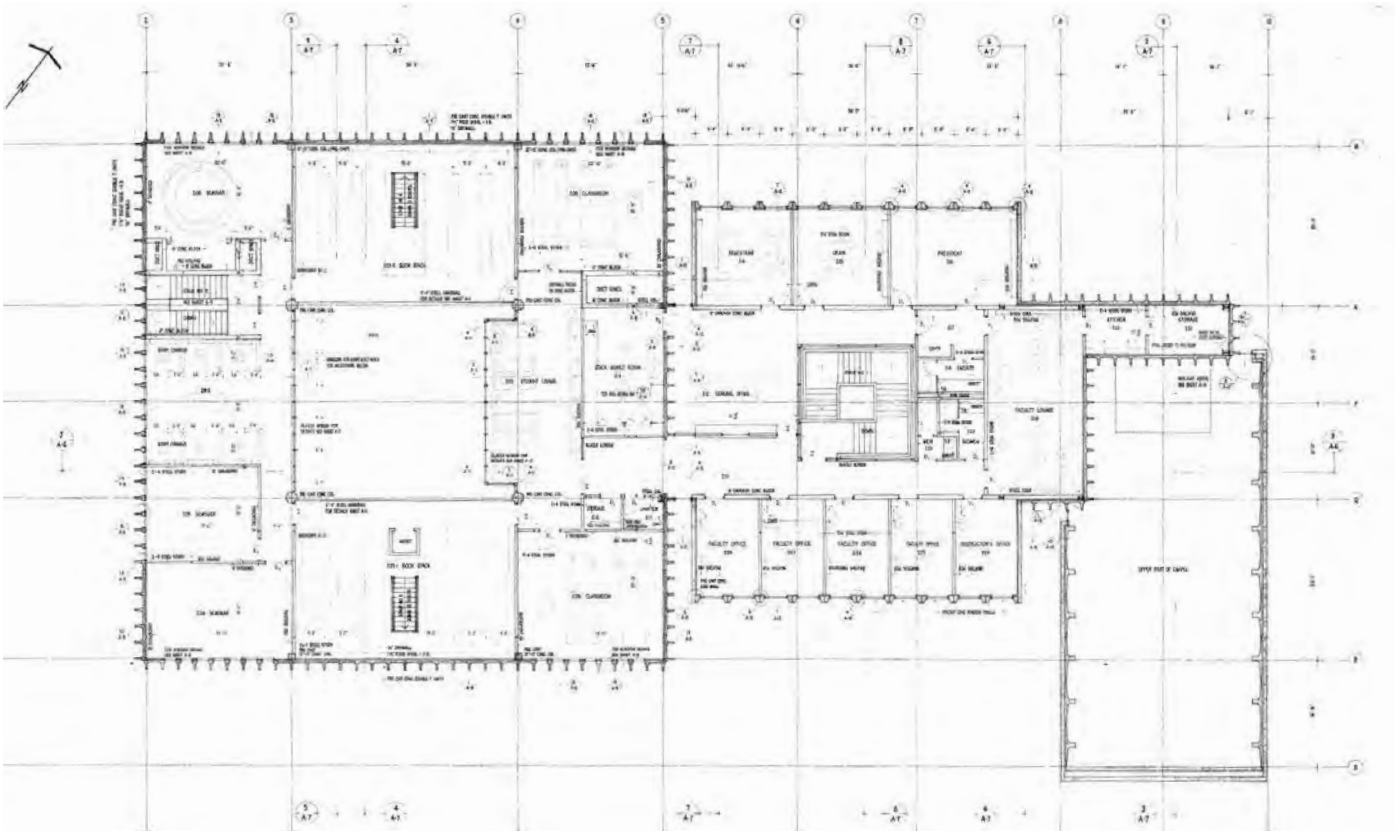
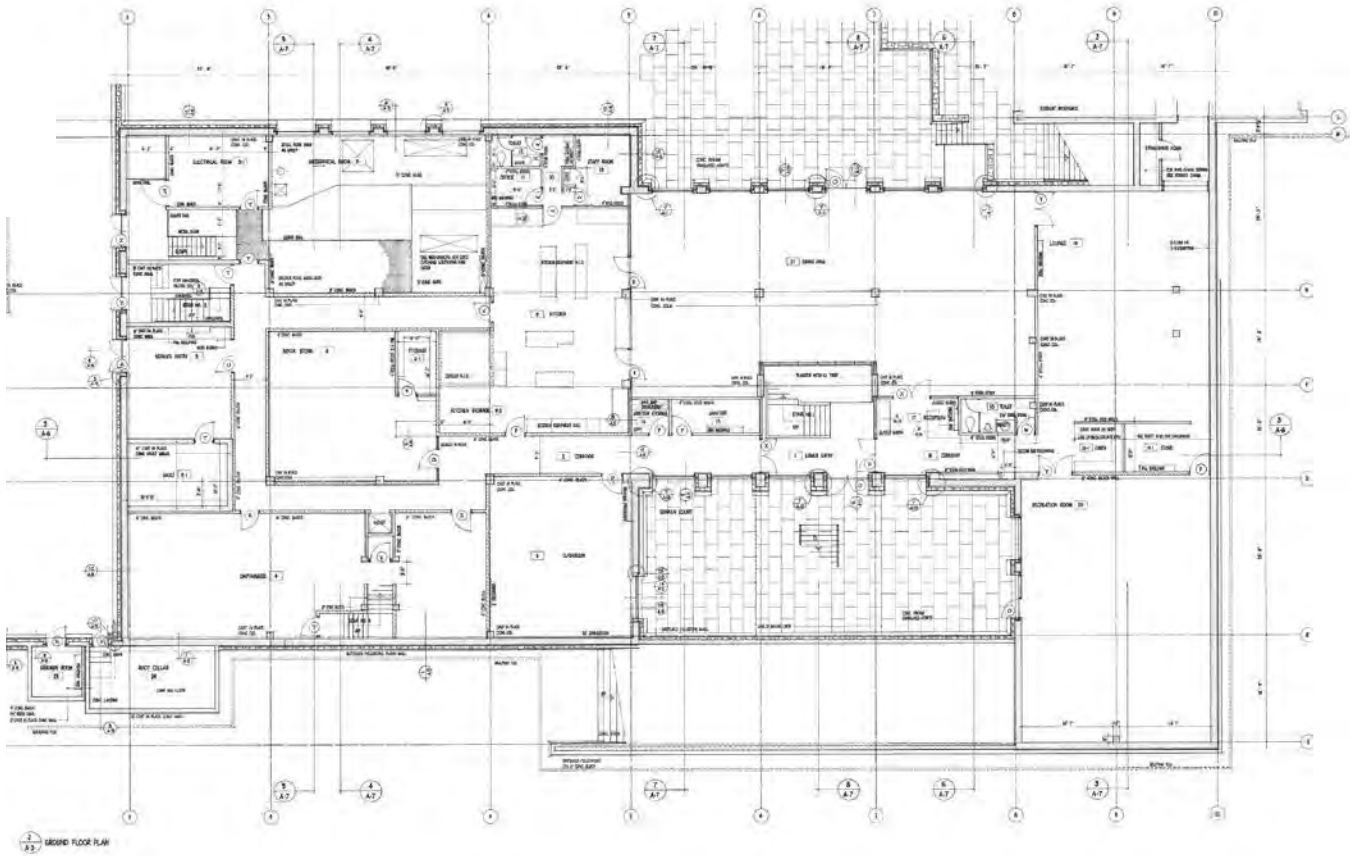

Figure 25. Top to Bottom: Ground and second floor plans of the Academic College Building. Retrieved from Facilities Management Division Asset Record System, Files 983-146-T, 938-144-T.

The Academic College Building in the Lutheran Seminary is composed of three major functional spaces: a chapel, a library and a central foyer and administrative area. The entrance and administrative wing serves to connect the larger volumes of the library and chapel.

The chapel is an austere but beautiful space. It is laid out in the traditional manner, with a nave, a central aisle, an apse and a choir, except that the entrance is incorporated into a transept on the west side. The chapel is a tall space, about 26 feet in height, and the floor is slightly raked. The wall and roof structures of the chapel are formed from a series of precast concrete T-shaped panels. The walls are slightly inclined, and their precast panels are exposed on the inside surface of the room, such that the fins of the panels form a row of vertical elements, like a row of columns. At the north end of the central aisle, the apse is bathed in natural light from a skylight (Figure 26). The skylight washes the adjacent wall, highlighting the contrasting textures of the rough exposed aggregate of the wall panels and the smooth concrete of their vertical fins. Aside from the skylight, very little natural light enters the space. The acoustic quality of the space is particularly striking – small sounds are amplified by the echo in the room, very much like a stone church of the middle ages. The chapel is well-suited to musical performance and is often used by music students. The height of the space, the skylight and the configuration of its nave, transept and apse are all character-defining elements.

A hallmark of the work of John Holliday-Scott was to incorporate a soaring central space as a focal point, around which the rest of the building was organised. The main reading room fulfills this function in the library of the Lutheran Seminary. The library is square in plan, 80 x 80 feet in dimension. A double-height central reading room on the first floor forms its core. Classrooms, seminar rooms, study carrels and support services are arranged around the perimeter of the first floor reading room and on the second floor, overlooking the main reading room. A second floor seating area projects out into the space of the library atrium (Figure 27). Book stacks are arranged on three levels, compressed into the vertical dimension of the two adjacent floors. Open steel staircases provide access between the book stack levels, and a bridge spans the open space between the two book stack mezzanines. In the ceiling of the reading room, a series of acrylic dome skylights and light wells illuminate the space. The only change to the spatial configuration of the library has been the addition of a second elevator shaft.

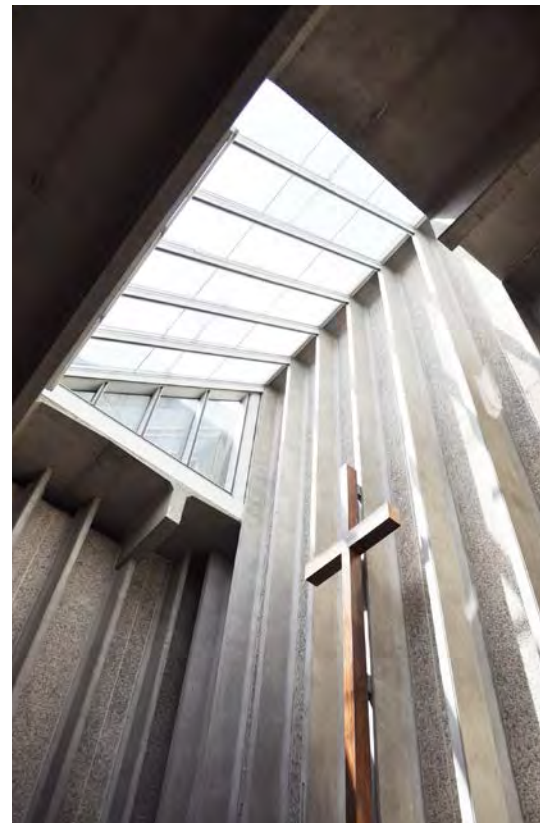

Figure 26. Chapel skylight.



Figure 27. Skylights above a glazed seating area into the Lutheran Seminary library.



Figure 28. Raised walkway in the Lutheran Seminary library.

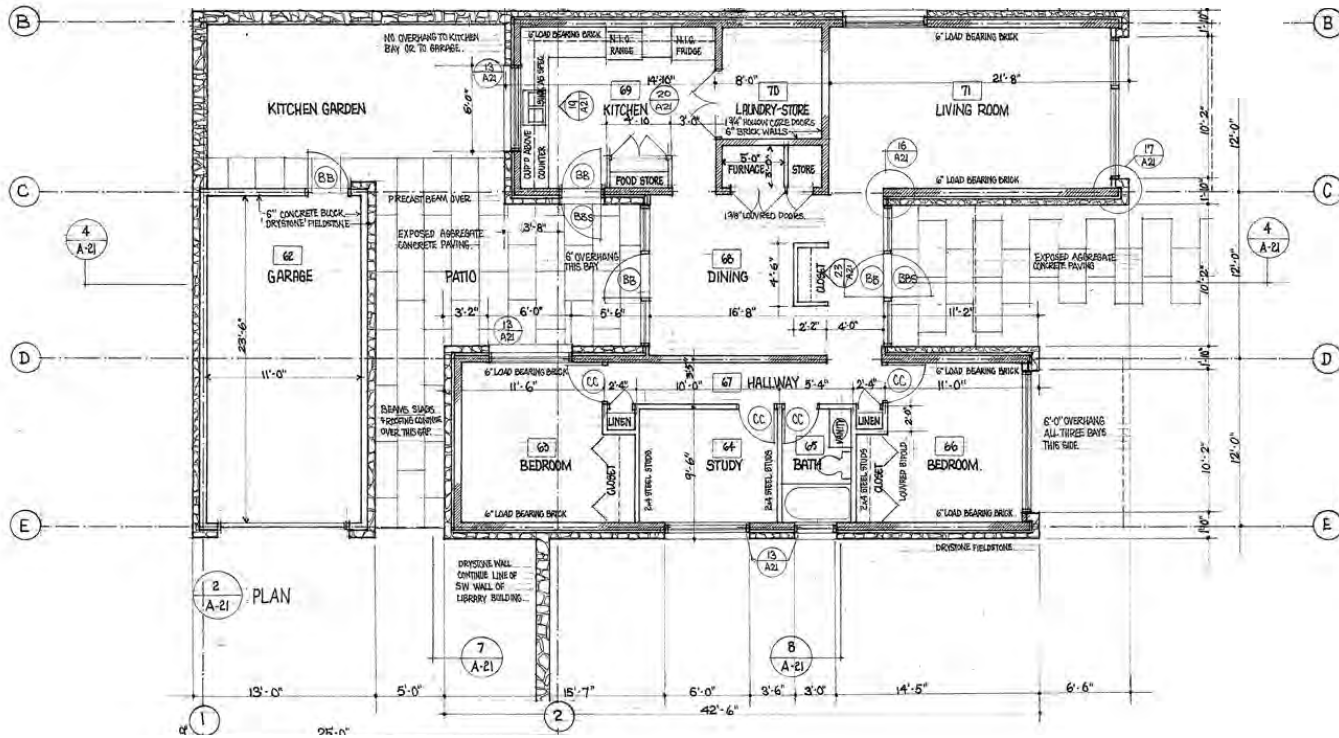

Figure 29. Floor plans for the Dean's Residence. Retrieved from Facilities Management Division Asset Record System, File 983-128-T.



Figure 30. The Dean's Residence.

The Dean's Residence, originally a private house for the Dean of the seminary, has been converted into residence accommodation for multiple students. Originally, this was a simple single-story dwelling in the modernist style. The house was arranged in plan as three connected wings. The north wing consisted of a kitchen, laundry room and living room. The south wing contained two bedrooms and a small study. The north and south wings were connected by a central wing consisting of an entrance foyer and a dining room. A covered outdoor patio led off the dining room to the west, and connected to a garage. A small courtyard, enclosed by stone walls, provided a private outdoor space adjacent to the kitchen. Formally, the north and south wings of the Dean's residence are conceived of as discrete volumes, wrapped by stone walls. The central entrance and dining wing is predominantly glazed, and forms a lighter connective element between the living and sleeping wings (Figure 29).

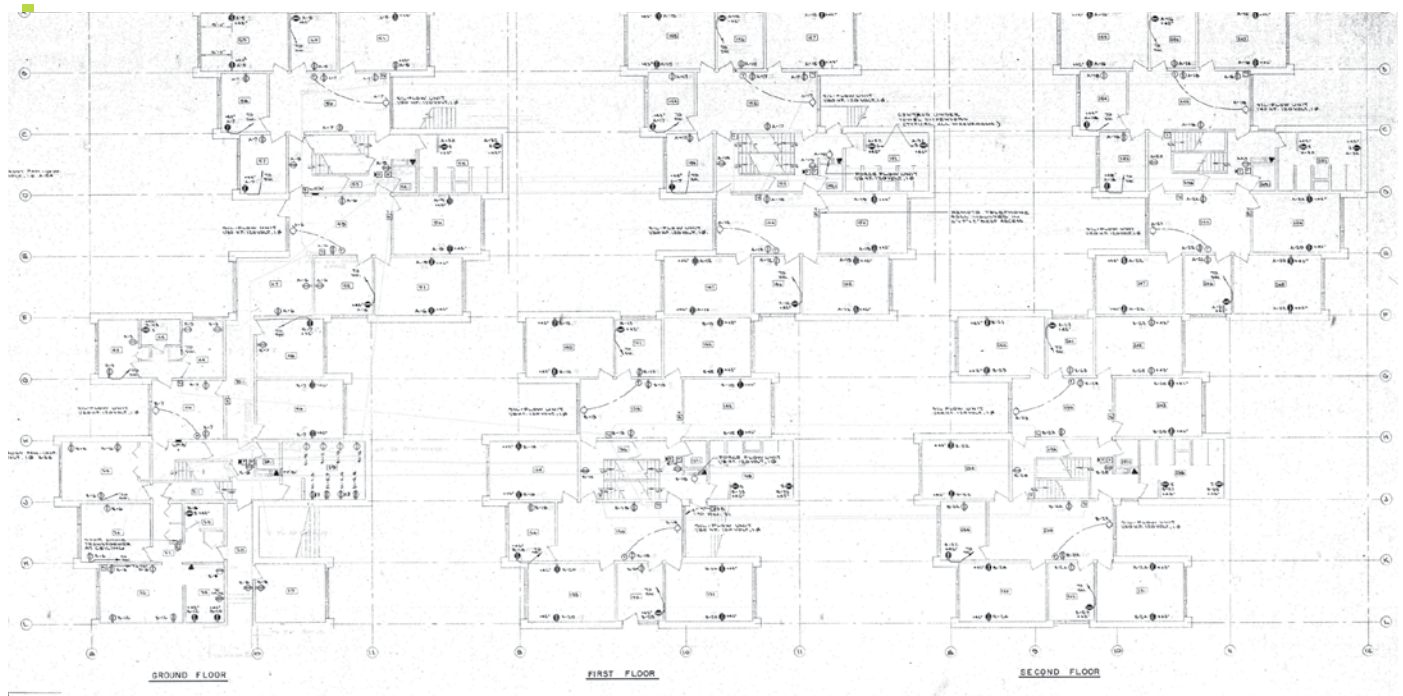

Figure 31. Floor plans for the Student Residence Building. Retrieved from Facilities Management Division Asset Record System, File 983-83-T.

The Student Residence Building is configured on each of its three floors as two clusters of dormitory rooms, each arranged around a central stair and two common lounges spaces. The lounges unify the residence rooms much as the courtyard unifies the separate buildings of the larger seminary. The result is a series of ‘houses.’ The grammar school that architect John Holliday-Scott attended in England was divided into ‘houses,’ which influenced his thinking on the most effective arrangement of spaces to support collegiate life. It was this conviction that led him to arrange the rooms in groups or ‘families’ rather than in a linear fashion along corridors.

The dormitory rooms have large windows and the common lounges are glazed from floor to ceiling. Figure 31 shows the staggered arrangement of the rooms in plan, which allows for varying degrees of privacy. Those familiar with the Lutheran Seminary have come to refer to the southern half of the Student Residence Building as ‘Tower One’ and the northern half as ‘Tower Two.’ The two ‘halves’ of the building are connected only by the hallway on the ground floor. The central staircases in each cluster offer the only means of accessing the rooms above. The uppermost floor of the Residence Building features the high ceiling and clerestory windows that are also found in the Dean’s Building (Figure 32).



Figure 32. A residence room on the top floor.



Figure 33. The Lutheran Seminary under construction, April 18, 1968. Photo CP-5925-A-2, retrieved from <http://spldatabase.saskatoonlibrary.ca/csdata/images/lhr/web/cp/5000/cp-5925-A-2.jpg>

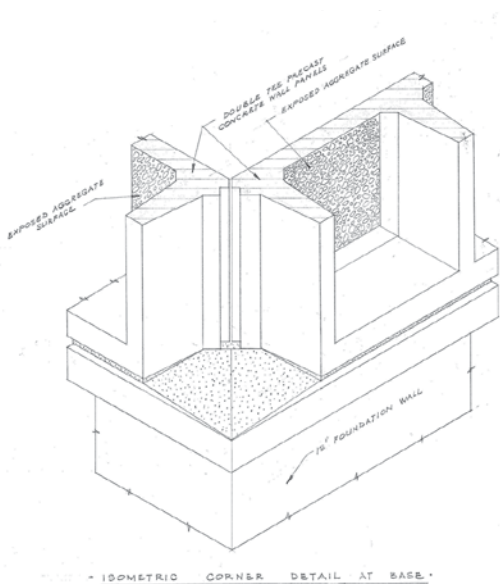

Figure 34. Concrete detailing. Retrieved from Facilities Management Division Asset Record System, File 938-114-T.

2.5 Systems

The Lutheran Seminary buildings combine two different principal structural systems for the Academic College Building and the two residential buildings, respectively. The Academic College Building is constructed with wall, floor and roof structures of precast concrete T-section panels. The floor and roof panels are supported on the interior of the building on a system of precast concrete beams and columns. On the chapel, both the wall and roof panels are exposed on the interior of the space. The walls are insulated and clad with fieldstone on the exterior. On the library and office wings, the concrete wall panels also form the exterior surface of the wall, and are insulated and finished with gypsum board on the interior. Foundation walls and footings are cast-in-place concrete. The Dean's Residence and Student Residence buildings are constructed with load-bearing walls. The drawings indicate 'cavity-walls' consisting of load-bearing brick, insulation and exterior stone cladding, but the brick appears to have been substituted with a scored concrete block, which is left exposed and painted on the interior. Floor structures are precast concrete panels with a poured concrete topping. The roofs of both the Dean's Residence and Student Residence buildings are constructed of U-shaped precast concrete panels, which are cantilevered out to form overhangs on the east and west sides of each building. Both buildings have cast-in-place concrete foundations. Throughout the complex, particular care is given to the detailing and finish of exposed concrete elements. Roof structures project on the residence wings, precast panels are exposed as finished ceilings, and the contrast of smooth and exposed aggregate finishes is carefully considered. The expression and exposure of structural elements is an important tenet of modernist architecture and is a character-defining element of the Lutheran Seminary.

2.6 Uses

Theological education, study, worship, and residential accommodation are the defining functions of a seminary and are therefore the principal character-defining uses of the Lutheran Theological Seminary. These functions are supported by classrooms, seminar rooms, a library, and a chapel, all of which have retained their original uses. A ground floor dining room and kitchen have in recent years fallen into disuse. Ancillary functions include a book store and general office area. The Student Residence and Deans Residence maintain their commemorative integrity as living quarters. Some changes have occurred; the Dean's Residence no longer houses the Dean, but accommodates several students. Many of the ground floor rooms of the Student Residence were converted into offices when the College of Emmanuel and St. Chad moved its operations to the Lutheran Seminary in 2005. This change in use has not caused any alteration in the spatial configuration of the rooms.

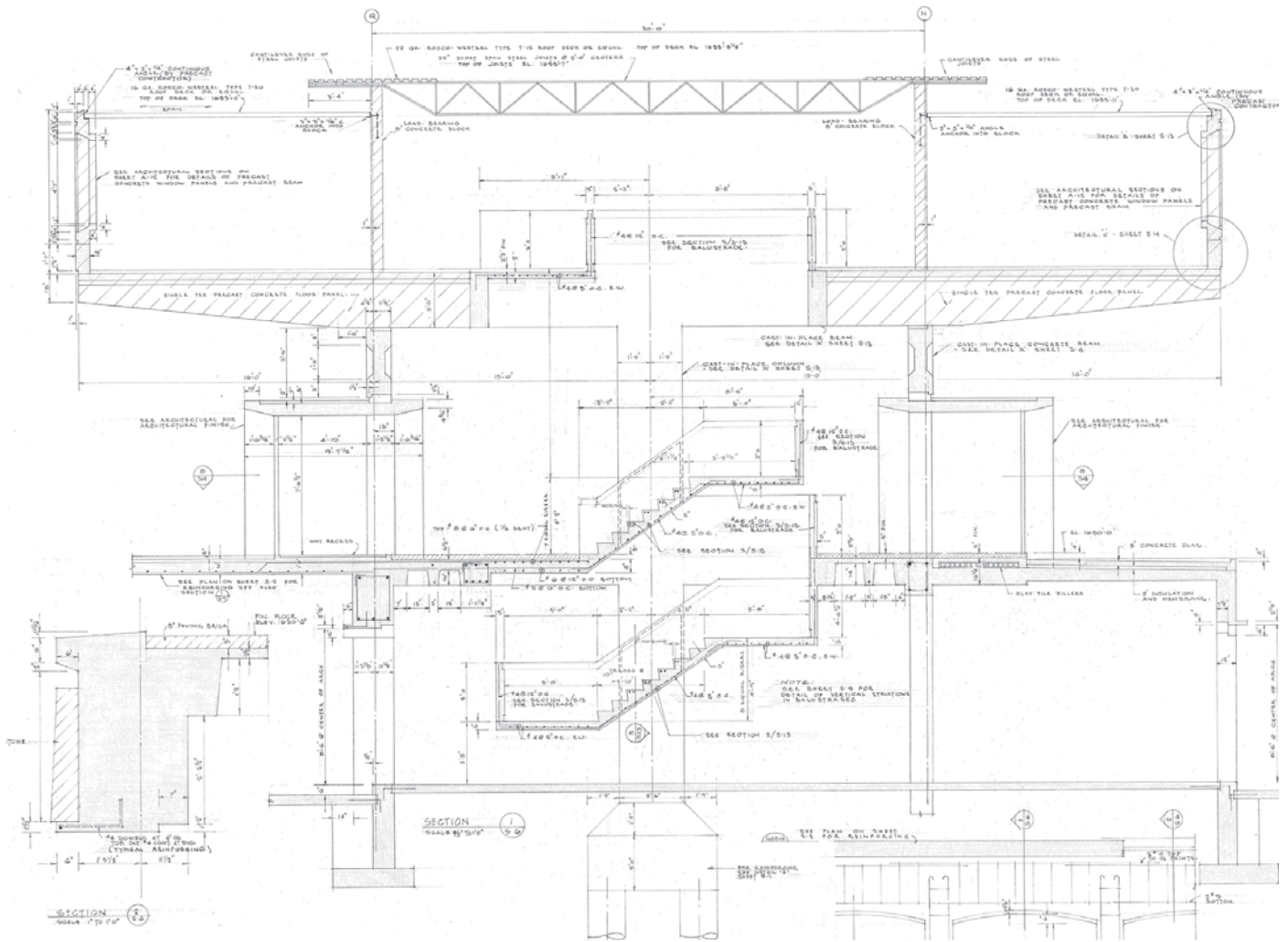

Originally, the student dormitories were used solely by men. In 1970, in response to declining enrollment, the board voted in favour of mixed dormitories (Hordern, 1994). Tower One accommodated men and Tower Two women. Tower Two has also been used recently to house researchers visiting the nearby Canadian Light Source (CLS). Currently, Tower Two houses students attending Emmanuel and St. Chad College.

Figure 35. A section through the Academic College Building. Retrieved from Facilities Management Division Asset Record System, File 938-119-T.

2.7 Cultural & Chronological Associations

The Lutheran Seminary buildings can be associated with the merger of the Lutheran Theological Seminary and the Lutheran College and Seminary. The merger of the two schools occurred in 1965, and this provided impetus for the construction of the seminary complex.

The Seminary's first female student, Margaret Tsan spent one year in the Seminary before graduating in 1969, making her the first woman to attend the Lutheran Seminary or its predecessors. The ordination of women did not come into regular practice until 1976, when the Evangelical Lutheran Church of Canada voted in its favour.



Figure 36. The chapel in use as a place of worship. Retrieved from http://www.usask.ca/stu/luther/images/chapel_header.jpg

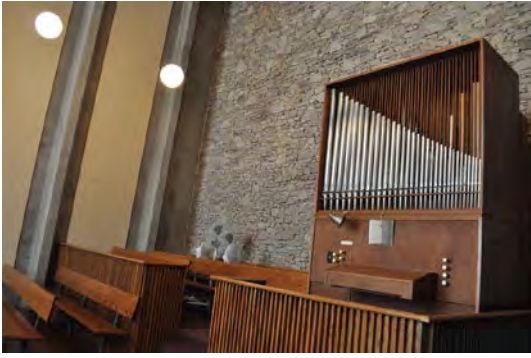

Figure 37. The organ situated in the choir at the rear of the Chapel.

The Lutheran Seminary buildings can be associated with their architect, John Holliday-Scott. Working with his firm Holliday-Scott Paine, he was also responsible for the design of the [Dental Clinic](#) and the [Law-Commerce Complex](#) at the University of Saskatchewan. Holliday Scott was born in the UK, and immigrated to Canada in 1957 after receiving his architecture degree from Kingston College of Art. In Canada, Holliday Scott first worked with the Saskatoon Firm Kerr and Cullingworth for two years before starting his own firm. Holliday Scott is a lifetime member of the Saskatchewan Association of Architects.

3. Associated Objects

The altar and lectern at the head of the chapel match the choir in their style and materiality. The library desk and chapel pews are also part of the original oak furnishings.

The organ in the chapel was purchased at the time of the building's construction for \$12,000 (Figure 37).

4. Supporting Documents

Facilities Management Division (2011). Asset Resource Database [Data File]. Retrieved from \\usask\fmddfs\files\iis\IIS_Public\ARS

Hordern, W. (1994). *Challenged by Change: Memoirs of a Seminary President*. Occasional Publications: Regina.

Lutheran Seminary Archives. *Position Paper on Master Plan*. University of Saskatchewan Archives. (Retrieved 2013). Campus Buildings: Lutheran Theological Seminary. Retrieved from <http://scaa.usask.ca/gallery/uofs/buildings/>

5. Summary of Character - Defining Elements

Materials

- precast concrete wall panels, in smooth and exposed-aggregate finishes
- precast concrete floor panels
- greystone walls
- painted concrete and concrete block
- oak doors, wall panels, baseboards, balustrades, window and door frames
- stainless steel fixtures
- painted steel balustrades and staircases
- terra cotta floor tile
- aluminum and steel framed

glazing

- painted blue details

Form & Style

- intersection of volumes and materials
- structural expression of concrete elements
- exposed beam ends on chapel
- canted walls, windows and concrete detailing
- bridge entrance
- arched windows and doors
- cantilevered concrete roof projections

Location

- University of Saskatchewan
- riverbank site





Spatial Configuration

- cloister arrangement
- canted chapel walls
- double-height reading room in the library
- clerestory windows in Dean's Residence and Student Residence
- separation of Tower One and Tower Two in the Student Residence
- residence rooms clustered around lounges

Systems

- exposed concrete structure

Uses

- worship
- theological studies and ordination
- residential accommodation

Cultural & Chronological Associations

- Lutheran Church Merger resulting in creation of Lutheran Theological Seminary Saskatoon
- ordination of women
- Architect John Holliday-Scott

Devil's Dip



Devil's Dip

Alternate Names

N/A

Architect(s)

N/A

Builders

N/A

Construction Dates

N/A

Recognition

N/A

1. Statement of Significance

Devil's Dip is a ravine on the south-east bank of the South Saskatchewan River, on the grounds of the University of Saskatchewan. Its primary significance to the history of the university relates to the original 1909 Campus Plan by the Architects David Brown and Hugh Vallance. This plan was designed such that its primary axis, laid out perpendicular to the river, aligned with and terminated at Devil's Dip. [‘The Bowl’](#), which developed into the focus of the U of S campus, and all of the buildings around it, are laid out according to this axis, which is oriented 28.5 degrees south of due east. The 1909 plan governed the development of the campus until the late 1950's, when a deliberate shift away from its formal Beaux Arts principles took place. The construction of the campus began with the [MacKinnon Building](#) in 1910, some distance away, and was intended to advance towards the river over time. However, because the plan was abandoned before development took place near the river, the formal relationship between the campus plan and Devil's Dip is not apparent to an observer on the ground.

Devil's Dip also has heritage value with respect to the university community as it was part of the frosh week campus tradition for many years. The ravine can also be associated with the Saskatoon Ski Club who built their first jump and held their first championship there.



Figure 1. Native grasses and tree species.



Figure 2. A Tatarian Honeysuckle, not native to Saskatchewan; part of the diversity found on the riverbank.

2. Character - Defining Elements

2.1 Materials

The plant materials of Devil's Dip are predominantly naturally occurring species native to Saskatchewan. They include wild grasses, flowers and trees as shown in Figure 1. The trees present are mostly deciduous and low-lying, and many produce berries as shown in Figure 2. A 1928 photograph, Figure 3, shows the state of growth in the ravine at that time. The Meewasin Valley Trail, a foot and bicycle path developed during the 1980's, skirts Devil's Dip to the south and north. The plants of Devil's Dip, including its native grasses, trees and flowers are its principal material character-defining elements.

2.2 Location & Form

Devil's Dip is located on the east bank of the South Saskatchewan River, between the 25th street (University) Bridge and the Diefenbaker Building on the grounds of the University of Saskatchewan (Fig. 6). The property also falls within the 'conservation zone' of the Meewasin Valley Authority.

Devil's Dip is a natural ravine, the formation of which began in the Pleistocene period, when Saskatchewan was covered by a succession of glaciers. The last and largest of the glaciers to enter the area is known as the Wisconsin Glacier. It carried soil and rock from the Canadian Shield and deposited this material on the plains as it melted and receded north. The melt water formed a lake that remained in the vicinity for 3000 years. The eventual drainage of Lake Saskatoon took the form of a broad flow channel that settled to become the South Saskatchewan River. The river valley, formed by erosion and the shifting position of the river over time, is a land form highly differentiated from the surrounding prairie. Devil's Dip forms part of the river valley.

As a land form, Devil's Dip has been preserved to a high degree of commemorative integrity, although this integrity is threatened. The east bank of the South Saskatchewan River is unstable and actively slumping. Because of its location on the east bank, Devil's Dip is threatened by the same forces that have caused instability on other sections of the riverbank in Saskatoon. Figure 5 shows the form of the ravine in the 1940's.

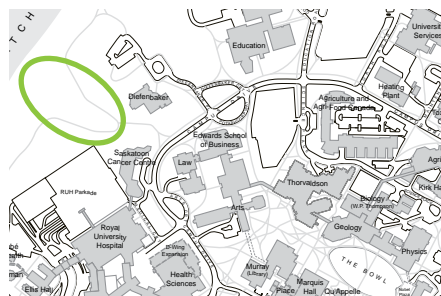

Figure 6. Devil's Dip circled in green on this contemporary campus plan.



Figure 3. The University in 1928. Devil's Dip at the far left. Photo A-184 retrieved from University of Saskatchewan Archives.



Figure 4. Devil's Dip in winter. Exact date unknown; the Bessborough, visible in the background, was constructed in 1931. Photo PH 91-177-77 retrieved from http://spldatabase.saskatoonlibrary.ca/internet/LHR_RADQuery.htm



Figure 5. Devil's Dip, possibly in the 1940's. The Bessborough, visible in the background, was built in 1931. Photo PH 91-177-73 retrieved from http://spldatabase.saskatoonlibrary.ca/internet/LHR_RADQuery.htm



Figure 7. A portion of the 1909 Campus Plan by Brown and Vallance. Devil's Dip is circled in green. North is oriented to the left.

Devil's Dip is also of significance due to the important role it played in the formal layout of the University of Saskatchewan. The first university architects, David Brown and Hugh Vallance, aligned the primary axis of the 1909 Campus Plan with Devil's Dip. The axis, oriented 28.5 degrees south of due east, is apparent when the campus is viewed in plan (Figure 7). From Devil's Dip, a grand boulevard would radiate towards a central courtyard (now ['The Bowl'](#)), around which academic buildings would be placed. The buildings shown in the 1909 plan indicate a constructed

landscape along the riverbank. Buildings and terraces along the top of the riverbank would overlook the landscape of the ravine and the river. A bridge is visible spanning Devil's Dip. The axis of Devil's Dip was respected in campus planning until the late 1950's. Much of the spatial configuration and form of the current university is based on its alignment with this natural feature.

2.3 Use(s)

Devil's Dip has seen numerous uses associating it with student life and tradition at the University of Saskatchewan. The earliest recorded recreational use of the ravine was as a ski jump. In January 1929, President Walter Murray gave permission to the newly formed Saskatoon Ski Club to build a ski slide on 'the big hill near the Varsity.' In the winter of 1929 – 1930 a wooden ski jump on the banks of the Saskatchewan River was built at Devil's Dip earning it the name 'Devil's Dip Ski Jump.' The jump only lasted one season. Figure 8 may be a photograph of the ski jump at Devil's Dip.

The Devil's Dip ski jump had a K point or critical point of 80 meters, indicating that the target jumping distance was 80 meters from the jump and that is where most skiers would land. The first club championship of the Saskatoon Ski Club was held there in 1930. A skier broke his leg during the competition, and the ski jump was closed. Later, a second jump was built north of Devil's Dip, at a site now called 'Ski Jump Coulee.'

At one time it was a popular feat to try to climb the riverbank at Devil's Dip on motorcycle. Crews with ropes and hooks would accompany the riders to save the bikes if the rider lost control.



Figure 9. Leisure activities at Devil's Dip.

By the 1940's Devil's Dip had become part of the tradition of frosh week. First-year students would assemble at a campfire to learn Varsity songs and yells, meet campus dignitaries and sing songs. Devil's Dip became the favoured location for these events, at which university dance bands would provide music. The campfire tradition of frosh week was recorded as early as 1941 and bands provided music to the campfire gatherings from

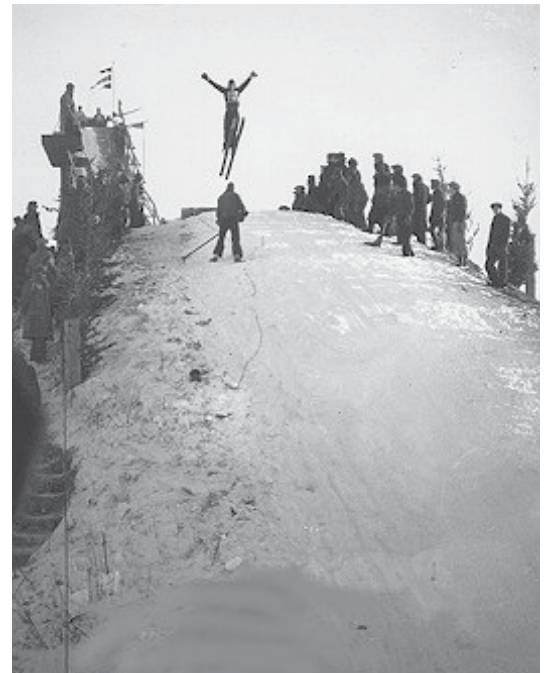

Figure 8. The ski jump in this photograph, may be the one that existed at Devil's Dip. Devil's Dip Ski Jump was the first on the banks of the Saskatchewan River and was constructed in 1929. This photograph is dated 1925, but that date may be in error. Retrieved from <http://www.skisprungschanzen.com/EN/Ski+Jumps/CAN-Canada/SK-Saskatchewan/Saskatoon/0117/>



Figure 11. Plaque honouring Glen Makahonuk.



Figure 12. Tamara's House River Stewardship Program plaque.

1945 to 1965. The gatherings at Devil's Dip were later called dance parties.

In 1979, the Meewasin Valley Authority (MVA) was created – an autonomous planning and conservation agency charged with the protection and development of the South Saskatchewan River Valley. The University of Saskatchewan was a partner in the creation of this organization, along with the City of Saskatoon, the Province of Saskatchewan and the R.M. of Corman Park. (Meewasin Valley Authority, 2005). The goals of the MVA were developed and guided by the 'Meewasin Valley Project', a 100 year conceptual master plan by Raymond Moriyama Architects and Planners. The immediate river valley lands, including Devil's Dip, are reserved for natural habitat conservation and as a public amenity. The Meewasin Valley Trail, a system of pedestrian and cycling paths, was subsequently developed along both banks of the river, including across Devil's Dip. (Figure 9 shows one of the trails).

3. Associated Objects

Two plaques are located in Devil's Dip. One commemorates the life of the late Glen Makahonuk who died in 1997 serving as the President of the CUPE 1975 union. The other plaque is in honor of 'Tamara's House,' and reads 'river stewardship program Meewasin.' Figures 11 and 12 show these plaques.

4. Supporting Documents

Author Unknown. (October 19, 2007). Tour Explores Creepy Part of Campus. *On Campus News*, . Retrieved from http://news.usask.ca/archived_ocn/07-oct-19/14.php

Author Unknown. (October 2, 1998). Makahonuk Memorial Located on Campus. *On Campus News*, 6(3). Retrieved from http://news.usask.ca/archived_ocn/Oct2-98news5.html

Eyre, W. (September 5, 1997). From the University Archives: A Brief History of Frosh Week. *On Campus News*,. Retrieved from http://news.usask.ca/archived_ocnSept5/archives.html

Hayden, M. (1983). *Seeking a Balance: University of Saskatchewan, 1907-1982*. Vancouver: University of British Columbia Press.

Hayes, P. (January 23, 2009). From the Archives: The Big Jump. *On Campus News*, . Retrieved from http://news.usask.ca/archived_ocn/09-jan-23/fromthearchives.php.

Meewasin Valley Authority. (2005). *About Meewasin History*. Retrieved from <http://www.meewasin.com/about/>

Raymond Moriyama Architects and Planners. (1978). *The Meewasin Valley Project*. Saskatoon: Raymond Moriyama.

Saskatoon Public Library. (Retrieved 2012). *Popular Searches of the Local History Room Collections Database*. Retrieved from http://spldatabase.saskatoonlibrary.ca/CSDATA/LH_Canned_Searches/canned_searches

Ski Jumping Hill Archive. (Retrieved 2012). *Saskatoon*. Retrieved from <http://www.skisprungschanzen.com/EN/Ski+Jumps/CAN-Canada/SK-Saskatchewan/Saskatoon/0117/>

Walking Tour. (Retrieved 2012). *G.W. Norman Printer 225 20th Street West*. Retrieved from <http://www.riversdale.ca/walkingtours.php?page=gw-norman>

Weins, L. (Fall 2001). A Great Choice: Molloy Selected as New Chancellor. *Green and White*. Retrieved from <http://www.usask.ca/greenandwhite/issues/2001/fall2001/features/1003956556.php.history/>



5. Summary of Character - Defining Elements

Materials:

- native grasses
- deciduous trees and bushes
- wild flowers

Form:

- result of glaciofluvial processes
- naturally occurring ravine

Location:

- South Saskatchewan River, east bank
- University of Saskatchewan

Spatial Configuration:

- natural ravine formation
- views

Uses:

- ski jump
- frosh week campfires
- natural habitat conservation
- public river access and leisure

Cultural and Chronological Associations:

- University of Saskatchewan
- Brown and Vallance 1909 Campus Plan



Ernest Lindner Studio



Ernest Lindner Studio

Alternate Names

Lindner Cabin

Designer

Unknown

Builders

Unknown

Construction Dates

1935

Recognition

Provincial Heritage Property, Designated 2007

University of Saskatchewan 'B' Listed

1. Statement of Significance

Ernest Lindner was a nationally recognized artist, known particularly for his engravings and watercolours. His works have shown throughout Canada and internationally at Canada House Gallery, in London, England, and at Canadian Cultural centres in Paris and Brussels. Lindner was a member of the Order of Canada, received an Honourary Doctor of Law Degree from the University of Saskatchewan in 1972, and a Life Time Award for Excellence in the Arts from the Saskatchewan Arts Board in 1988. Lindner passed away in Saskatoon in 1988.

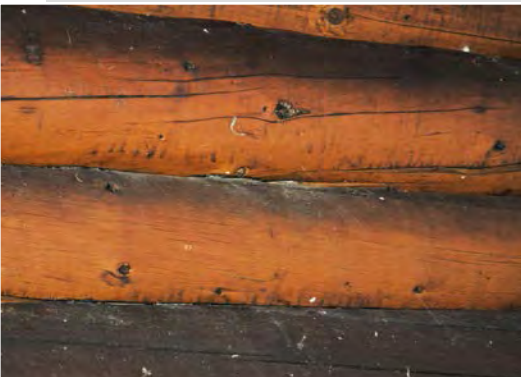

Figure 1. Logs showing gaps in need of re-chinking.



Figure 2. A 2007 photograph of the front of Linder's Studio. Retrieved from <http://www.historicplaces.ca/en/rep-reg/image-image.aspx?id=10429#i1>

Lindner moved to Canada from Austria in 1926. Ten years later, he established a summer home and art studio on an island at Emma Lake. Lindner and his wife named this place 'Fairy Island'. Later, the peninsula on which his studio stood would become known as Lindner Point. At his summer studio Lindner produced many works; it was the setting of Fairy Island that inspired much of his watercolor work. Lindner received artistic instruction from university artist-in-residence Augustus Kenderdine. Lindner was also instrumental in influencing University of Saskatchewan President Walter Murray and Kenderdine to open an art camp at Emma Lake, across the water from his studio. In 1961, Lindner sold his studio to the university. In 1962, Fairy Island was declared a game preserve and in 2007 Lindner's studio became a Provincial Heritage Property owing to its association with Lindner and the works he produced there.

*Note: The Studio consists of a partial basement and a ground floor. A second floor was added later. The floors are referred to in this document as basement, ground floor and second floor.



Figure 3. Lindner's studio window with painted shutters nailed shut.



Figure 5. Spruce logs, fir trim and brass hardware.



Figure 6. Wooden trussed rafters.



Figure 7. State of roofing material.



Figure 4. "The Cabin (with Bodil and Degen)." Retrieved from <http://www.hodginsauction.com/hodgins/>.

2. Character - Defining Elements

2.1 Materials

Lindner's Studio is a log cabin, made primarily of spruce logs harvested from the island. The logs are supported by a combination of concrete foundations, spruce logs and stones. On the interior of the cabin, the spruce logs are finished with linseed oil (Figure 1), and on the exterior they have been painted (Figures 2 & 3). The windows and shutters are also made of wood. The spruce logs that form the walls of the cabin have retained good commemorative integrity. The interior of the cabin has maintained its oiled finish beautifully. However, the spruce log walls are in need of re-thinking. Figure 1 illustrates one of the many spots where gaps in the log walls might allow air and water to penetrate.

The wooden window frames and shutters have also been painted on the exterior (Figure 3). Some original shutters have been retained and some new counterparts have been added. In recent years, the building has experienced repeated acts of vandalism, including having all of its windows broken more than once. To protect the building from further damage the windows have had their shutters nailed closed. This necessary provision, while protecting the cabin from further degradation of its heritage value, represents a loss to its commemorative integrity and a change in its character. Figure 3 shows one of Lindner's corner studio windows with its shutters painted and nailed shut. Lindner's portrayals of the cabin in his artwork suggest that the trim of the building has always been painted (Figure 4). Figure 5



Figure 8. Damage due to vandalism.

shows the wooden window frames without paint on the interior.

The ceiling of the studio is characterized by exposed wooden construction. The visibility of the wooden rafters is a character-defining element of the cabin. The materiality of the rafters is shown in Figure 6. (See Section 2.6 Systems).

Figure 7 shows that the roof of the studio is in disrepair. The shingles are severely deteriorated. On the interior, the roof decking shows signs of water damage in places. The wood of the roof is still in excellent condition; however, the condition of the shingles is a threat to its commemorative integrity.

Lindner's daughter maintains that the roof was not finished originally in cedar shakes, as has been speculated, but in asphalt shingles.

When the university took possession of the cabin, a second floor was built using fir. Although not original, this material has been well maintained. Other renovations included the erection of interior partition walls of painted plywood or waferboard. These walls and doors show signs of vandalism. Some of the original materials of the building have fallen victim to vandals (Figure 8), threatening their commemorative integrity.

2.2 Form

The form of the cabin is character-defining in its simplicity and scale. The cabin is rectangular, 1.5 storeys high, with a pitched roof (Figure 9). The simplicity of the design, its pitched roof and log walls are important character-defining elements classifying the studio as a cabin.



Figure 9. A 2007 photograph of the rear of Linder's Studio. Retrieved from <http://www.historicplaces.ca/en/rep-reg/image-image.aspx?id=10429#i1>



Figure 10. Saddlenotched logs.

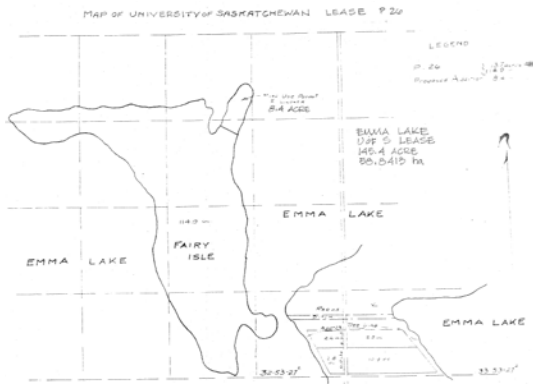

Figure 11. The location of Lindner Point on Fairy Isle. Retrieved from Facilities Management Division Asset Record System, File E-108-T.

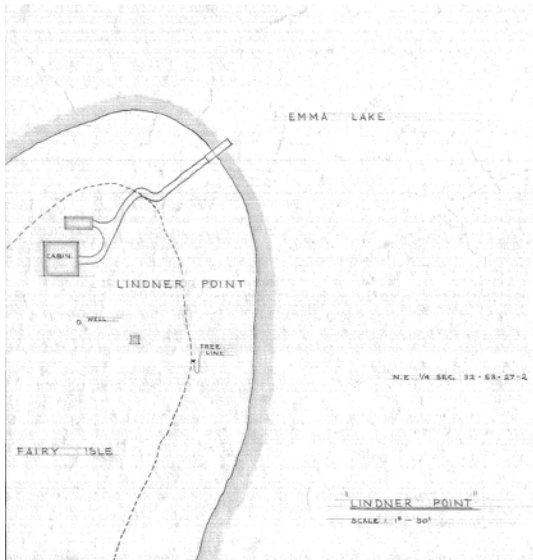

Figure 12. The location of Lindner's Studio and summer kitchen on Lindner's Point in 1964. Retrieved from Facilities Management Division Asset Record System, File E-70-T.

2.3 Style

The building is in no particular architectural style, but is a fairly typical example of a small log cabin. Its spruce log construction, and the visibility of the logs on the exterior and interior of the cabin are both character-defining elements. The exterior corners, where the logs overlap, are also character-defining elements, the integrity of which have been maintained (Figure 10). The pitched roof and exposed wooden roof decking and rafters are character-defining elements that have all been well maintained. The original double height one room style of the cabin has been compromised by the addition of a second floor. (See Section 2.5 Spatial Configuration).

2.4 Location

Accessible only by water, the Ernest Lindner Studio is located on a peninsula projecting from Fairy Island, now known as Lindner Point. The location of Lindner Point is shown in Figure 11. The location is significant as it was Lindner and his wife Bodil who settled the island and gave it its name. The Lindner's also left their mark on the island in various ways. Ernest created a path that encircled the entire island and framed it in poplars. The ground outside the cabin still shows evidence of the cold storage pits they dug there. There is record of Lindner having built a bridge on the island. Figure 12 shows the location of the cabin on Lindner Point. Lindner's painting, "The Cabin (with Bodil and Degen)," 1936, offers some insight as to how the site may have originally appeared and is shown in Figure 4.

This location also inspired many of Lindner's works (Figure 4). The location of the studio on Lindner's Point on Fairy Island, in an undeveloped forest setting is a character-defining element of the property.

The island was attractive to the University of Saskatchewan as a venue for painting. In 1961, the university bought the two buildings on Lindner's Point and took over the lease of the property. In 1962 the University of Saskatchewan had Fairy Island declared a game preserve, where no hunting or trapping could occur. This applied to the entire area except for 66 feet of the foreshore.



Figure 13. "The Cabin" by Ernest Lindner. Retrieved from <http://www.gallery.ca/en/see/collections/artwork.php?mkey=41918>

2.5 Spatial Configuration

Originally, the cabin consisted of one floor with a basement. The ground floor was entirely open, as shown in Figure 14. When the cabin was acquired by the university, it was partitioned and a second floor was added. The ground floor was divided into four rooms and the new second floor was built with two rooms. The original layout of the cabins has therefore been compromised. The open plan and double height vaulted ceiling were character-defining elements. The same can be said for the windows; without glazing the character of the interior space has been substantially changed. Figure 14 shows that originally the cabin featured skylights and a floorlight. These character-defining elements are now gone.

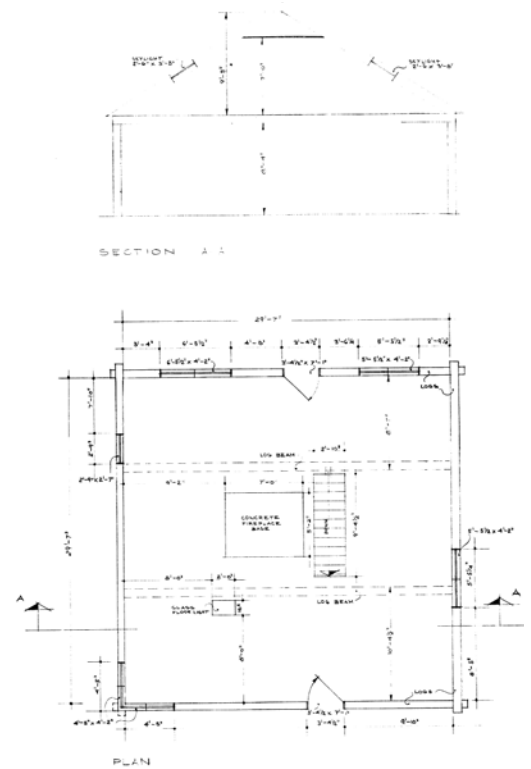

Figure 14. The layout of Lindner's Studio in 1961. Retrieved from Facilities Management Division Asset Record System, File E-49-T.



Figure 15. L to R: coal chute and a rock supporting the cabin's base.

2.6 Systems

The primary structural system of the cabin consists of its log walls, with saddle-notched corners. The foundations of the Lindner cabin are a combination of concrete, stones, and logs. A concrete strip foundation supports the walls on the east and west sides. On the north and south, rocks and logs can be seen supporting the cabin walls. This ad hoc system of support is a product of the undeveloped nature of the site; the cabin was built from what was available on the island. Figure 15 shows a rock supporting the cabin.

Another system characteristic of the time of the cabin's construction is the coal chute. The wooden chute (Figure 15) still exists on the north side of the cabin. The chute is a character-defining element of the building, although the use of coal heat is not.

2.7 Use(s)

The cottage was built as a summer residence and studio for Ernest Lindner, his wife Bodil and their daughter, Degen. The family moved onto the island in 1935. Ernest Lindner produced many of his artistic works here. The building served as a cabin and studio until 1961, when Lindner sold the studio to the University of Saskatchewan.

After its acquisition by the university, the cabin was used for instruction in art and biology. Scrapbooks by the students of the Emma Lake Art School record field trips to the island for painting. 1965 saw Lindner's Studio used by the Biology department as a provincial research area for biologists, botanists, zoologists, limnologists and other environmentalists.

In 2012, the Kenderdine Campus of the University of Saskatchewan was closed due to budgetary constraints. At the time of this report, the Ernest Lindner Studio is not being used or occupied. The derelict state of the cabin represents a threat to the heritage value of the site. With no occupants, the seclusion of the property exposes it to vandalism and deterioration.

2.8 Cultural & Chronological Associations

The Lindner Cabin is associated with the nationally renowned artist Ernest Lindner who lived and painted there. Figure 16 shows a corner window where he liked to sit and paint. Many of Lindner's works can also be associated with the cabin (Figures 4 & 13).

The studio is also associated with the Kenderdine Campus located across the lake from the building. Lindner was involved in the campus during the 1950's and 1960's. He took art lessons from well known local artist Augustus Kenderdine. Lindner was also instrumental in getting Kenderdine and University President Walter Murray interested in establishing the site as a remote campus of the university.

3. Associated Objects

The white stove in the Lindner cabin is original to the building (Figure 17). Unfortunately, this piece of memorabilia has been vandalized; the stove pipe has been disconnected and the finish of the stove has been marred by pellet gun shots.



Figure 18. Commemorative plaque.

A small brass plaque set into a low stone monument commemorates the Lindner Cabin as a Provincial Heritage Property (Figure 18). The stones forming the monument originally formed part of the outdoor hearth that the Lindner family used. The monument is also placed in the approximate original location of the hearth.



Figure 16. Lindner's corner studio window. Retrieved from www.historicplaces.ca



Figure 17. Original wood-burning stove.

4. Supporting Documents

ArtSask 2012. (Retrieved 2012). *Ernest Lindner*. Retrieved from <http://www.artsask.ca/en/artists/ernestlindner>

Author Unknown. (October 5, 2007). Studio Declared Heritage Site. *On Campus News*. Retrieved from http://news.usask.ca/archived_ocn/07-oct-05/12.php

Avery, C. (1999). Incentive to Vision: The Emma Lake Art Camp. *Art Libraries Journal* 24(3), 19-24.

Beamish, M. (after 1947). *How Murray Point Art Camp Began*. Retrieved from <http://scaa.usask.ca/gallery/murray/search/index.php?ID=54444&field=keywords&search=emma&page=2&part=5>

Facilities Management Division (2011). Asset Resource Database [Data File]. Retrieved from \\usask\fmddfs\files\iis\IIS_Public\ARS

Hayden, M. (1983). *Seeking a Balance: University of Saskatchewan, 1907-1982*. Vancouver: University of British Columbia Press.

Parks Canada. (Retrieved 2012). *Ernest Lindner Studio on Fairy Island*. Retrieved from <http://www.historicplaces.ca/en/rep-reg/place-lieu.aspx?id=10429>

Paul Trottier, personal communication, May 29, 2012.

University of Saskatchewan Archives, Controller's Office Fonds, 9, Series I. Vice President - Administration. II. Buliding Files, 15. Emma Lake Art Campus, 1949-66.

University of Saskatchewan Archives, Publications 52., Arts and Science (College), 3, Art 2. Bulletins and Research Reports.

University of Saskatchewan Archives, Publications 52., Arts and Science (College), 3, Art 1. Calendars and Timetables.

University of Saskatchewan Archives, Publications 52., Arts and Science (College), 3, Art 12. Histories.

University of Saskatchewan Archives, MG183 Mac and Beth Hone Fonds, 7, 1.2 Personal Correspondence Ernest Lindner VP of Canadian Arts council.



5. Summary of Character - Defining Elements

Materials	<ul style="list-style-type: none">▪ spruce log walls▪ wooden structure▪ wood-framed windows▪ linseed oil finish
Form	<ul style="list-style-type: none">▪ pitched roof▪ rectangular plan
Style	<ul style="list-style-type: none">▪ log cabin
Location	<ul style="list-style-type: none">▪ Fairy Island▪ Lindner Point▪ natural surroundings
Spatial Configuration	<ul style="list-style-type: none">▪ double-height space▪ vaulted ceiling▪ open floor plan
Systems	<ul style="list-style-type: none">▪ saddle-notched, stacked logs▪ lapped floor decking▪ exposed rafters
Uses	<ul style="list-style-type: none">▪ residence▪ art studio▪ education in art and
biology Cultural & Chronological Associations	<ul style="list-style-type: none">▪ Ernest Lindner▪ Kenderdine Campus▪ Fairy Island



'Gus' Kenderdine Studio



'Gus' Kenderdine Studio

Alternate Names

Kenderdine 9
Kenderdine Bunk Cabin
Kenderdine Cottage

Architect

Fred Cowley

Builders

Fred Cowley

Construction Dates

1936

Recognition

University of Saskatchewan 'B' Listed



Figure 1. Exterior log siding.



Figure 2. Exterior log siding and painted wood trim.

1. Statement of Significance

The Kenderdine Studio derives much of its heritage value from its association with Augustus Kenderdine. Kenderdine was a nationally-renowned landscape and portrait artist, best known for his work in Saskatchewan between 1920 and 1947. Kenderdine was appointed to the position of 'artist-in-residence' at the University of Saskatchewan in 1923. He was responsible for establishing the Murray Point Art School at Emma Lake in 1936. The Art School was later renamed the Kenderdine Campus in his honour.

Kenderdine and his friend Fred Cowley built Kenderdine's small studio on Murray Point in 1936, as accommodation while he lectured on art at the Emma Lake Art School. Many of Kenderdine's paintings were created in the cabin. The construction of Kenderdine's Studio marks the beginning of the University of Saskatchewan's relationship with Emma Lake and the creation of this internationally renowned art school.

2. Character - Defining Elements

2.1 Materials

Gus Kenderdine's studio at Emma Lake is built of spruce lumber procured from sawmills local to the site at Emma Lake. The lumber is in the form of both cut wood and log siding (Figures 1 & 2). The cut wood has been painted, but the log siding remains unfinished, with the exception of the upright logs on either side of the door. A 1936 photo shows the cabin with painted wood trim and unfinished log siding, so the exterior appears to have retained its commemorative integrity. A materials order quotes paint for the cabin as being 'extra optional.' The original porch decking has been replaced by plywood. The roofing is currently asphalt, however, it was originally specified to be 'native shingles,' presumably spruce.



Figure 3. A 1936 photo of Kenderdine's Studio. Photo by E.N. Davis. Retrieved from Kenderdine Campus Dining Hall.



Figure 4. Interior bedroom materials.



Figure 5. Flooring materials.



Figure 6. Bedroom window with sliding wooden shutter.



Figure 7. The form of the studio.

The interior of the cabin consists of painted cedar tongue & groove boards, visible in a 1936 photo (Figure 3). This finish material largely remains in place, except for the addition of several sheets of painted particle board, shown in Figure 4. The flooring in the cabin was originally spruce, which remains in existence. In the bedroom it is exposed, but painted, and in the larger room it is covered by a layer of linoleum (Figure 5).

The windows have lost some commemorative integrity. The glass in the north window in the large room has been replaced with a sheet of clear plastic. The southern window appears to have been maintained, as has the bedroom window. The bedroom window is shown in Figure 6. A painted interior wooden shutter can still slide over this window. Both original windows are wood-framed with single-paned glazing. The other two windows have wooden brackets for sliding shutters, but the shutters are missing. A modern aluminum-framed window has been installed in the original wooden door. A built-in pantry is also constructed of wood. Records show that the curtains in the cabin have been replaced and the current ones are not original.

2.2 Form & Style

The cabin is very small, measuring approximately six feet by 15 feet and is one reduced storey in height. This diminutive scale is a character-defining element. The rectangular shape and pitched roof of the cabin are also character-defining elements (Figure 7).



Figure 8. Pitched roof and antlers.

The rustic style of the summer residence and studio is primarily a function of its materials. The spruce log siding on the exterior is a character-defining stylistic element (see Section 2.1 Materials).



2.3 Location

The site for the Emma Lake Art Camp and the Kenderdine studio was chosen by Gus Kenderdine on a canoe trip with his family. The principal reason for selecting the site was that it contained a stand of maturing trees with a predominance of slower-growing, long-lived varieties. The undisturbed natural environment of the area is thus a character-defining element of the location.

The site, on a peninsula extending into Emma Lake, was known as 'The Point' before Mrs. Kenderdine came up with the name 'Murray Point.' In 1935, under the auspices of the university, Kenderdine leased 11 acres on Murray Point to start the art camp. The location of the Kenderdine cabin is of heritage value in that it was both chosen and named by the Kenderdine family. In 1966 the university purchased more land at Emma Lake to protect the integrity of the camp from the encroachment of development happening nearby. The site officially changed its name from the 'Emma Lake Art School' to 'Kenderdine Campus' on July 23, 1989. The location of the cabin at Murray Point is shown in Figure 9.

Figure 9. The location of Kenderdine Studio is indicated in green on an early map of Murray Point. Many of the buildings shown have been demolished and replaced at other locations. Map Retrieved from Kenderdine Campus Dining Hall.

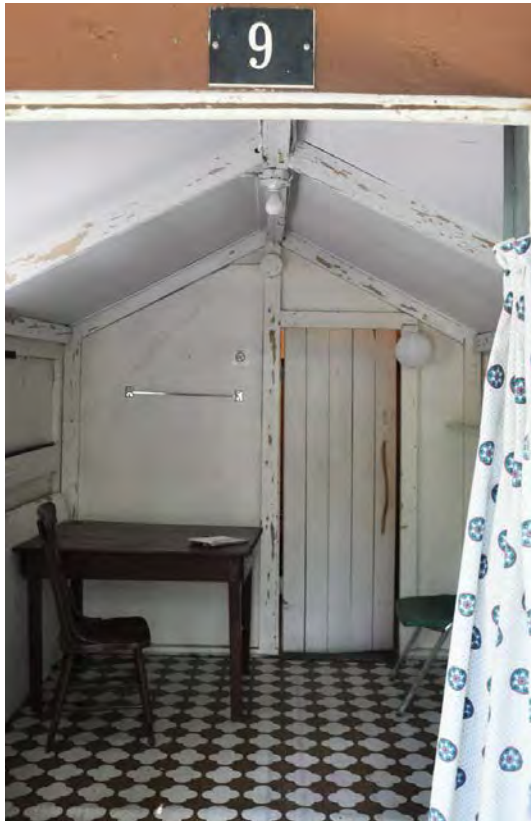

Figure 10. View into the cabin from the doorway.



Figure 11. A wooden pantry built into the northeast corner of the cabin.

2.4 Spatial Configuration

The Kenderdine Studio has retained the commemorative integrity of its original layout. The cottage still consists of two rooms: a larger room containing stove and pantry, and a smaller bedroom. The two room configuration shown in Figure 10 is a character-defining element. Figure 11 shows the only built-in fixture of the cabin: a wooden pantry.

2.5 Systems

The base of the cabin is supported by two logs that lay directly on the ground beneath the floor. This ad-hoc foundation is a character-defining element.

A wood-burning stove, still in existence, provided heat (Figure 12). The stove appears to have been moved. Photographs show a stove pipe in the north-west corner of the large studio space. It is now installed in the south-east corner. The original stove pipe was replaced in 1953.



Figure 12. Original cookstove.

In 1960, electrical service was installed at the Emma Lake Art Camp and has been retrofitted to the cabin. The electrical fittings in the cabin are not character-defining elements.

2.6 Use(s)

The cottage was originally used as a summer residence and studio by Augustus Kenderdine. It was built to accommodate Kenderdine as he served as a lecturer and director at the Emma Lake Art School. The bunkhouse cabin served as a studio for the decade that Kenderdine spent at the camp. Figure 3 shows an easel inside the cabin. At some point in Kenderdine's tenure as director, he built a larger cabin to accommodate his family. After Kenderdine's death in 1947, his cabin served as a student residence.

In 1964 it was suggested at a meeting of the university Board of Governors that the Kenderdine Studio serve as a museum. It was recognized that the building would rapidly deteriorate if it was not restored. In 1965 a proposal to preserve the Kenderdine cottage was put forth.

2.7 Cultural & Chronological Associations

The studio and cottage is associated with its first resident artist, Augustus Kenderdine. Kenderdine was a renowned Saskatchewan portrait and landscape painter in the romantic tradition. He was born in Lancashire, England. He first studied art under his godfather, Chevalier de la Fosse, a Belgian-born painter and photographer, at the Manchester School of Art. He later also briefly studied and exhibited in Paris. Upon returning to England, he became well established as a painter, exhibiting locally and in London. However, in 1908 he immigrated to Saskatchewan, homesteading near Lashburn. After 10 years of farming, he returned to painting.

In 1920, Kenderdine met Walter Murray, the President of the University of Saskatchewan, who wanted to establish an art program. Kenderdine began his professional relationship with the University of Saskatchewan in 1923, when he was hired by Murray as its first 'artist-in-residence'. Kenderdine was also the university's first lecturer in art, teaching art classes beginning in 1926. In 1936 he established the Murray Point Art School at Emma Lake, which later became the famous Emma Lake Artists' Workshops.

In 1947 Kenderdine suffered a stroke during one of the art camps at Emma Lake, and later died in Regina. His works now form part of many public collections, including the Glenbow Museum (Calgary), the University of Saskatchewan permanent art collection, the MacKenzie Art Gallery (Regina), the Mendel Art Gallery (Saskatoon), and the National Gallery of Canada.

3. Associated Objects

The antlers above the cabin door have been there since before 1936, as a photograph from that year attests (Figure 3). Some furniture in the cottage is of unknown origin. These items include two tables, a chair and a dresser.

After Kenderdine's death in 1947, students affixed a bronze plaque reading 'Gus Kenderdine' to a rock, and situated it outside the lecture hall. In 1960, the lecture hall was demolished, the rock was moved, and now resides outside the Kenderdine studio cabin. Figure 15 shows Kenderdine's rock.

A sign reading 'Kenderdine' composed of paint on bark hangs beside the cabin door. This sign is not original and is of unknown origin.

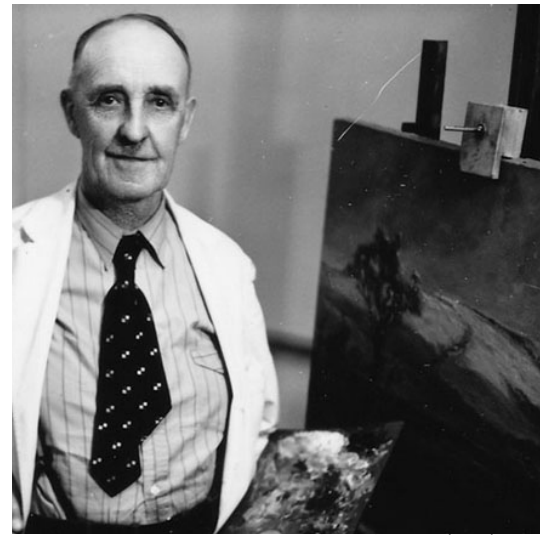

Figure 13. Augustus 'Gus' Kenderdine. Photo R-A7982, retrieved from http://esask.uregina.ca/entry/kenderdine_augustus_1870-1947.html



Figure 14. Table and chair inside the cabin.



Figure 15. Kenderdine's memorial stone.

4. Supporting Documents

Avery, C. (1999). Incentive to Vision: The Emma Lake Art Camp. *Art Libraries Journal* 24(3), 19-24.

Beamish, M. (after 1947). *How Murray Point Art Camp Began*. Retrieved from <http://scaa.usask.ca/gallery/murray/search/index.php?ID=54444&field=keywords&search=emma&page=2&part=5>

Facilities Management Division (2011). Asset Resource Database [Data File]. Retrieved from <\\usask\fmddfs\files\iis\IIS Public\ARS>

Hayden, M. (1983). *Seeking a Balance: University of Saskatchewan, 1907-1982*. Vancouver: University of British Columbia Press.

Trottier, P., personal communication, May 29, 2012.

University of Saskatchewan Archives, Controller's Office Fonds, 9, Series I. Vice President - Administration. II. Building Files, 15. Emma Lake Art Campus, 1949-66.

University of Saskatchewan Archives, Publications 52., Arts and Science (College), 3, Art 1. Calendars and Timetables.

University of Saskatchewan Archives, Publications 52., Arts and Science (College), 3, Art 2. Bulletins and Research Reports.

University of Saskatchewan Archives, Publications 52., Arts and Science (College), 3, Art 12. Histories.



5. Summary of Character-Defining Elements

Materials	<ul style="list-style-type: none">▪ spruce trim and log siding▪ cedar interior paneling
Form & Style	<ul style="list-style-type: none">▪ pitched roof▪ rectangular plan▪ log cabin▪ antlers
Location	<ul style="list-style-type: none">▪ Murray Point
Spatial Configuration	<ul style="list-style-type: none">▪ two rooms▪ pantry
Systems	<ul style="list-style-type: none">▪ log base
Uses	<ul style="list-style-type: none">▪ summer residence▪ art studio
Cultural & Chronological Associations	<ul style="list-style-type: none">▪ Augustus Kenderdine and his works▪ Kenderdine Art Campus

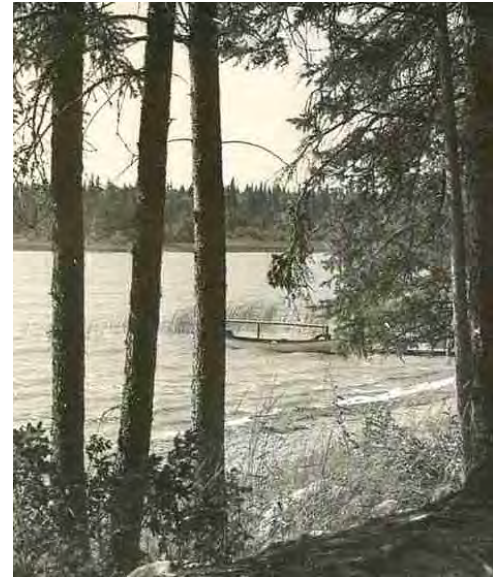

Palliser Garden

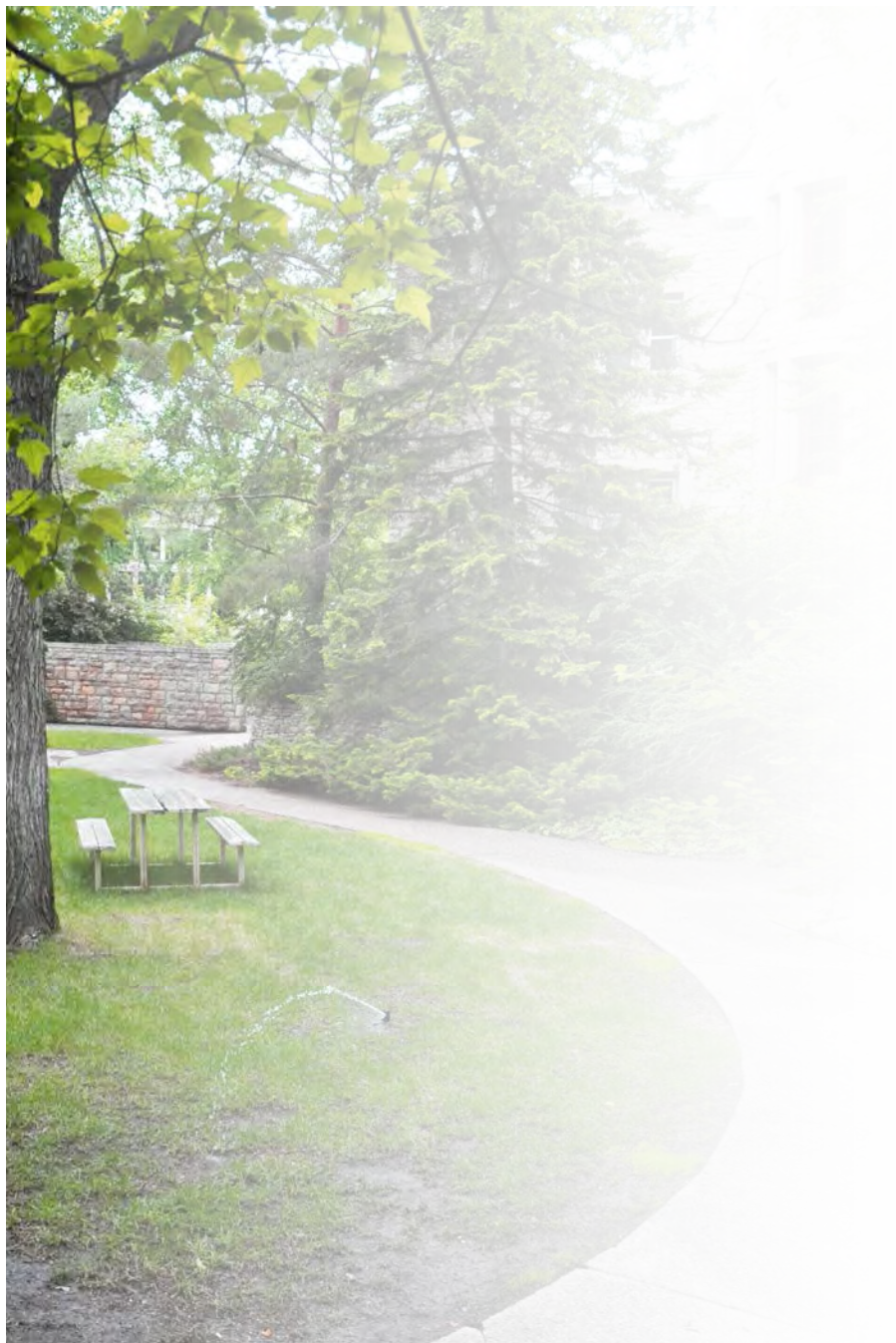

Palliser Garden

Alternate Names

Sunken Court

Architect(s)

Clive Justice and Harry Webb, Justice and Webb Landscape Architects, Vancouver

Builders

Unknown

Construction Dates

1921-1924, additions in 1966, 1988 and 2003

Recognition

University of Saskatchewan 'B' Listed



Figure 1. Materials defining the character of Palliser Garden: the greystone facade of Qu'Appelle Hall, steel balustrades, oak doors, pine and spruce trees.

1. Statement of Significance

Palliser Garden is a secluded landscaped courtyard at the University of Saskatchewan, located between [Qu'Appelle Hall](#) and Marquis Hall. Although it is not configured precisely as illustrated in the original 1909 Campus Plan, a similar courtyard was planned in the same location by university Architects David Brown and Hugh Vallance. The form of Palliser Garden was the result of the unfinished state of Qu'Appelle Hall and the later construction of Marquis Hall. Celebrated Vancouver landscape architects Clive Justice and Harry Webb undertook the landscape design of the garden in the mid 1960's as part of their work on the Marquis Hall project.

Palliser Garden has been used for events such as openings and performances as well as informal leisure and study by university students. Palliser Garden contains heritage value in its location, in its form as an outdoor room in keeping with the intent of the 1909 Campus Plan, and as a work of design by landscape architects Justice & Webb.

2. Character - Defining Elements

2.1 Materials

The exterior materials of the buildings around Palliser Garden define its material character to a large degree. Palliser Garden is formed by the materials, shape and character of two buildings from different periods of campus construction and is therefore influenced by two different material palettes. To the east, Palliser Garden is defined primarily by the rough-faced greystone, the limestone accents and the painted steel balustrades of [Qu'Appelle Hall](#) (Figure 1). To the west, the garden is characterised by the materials of Marquis Hall – smooth-faced Tyndall stone panels and aluminum-framed glazing (Figure 3). As shown in Figure 4, the garden has several retaining walls constructed in stone as well as a ramp flanked by a stone wall built of greystone and Tyndall stone. (For more information on building stones used at the U of S refer to [Appendix: Stone.](#))

The landscape features of the garden were designed by landscape architects Clive Justice and Harry Webb, who aimed for the garden to have an 'alpine' feel with lots of smaller plants. Character-defining plants include the spruce and pine trees shown in Figure 1. The use of trees without heavy foliage at eye level is another character-defining element allowing for visibility within the garden. Figure 3 depicts one of the trees chosen and planted in the middle of the space for this characteristic.



Figure 5. Palliser Garden as viewed from the east. Marquis Hall in the background makes up the western boundary. Photo retrieved from <http://www.flickr.com/photos/usask/5263879602/sizes/z/in/photostream/>



Figure 2. Top to bottom: Tyndall stone facade of Marquis Hall, Tyndall stone coping and greystone wall.



Figure 3. Materials defining the character of Palliser Garden: the Tyndall stone and the glazed facade of Marquis Hall, trees with trunks allowing visibility.



Figure 4. Materials defining the character of Palliser Garden: L to R: greystone retaining wall, foliage.



Figure 6. The location and form for the outdoor courtyard as intended by Brown and Vallance is indicated in green on the 1909 Campus Plan.

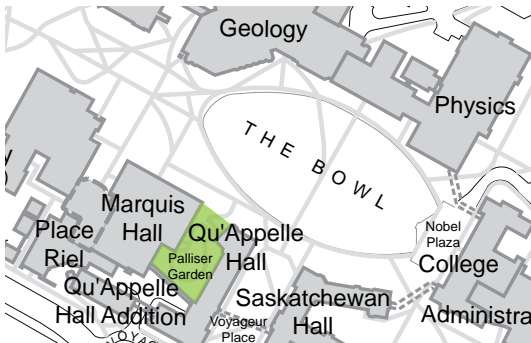

Figure 7. The existing location and configuration of Palliser Garden is indicated in green on this contemporary campus map.



Figure 8. Concrete steps and path surrounded by foliage intended to screen surrounding uses.

2.2 Form & Location

The form of Palliser Garden is the product of the unfinished state of [Qu'Appelle Hall](#) and the construction of Marquis Hall. University architects David Brown and Hugh Vallance specified a courtyard to the west of Qu'Appelle Hall (Figure 6). The courtyard was originally intended to be enclosed on three sides by the wings of Qu'Appelle Hall and was intended to remain open to the west. However, the northern wing of the building was never realized. In 1964, Marquis Hall was constructed to the west of Qu'Appelle Hall. The space left between Qu'Appelle Hall and Marquis Hall was landscaped to become Palliser Garden. The negative space between the two buildings largely determined the form of the garden (Figure 7).

2.4 Style & Spatial Configuration

Palliser Garden is asymmetrical in its spatial configuration. To the east, it is enclosed by the walls of Qu'Appelle Hall. It is open on its north side to [‘The Bowl’](#) and defined on the west side by Marquis Hall. The space is enclosed on its south side by a raised platform created by the partially buried tunnel connecting Marquis Hall and Qu'Appelle Hall. Figure 7 illustrates these boundaries. A concrete footpath encircles the space, and a set of steps allow access over the roof of the tunnel. Figure 8 shows the concrete steps and path. The garden is accessed from the north by a concrete ramp flanked by a stone wall (Figure 9).

Palliser Gardens is sunken in relation to the grade level immediately to the north. This quality gives it a more private atmosphere as does the heavy foliage around its perimeter. The foliage is used to screen visibility to the adjacent residence rooms in Qu'Appelle Hall and to the service court to the south. The sunken quality of the garden and the landscape design are character-defining elements which create privacy in the space. The screening foliage is visible in Figures 8 and 9.

The buildings forming the vertical boundaries of Palliser are Qu'Appelle Hall, which is designed in the Collegiate Gothic style, and Marquis Hall, which is a modernist building. The contrasting architectural styles of these buildings contribute to the character of the courtyard, although their scales are similar. The facade of Qu'Appelle Hall before the construction of Palliser garden is shown in Figure 10.

2.5 Use(s)

Palliser Garden is one of the more secluded outdoor spaces in the core of the campus. As such, it sees much less use than other outdoor areas such as [The Bowl](#) or [Voyageur Place](#). However, it is sought out by students looking for a quiet place to read or study. In warmer weather, gatherings such as openings and performances have taken place there.

Before its incorporation as Palliser Garden, the open space behind [Qu'Appelle Hall](#) was a vacant grassy lot. Historic photos show cars were sometimes parked there. Figure 10 shows the area of Palliser Garden before it was landscaped.

2.6 Cultural & Chronological Associations

Palliser Garden is named for John Palliser. Palliser was an Irish-born geographer and explorer who led an expedition to the Canadian west between 1857 and 1861 on behalf of the British government. He was instrumental in ending the ownership of Rupert's Land by the Hudson's Bay Company through the 1869 Deed of Surrender. He also declared a southwest region of Saskatchewan too arid for agriculture and named it Palliser's Triangle. This did not deter settlers from farming there. He is credited with helping to bring development and settlement to the Canadian prairies.

Palliser Garden is also associated with the work of landscape architects Clive Justice and Harry Webb. Justice and Webb were pioneering landscape architects of the mid-twentieth century in British Columbia. Some of the firm's notable projects included the University of British Columbia's Botanical Gardens and the Van Dusen Gardens in Vancouver.



Figure 9. Greystone wall and ramp.



Figure 10. The site of Palliser Garden before the construction of the Qu'Appelle Hall Addition or Marquis Hall. Retrieved from University of Saskatchewan Archives, Justice and Webb Fonds.

3. Associated Objects

N/A

4. Supporting Documents

Author Unknown. (May 18, 2007). The Spaces in Between. *On Campus News*, Retrieved from http://news.usask.ca/archived_ocn/07-may-18/24.php

Avery, C. (2007). Oasis for Learning: Landscaping the University of Saskatchewan. *Saskatoon History Review*, 21, 11-24.

Facilities Management Division (2011). Asset Resource Database [Data File]. Retrieved from \\usask\fmddfs\files\iis\IIS_Public\ARS.

University of Saskatchewan Archives. Justice and Webb Fonds. MG 197 I. Working Files U13.1 Marquis Hall (Qu'Appelle Hall Addition) - 1962-1963.



5. Summary of Character-defining Elements

Materials

- greystone façade, walls and retaining walls
- grass
- trees: spruce, pine
- small plants
- glazing
- Tyndall stone

Form & Location

- asymmetrical
- University of Saskatchewan
- between Marquis and Qu'Appelle Halls

Style & Spatial Configuration

- ramp and stairs
- closed on three sides by the facades of Qu'Appelle and Marquis Halls
- sunken
- trees with visibility at trunk height

Uses

- privacy
- reading, study
- small gatherings (openings, performances)

Cultural & Chronological Associations

- John Palliser
- Landscape architects Clive Justice and Harry Webb

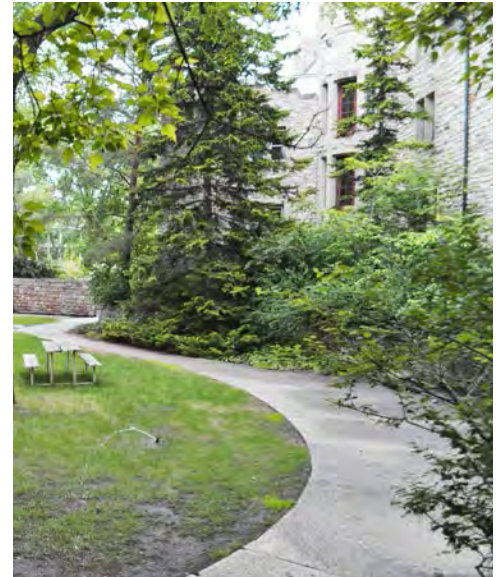

University of Saskatchewan Heritage Register

8. Supporting Documents



UNIVERSITY OF
SASKATCHEWAN

Facilities Management
Division



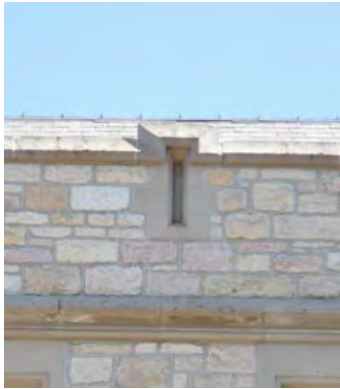

Figure 1. Archer slot.

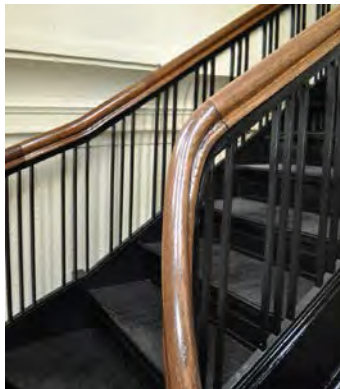

Figure 2. Balustrade.

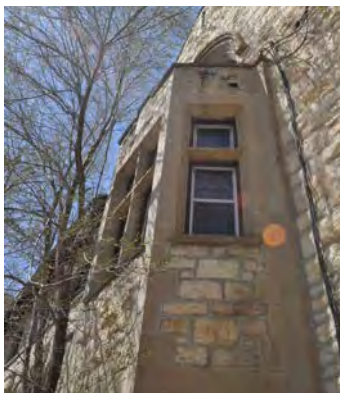

Figure 3. Bay window.



Figure 4. Brackets.

8.1 Glossary

- **Apse:** A vaulted, semicircular or semipolygonal wall recess or extension of a hall, such as on the short side of an ancient Roman basilica or at the sanctuary end of a Christian church (Figure 8).
- **Arcade:** 1. A series of arches on columns or piers, either freestanding or attached to a wall. 2. A covered walk with a line of such arches on one or both sides.
- **Arch:** A curved structure, usually made of wedge-shaped stones (voussoirs) that spans an opening.
- **Archer Slot:** A narrow opening in a parapet or battlement. Archer slots were devised to offer a well-protected offensive vantage point from which missiles could be fired. A decorative architectural feature modelled on the appearance of a functional archer slot (Figure 1).
- **Arts and Crafts Style:** An international design movement that enjoyed popularity between 1860 and 1910. It promoted traditional craftsmanship using simple forms and often saw the application of medieval, romantic or folk styles of decoration
- **Ashlar Masonry:** Smooth, squared stones laid with mortar in horizontal courses.
- **Axis:** An imaginary straight line about which parts of a building or a group of buildings are arranged.
- **Balustrade:** A railing supported by a series of small posts or balusters (Figure 2).
- **Barrel Vault:** A continuous, semicircular vault extending in a straight line.
- **Base:** The lowest supporting part of a column, pier or wall.
- **Basilica:** 1. In ancient Roman architecture, a large meeting hall, often oblong in plan, with a high central space lit by clerestory windows. 2. The form of an Early Christian church, oblong, with a high clerestoried nave ending in an apse, flanked by two lower aisles, and covered with a timber roof.
- **Battlement:** A series of alternate openings and solid portions on top of a wall, characteristic of castles. Also called crenellation (Figure 9).
- **Bay:** A regularly repeated spatial unit of a building or wall as defined by vaults, windows, orders or other prominent vertical features.
- **Bay window:** A projecting window, usually rising from the ground (Figure 3).

- **Bracket:** A projection from a vertical surface providing support under cornices, balconies, window frames etc (Figure 4).
- **Buttress:** An additional support projecting from, or built against a wall. Also called a pier (Figure 20).
- **Casement Window:** A window hinged at the sides that opens usually inward and outward (Figure 5).
- **Chancel:** The end of a Christian church that has the principal altar, usually the east end beyond the crossing (Figure 8).
- **Chapel:** A room or building within a larger complex used for Christian religious purposes (Figure 8).
- **Choir:** The part of a Christian church where the choir sits. It is usually the west part of the chancel, between the altar and the crossing, although the term is sometimes used to mean the same as chancel (Figure 8).
- **Church:** The principal Christian religious building, used in public worship (Figure 8).
- **Clerestory:** An elevated range of windows in a wall that rises above adjacent roofs (Figure 6).
- **Cloisonne:** An enameling process in which strips of metal (cloisons) are soldered to a base, forming compartments into which enamel is poured and fused (Figure 7).
- **Cloister:** A covered walk around a monastery or courtyard, or the whole courtyard and walkway complex.



Figure 5. Casement window.

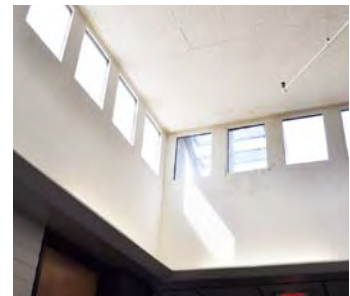

Figure 6. Clerestory windows.



Figure 7. Doors featuring the cloisonne enameling process.

Figure 8. Common characteristics of the Christian church. Retrieved from, Kostof, S. (1985). *A History of Architecture: Settings and Rituals*. Oxford University Press: Oxford.

1. Nave
2. Aisle
3. Crossing
4. Choir
5. Transept
6. Chancel
7. Apse
8. Ambulatory
9. Radiating Chapel

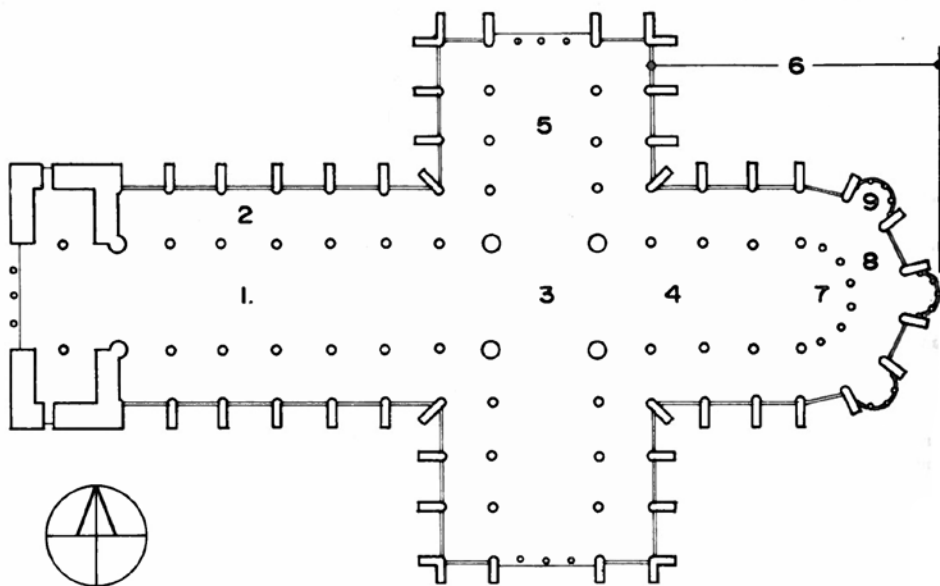



Figure 9. Crenellation or battlement.



Figure 10. Cupola.

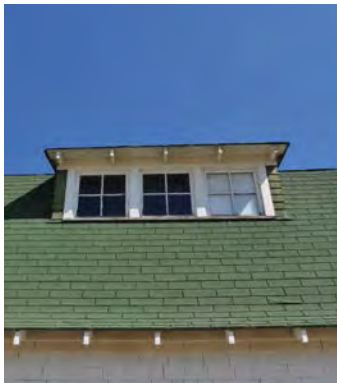

Figure 11. Dormer window.



Figure 12. Foliage.

- **Collegiate Gothic Style:** An architectural style used particularly for college and university buildings in North America in the late 19th and early 20th centuries. Collegiate Gothic was a branch of the Gothic Revival movement of the 19th and early 20th centuries, which sought to re-establish principles of mediaeval art and architecture. The Collegiate Gothic style was used to associate newer North American universities with the history and traditions of their older European predecessors. Characteristics include: brick and stone used as principal materials, arches, buttresses, dormers, crenellation or battlements, finials, gargoyles, grotesques, heraldry, quoining, relief sculptures, stone tracery, bay and oriel windows.
- **Colonnade:** A row of columns supporting a beam or entablature.
- **Column:** A vertical support.
- **Crenellation:** A pattern of repeated depressed openings (crenels) in a fortification wall. Historically, crenellation was used to provide firing positions along the top of a defensive wall and to give cover to defending archers and crossbowmen (Figure 9). Also called a battlement.
- **Crossing:** The place where the arms of the cross intersect in a church with a cross shaped plan (Figure 8).
- **Cupola:** A small dome, particularly a dome atop a roof or small tower (Figure 10).
- **Dome:** A convex roof or even curvature on a circular or polygonal base. It can be semicircular, pointed or bulbous in section.
- **Dormer Window:** A window that projects vertically from a sloping roof and has a roof of its own (Figure 11).
- **Double Arch:** Arch erected from two centres, with radii shorter than half the span.
- **Eave:** The lower part of a sloping roof projecting beyond a wall.
- **Finial:** An ornament that tops a pinnacle, spire, etc., usually pointed and decorated with stylized foliage.
- **Flying Buttress:** An arch or half arch that transfers the thrust of a vault or roof from an upper part of a wall to a lower support.
- **Foliage:** An ornamental representation of leaves, stems, and flowers.
- **Frieze:** The middle of the three main divisions of an entablature or any long, narrow, horizontal panel or band used for decorative purposes.

- **Gable:** The upper, usually triangular, part of a wall below the end of a roof with two sloping sides.
- **Gambrel Roof:** A two-sided roof with two slopes on each side (Figure 13).
- **Gargoyle:** Ornament, usually a fantastic creature, projecting from a building; a decorated water spout projecting from a building.
- **Groin Vault:** Formed by the right angle intersection of two barrel vaults of the same shape Also called a cross vault.
- **Gothic Arch:** A pointed arch consisting of two curves with a point at the top (Figure 14).
- **Grotesque:** A carved or painted decoration representing a fantastic creature (Figure 15).
- **Guastavino Vault:** A technique for constructing robust, self-supporting arches and architectural vaults using thin, interlocking terracotta tiles and layers of mortar to form curved horizontal surfaces. Patented in 1885 by Spanish architect Rafael Guastavino, the system is also known as the 'Guastavino Tile Arch System.'
- **Heraldry:** The use, display, and regulation of hereditary symbols employed to distinguish individuals, armies, institutions, and corporations. These symbols originated as identification devices on flags and shields.
- **Historicism:** The use of forms from a variety of past styles, either separately or in combination, particularly during the last two centuries.
- **Horseshoe Arch:** An arch shaped like a rounded or pointed horseshoe with a diameter at its widest point greater than the opening it spans (Figure 22).
- **Inglenook:** Common in the 17th century, a wooden seat built into the space on either side of a wide fireplace. Inglenooks fell out of favour with the more sophisticated flues, which allowed for smaller fireplaces, but were reintroduced with the revival of cottage-style architecture in the late 19th century.
- **Keystone:** The central wedge-shaped stone in an arch, sometimes decorated. As a structural member, used to stabilize the other stones in an arch. In contemporary times, keystones are sometimes used for ornamentation rather than structural purposes and can be found as the central stone in a series of horizontal stones (Figure 16).
- **Lancet Window:** A narrow window, topped with a pointed arch.

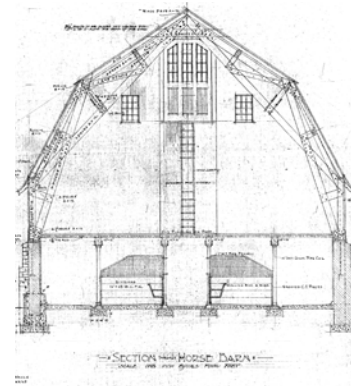

Figure 13. Gambrel roof shape.

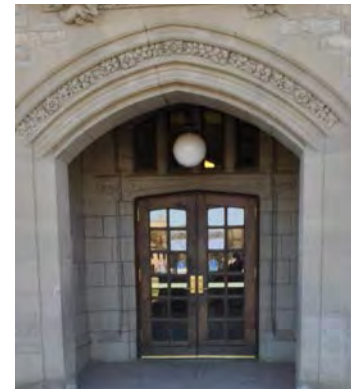

Figure 14. Gothic arch.

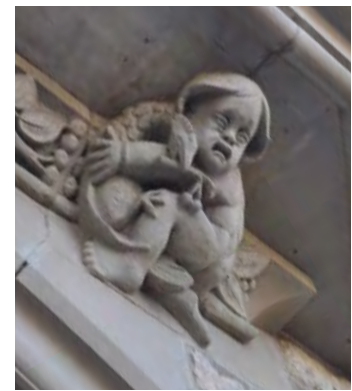

Figure 15. Grotesque.



Figure 16. Keystone.



Figure 17. A leaded glass window; lites separated by lead glazing bars.



Figure 18. Oriel window.

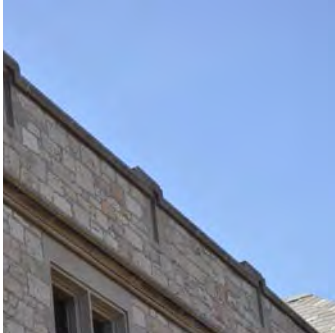

Figure 19. Parapet with archer slots and crenellation.



Figure 20. Pier.

- **Leaded Glass Windows:** Windows in which separate glass lites have been soldered together with lead glazing bars (Figure 17).
- **Lintel:** A horizontal beam or stone that spans an opening.
- **Lites:** Small panes of glass separated by wooden or lead glazing bars, often arranged in a decorative glazing pattern dictated by the buildings architectural style (Figure 17).
- **Masonry:** Stonework or brickwork.
- **Moat:** A wide protective ditch surrounding a medieval town or fortress, sometimes filled with water.
- **Modern Style:** A style of architecture, with origins in Europe, which roughly spanned the time between the first World War until the 1970's. The central principles of modernism were defined by the Congress Internationale d'Architecture Moderne (CIAM) in the 1933 Athens Charter and included the subordination of private interests to collective interests, the rejection of historical styles and ornamentation and a focus on function. Characteristics of the modern style include: functional forms, linearity, exposed or expressed structure, open floor plans, a lack of ornamentation, a focus on materiality, post and beam construction, material and volumetric intersection and extension.
- **Molding:** A contoured, decorative band applied to a wall surface or to the edge of a building part.
- **Monastery:** The building complex of a monastic order.
- **Nave:** In a Christian church, the middle part of the western arm extending from the entrance to the crossing and flanked by aisles (Figure 8).
- **Oriel Window:** A medieval window that projects from an upper floor (Figure 18).
- **Parapet:** A low guarding wall at the edge of a point of sudden drop, such as a roof, terrace, balcony or bridge (Figure 19).
- **Pier:** A solid masonry support, often rectangular or square in plan (Figure 20).
- **Post and Beam:** A construction system using vertical supports (posts) spanned by horizontal beams (also called lintels).

- **Postmodern Style:** An architectural style arising as a reaction to dissatisfaction with the modern architectural movement, especially in North America. The postmodern style enjoyed popularity from the 1970's until the end of the 20th century when an appreciation for modern principles was renewed. Characteristics of the postmodern style include the use of historical elements and/or ornamentation with in conjunction with tenets of the modern style.
- **Quarry-Faced Masonry:** Composed of square blocks with rough faces, as if it came directly from the quarry. Also known as stone or rock-faced masonry.
- **Quatrefoil:** Four lobed, leaf-shaped, indented spaces which are found especially in the tracery of gothic windows.
- **Quoin:** One of a series of stones or bricks used to mark the corners of a building, often through a contrast of size, shape or color (Figure 21).
- **Rafter:** One of a series of sloping beams supporting a pitched roof.
- **Relief:** Carved or embossed decoration raised above a background plane (Figure 22).
- **Revival:** The use of older styles or forms in new architecture.
- **Rib:** A narrow, projecting band on a ceiling or vault, usually structural, but sometimes merely decorative.
- **Rusticated Masonry:** Blocks separated from each other by deep joints, often wedge-shaped grooves.
- **Rustication:** The separation of regular masonry blocks by deeply cut, often wedge-shaped grooves.
- **Sacristy:** A room in a Christian church where altar vessels and robes are stored.
- **Sanctuary:** The area around the principal altar in a Christian church.
- **Sash Window:** A window that opens by sliding up or down.
- **Scupper:** An opening for draining off water, as from a floor or the roof of a building (Figure 23).
- **Spandrel:** The area between the sill of a window and the head of the window below it.
- **Statuary Niche:** An ornamental recess in a wall or the like, usually semicircular in plan and arched, as for statue or other decorative object (Figure 24).

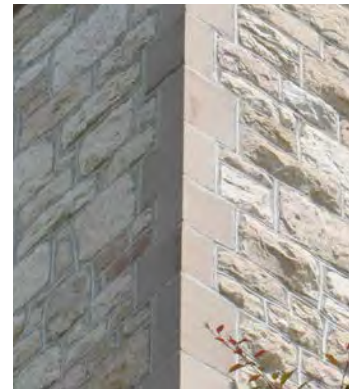

Figure 21. Quoining.



Figure 22. Relief carving with a motif of horsehoe arches.

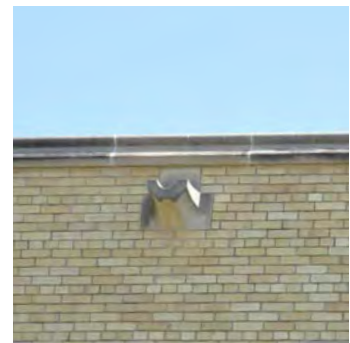

Figure 23. Scupper.



Figure 24. Statuary niche.



Figure 25. String course.



Figure 26. Tracery.

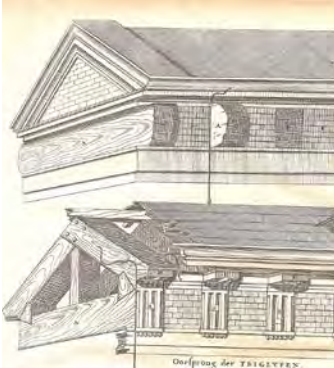

Figure 27. Triglyphs.



Figure 28. Ceiling vault.

- **String Course:** A projecting horizontal band across an exterior wall of a building (Figure 25).
- **Terracotta:** Hard, molded, and fired clay used for ornamental wall covering, or roof or floor tile.
- **Tongue and Groove:** A wood-joining method in which a long, slightly projecting tongue of one member fits into the correspondingly shaped long narrow groove of another member.
- **Tracery:** A pattern of curvilinear, perforated ornament within the upper part of a medieval window or screen (Figure 26).
- **Transept:** The transverse arms of a cross-shaped church, crossing the main axis at a right angle (Figure 8).
- **Transom:** A horizontal member or bar separating a door from the window or spandrel above it.
- **Transom Window:** The window above a transom.
- **Trefoil:** Three lobed, leaf-shaped, indented spaces which are found especially in the tracery of gothic windows. A three lobed, foliated arch is a trefoil arch.
- **Triglyph:** A projection consisting of three vertical bands separated by grooves that alternate with receding square panels. Classically located on the frieze, triglyphs are a feature of the Doric order of architecture. Triglyphs are stylized descendants of the wooden beam ends that supported the roofs of Greek temples (Figure 27).
- **Turret:** A round, rectangular or polygonal projection from a wall.
- **Vault:** An arched ceiling or roof (Figure 28).

Supporting Documents for Glossary:

Kostof, S. (1985). *A History of Architecture: Settings and Rituals*. New York: Oxford.

Bose, S. (May/June 2008). What is Modernism? *Preservation*, . Retrieved from <http://www.preservationnation.org/magazine/2008/may-june/what-is-modernism.html>

Brooks, C. (1999). *The Gothic Revival*. London: Phaidon.

Curl, J.S.. (2000). Double Arch. In *A Dictionary of Architecture and Landscape Architecture*. Retrieved from <http://www.encyclopedia.com/doc/1O1-doublearch.html>

Encyclopædia Britannica Academic Edition.
Retrieved from <http://www.britannica.com>

Encyclopeida.com. Retrieved from <http://www.encyclopedia.com/doc/1O1-doublearch.html>

Simmins, G. (2012). Collegiate Gothic and Other Revival Styles in 20th Century Canadian Architecture. In *The Canadian Encyclopedia*. Retrieved from <http://www.thecanadianencyclopedia.com/articles/collegiate-gothic-and-other-revival-styles-in-20thcentury-canadian-architecture>

8.2 Bibliography

- Anderson, D. (Retrieved 2012). *The Encyclopedia of Saskatchewan, Mitchell, John (1897-1955)*. Retrieved from http://esask.uregina.ca/entry/mitchell_john_1897-1955.html
- Anonymous. (2011, May 23). *Rugby Chapel*. Retrieved from http://en.wikipedia.org/wiki/Rugby_Chapel
- ArtSask 2012. (Retrieved 2012). *Ernest Lindner*. Retrieved from <http://www.artsask.ca/en/artists/ernestlindner>
- Assier, Robert (Tesella Stone Carvers). (2003). *Report on Thorvaldson Building Exterior Masonry*. Retrieved from Facilities Management Division.
- Author Unknown. (1967, April 13). Another Call for Help from the Little Stone School. *The Western Producer*, pp. 41. SK Archives Board.
- Author Unknown. (April 29, 2005). College of Emmanuel & St. Chad likely to close. *On Campus News*, 12. Retrieved from <http://www.usask.ca/communications/ocn/o5-apr-29/news03.shtml>.
- Author Unknown. (2011). *College of Engineering: History*. Retrieved from <http://www.engr.usask.ca/aboutus/history.php>
- Author Unknown. (1967, November-December). Colleges in Construction: Law Building Officially Opened. *Canadian University*, 48-49.
- Author Unknown. (1966, November 28). Committee Reports Progress on Refurnishing First School. *The Saskatoon Star Pheonix*, pp. 11. Saskatchewan Archives Board Little Stone School Society of Saskatoon fonds, A377. SK Archives Board.
- Author Unknown. (October 29, 1929). Emmanuel College Celebrates Jubilee. *The Saskatoon Star Phoenix*, pp. 6. SK Archives Board.
- Author Unknown. (October 5, 1928). Gates of Glory. *Winnipeg Free Press*, pp.17. Retrieved from <http://archiveswinnipegfreepress.com/RegistrationLockdown.aspx?ctl=search&returnurl=Search.aspx>
- Author Unknown. (Retrieved 2012). *John Diefenbaker - Wikipedia*. Retrieved from http://en.wikipedia.org/wiki/John_Diefenbaker
- Author Unknown. (October 2, 1998). Makahonuk Memorial Located on Campus. *On Campus News*, 6(3). Retrieved from http://news.usask.ca/archived_ocn/Oct2-98/news5.html
- Author Unknown. (Retrieved 2012). *Monastic Enclosures*. Retrieved from <http://www.encyclopedia.com/doc/1o245-monasticeenclosures.html>

- Author Unknown. (October 7, 2005). Moose Moves into Residence. *On Campus News*, 13(4). Retrieved from http://news.usask.ca/archived_ocn/05-oct-07/news02.shtml
- Author Unknown. (September 1, 2000). New plaque marks Dief's grave. *On Campus News* 8(1). Retrieved from http://news.usask.ca/archived_ocn/sept1-00/news12a.shtml
- Author Unknown. (Retrieved 2012). *Our History - St. Andrew's College*. Retrieved from <http://www.usask.ca/stu/standrews/about-us/our-history.php>
- Author Unknown. (March 8, 2008). Raising the Roof on Kirk Hall. *On Campus News*, 15(14). Retrieved from http://news.usask.ca/archived_ocn/08-mar-28/2.php
- Author Unknown. (1967, June 2). Refurnished Historical Old Stone School Officially Opened. *Saskatoon Star Phoenix*, pp. 9. SK Archives Board.
- Author Unknown. (1929, June 13). Rugby Chapel. *The Canadian Churchman*, pp. 387. SK Archives Board.
- Author Unknown. (Retrieved 2012). *Sacred Destinations: Merton College, Oxford*. Retrieved from <http://www.sacred-destinations.com/england/oxford-merton-college-map-plan.htm>
- Author Unknown. (Aug 17, 1979). State Funeral Set for Diefenbaker. *The Globe and Mail*, retrieved from <http://v1.theglobeandmail.com/series/primeministers/stories/obit-JD.html>
- Author Unknown. (October 5, 2007). Studio Declared Heritage Site. *On Campus News*. Retrieved from http://news.usask.ca/archived_ocn/07-oct-05/12.php
- Author Unknown. (June 13, 1929). The College of Shacks. *Canadian Churchman*, pp 376. SK Archives Board.
- Author Unknown. (June 13, 1929). The Future of Emmanuel College: A Challenge and an Appeal. *Canadian Churchman*, pp 383. SK Archives Board.
- Author Unknown. (January 23, 2009). The Last Will and Testament of Cecil George Harris. *On Campus News*, . Retrieved from http://news.usask.ca/archived_ocn/09-jan-23/see_what_we_found.php
- Author Unknown. (May 18, 2007). The Spaces in Between. *On Campus News*. Retrieved from http://news.usask.ca/archived_ocn/07-may-18/24.php

- Author Unknown. (Spring 2013). Tell us your Swimming Pool Stories! *Green and White*. Retrieved from <http://www.usask.ca/greenandwhite/issues/2002/winter2002/features/feature06.php>
- Author Unknown. (June 13, 1929). The Theological College and the Student. *Canadian Churchman*, pp 377-381. SK Archives Board.
- Author Unknown. (October 19, 2007). Tour Explores Creepy Part of Campus. *On Campus News*. Retrieved from http://news.usask.ca/archived_ocn/07-oct-19/14.php
- Author Unknown. (Winter 2006). Visiting Kirk Hall. *The Green and White*. Retrieved from <http://www.usask.ca/greenandwhite/issues/2006/winter2006/features/alumnews.php>.
- Author Unknown. (1947, September 16). Welcome Program. *The Sheaf*, pp. 2.
- Author Unknown. (n.d.). *Who Owns Emmanuel College?* (Unpublished dissertation). College of Emmanuel and St. Chad, Saskatoon. SK Archives Board.
- Avery, C. (1999). Incentive to Vision: The Emma Lake Art Camp. *Art Libraries Journal* 24(3), 19-24.
- Avery, C. (2007). Oasis for Learning: Landscaping the University of Saskatchewan. *Saskatoon History Review*, 21, 11-24. Call no. FC3547.4.S28no.212007.
- Beamish, M. (after 1947). *How Murray Point Art Camp Began*. Retrieved from <http://scaa.usask.ca/gallery/murray/search/index.php?ID=54444&field=keywords&search=emma&page=2&part=5>
- Bell, J.M. (1996). *Hoofprints to Reprints: The History of Animal Husbandry, Animal Science and Animal and Poultry Science, University of Saskatchewan 1909-1989*. Saskatoon: The College of Agriculture, University of Saskatchewan. Call no. LE3.S72B451996.
- Brown, D. (1924). The University of Saskatchewan, Saskatoon. *The Journal Royal Architectural Institute of Canada*, Oct.-Dec.,109-121.
- Buchan, D.J. (1983). *Greenhouse to Medical Centre: Saskatchewan's Medical School 1926-78*. Saskatoon: University of Saskatchewan. Call no. R749.S2B81983.
- Calhoun, P.J. (Retrieved 2012). *The Encyclopedia of Saskatchewan, Gruchy, Lydia E. (1894-1992)*. Retrieved from http://esask.uregina.ca/entry/gruchy_lydia_e_1894-1992.html

College of Dentistry. (Retrieved 2012). *History of the College*. Retrieved from <http://www.usask.ca/dentistry/about/history.php?heading=menuAbout>

Christensen, D. Personal Communication. July 10, 2012.

The City of Saskatoon. (Retrieved 2011). *Little Stone School House*. Retrieved from <http://www.saskatoon.ca/DEPARTMENTS/Community%20ServicePlanningDevelopmentDevelopmentReview/HeritageConservation/HeritageProperties/PagesLittleStoneSchoolHouse.aspx>

Culture, Youth and Recreation Saskatchewan. (2003). *Provincial Heritage Property Information Kit for the College Building*, U of S., Saskatoon.

Currie, B. (1976). *The Physics Department 1910-1976 University of Saskatchewan*. Saskatoon: University of Saskatchewan.

Dallas, Z. (1973, August 18). The Little Stone School. *The Star Phoenix*, pp. 14. SK Archives Board.

Delaney, W.P., Duerkop, J.D. & Sarjeant, W.A.S. (1982). *Saskatoon: A Century in Pictures*. Saskatoon: Western Producer Prairie Books. Call no. FC3547.37D46.

Diamond, E. (1994). *Saving Our City: Saskatoon's Protected Heritage Structures*. Youngberg, G., (Ed.). Saskatoon: Municipal Heritage Advisory Committee, City of Saskatoon. Call no. FC3547.7.D431994c.3.

The Diefenbaker Centre (2011). *Tour Information for The Little Stone School House*. Saskatoon, SK: Leland MacLachlan.

Ed. Department of Education (15) General Correspondence (1922-1940). SK Archives Board.

Eyre, W. (September 5, 1997). From the University Archives: A Brief History of Frosh Week. *On Campus News*, . Retrieved from http://news.usask.ca/archived_ocn/Sept5/archives.html

Facilities Management Division (2011). Asset Record System [Data File]. Retrieved from \\usask\fmddfs\files\iis\IIS_Public\ARS

Facilities Management Division. (n.d.) *President's Residence Building Audit*. Retrieved from Facilities Management Division.

Fast, B. (2012). *E is for Engineering: 100 Years*. Saskatoon: College of Engineering.

Genivar Inc. (2011). *Stone Barn Structural Investigations and Recommendations*. Retrieved from Facilities Management Division.

- Greene, D.L. (June 13, 1929). Loves Coronation. *Canadian Churchman*, pp. 378, 379. SK Archives Board.
- Gruending, D. (Retrieved 2013). *The Encyclopedia of Saskatchewan, Hall, Emmett 1898-1996*. Retrieved from http://esask.uregina.ca/entry/hall_emmett_1898-1996.html
- Gustafson, G. (2002). *Exploring the Wonder City: A Historic Driving Tour of Saskatoon*. Saskatoon: City of Saskatoon Municipal Heritage Advisory Committee. Call no. FC3547.18.G872002.
- Hanson, S. (2000). *Dictionary of Canadian Biography Online: Rutherford, William John*. Retrieved from http://www.biographi.ca/009004119.01e.php?&id_nbr=7963&&PHPSESSID=ychzfqkvzape
- Hanson, S. (1985). The Administration Building. *Saskatoon History*, 3, 4-10. Call no. FC3547.4.S28no.31985.
- Hartl, C., Personal Communication, September 9, 2013.
- Hayden, M., Pitsula, J. & Blake, R. (2003). Saskatchewan's Universities – A Perception of History, *The Saskatchewan Institute of Public Policy Public Policy Paper Series* (Paper 15). Call no. EDUC.LC176.2.S27H292003.
- Hayden, M. (1983). *Seeking a Balance: University of Saskatchewan, 1907-1982*. Vancouver: University of British Columbia Press.
- Hayden, M. (1980). Where the 20's Didn't Roar – The University of Saskatchewan, 1920-1930, *Saskatoon History*, 1, 13-21. Call no. FC3547.4.S28no.11980.
- Hayes, P. (2009). A Bowl Full of History, *On Campus News*, 16(12) 3.
- Hayes, P. (January 23, 2009). From the Archives: The Big Jump. *On Campus News*. Retrieved from http://news.usask.ca/archived_ocn/09-jan-23/fromthearchives.php
- Hayes, P. (March 18, 2005). From the University Archives 'U Museum' Idea Has Long History. *On Campus News* 12(14). Retrieved from http://news.usask.ca/archived_ocn/05-mar-18/column_archives.shtml
- Hayes, P. (September 23, 2005). Gates Were Early Campus Entrance. *On Campus News* 13 (3). Retrieved from http://news.usask.ca/archived_ocn/05-sep-23/column_archives.shtml
- Hayes, P. (April 20, 2007). Playing the Part of Host. *On Campus News*. Retrieved from http://news.usask.ca/archived_ocn/07-apr-20/4.php

- Heiber, K. (1984). *The Greystone Review '84: 75 Years of Students at the U of S*. Saskatoon:1984. Call no. LE3.S74H431984.
- Herrington, R. (March 1, 2008). *Statement of Heritage Significance Borden (Ceepee) Bridge*. Retrieved from <http://www.tpcs.gov.sk.ca/BordenBridge>
- Holliday-Scott, J., Personal Communication, September 5, 2013.
- Hutchinson, T., Personal Communication, 2012.
- Jasienuk, T., Personal Communication, August 17, 2012.
- Johnson, A.E. (1929, June 13). Unmeasured Debt of the Church in Western Canada to the Colonial and Continental Church Society. *Canadian Churchman*, pp. 375. SK Archives Board.
- Kerr, D. (1980). Building the University of Saskatchewan 1907-1930. *Prairie Forum*, 5 (2), 157-181.
- Kerr, D. (2012). *University of Saskatchewan Faculty Club: The Story*. Saskatoon: University of Saskatchewan.
- Kerr, D. (2011, Summer). John Holliday-Scott Designed U of S Law Building and Wascana Place. *Worth: Saskatchewan's Architectural Heritage Magazine*, 28 (2),18-19.
- Kerr, D. & Hanson, S. (1982). *Saskatoon: The First Half-Century*. Edmonton: NeWest Press. Call no. FC3547.4.K47c.8.
- Kerr, D. & Tennent, C. (2006). The College Building. *Saskatoon History Review*, 20, 1-6.
- Kirkham, Willis. (2012). The Northeast Swale and Early University of Saskatchewan Buildings. *Report to the Meewasin Valley Authority*.
- Lemhukl, P. (Producer). (2013, September 3), *U of S Campus Observatory: A Brief History*. Saskatoon, SK: Youtube. Retrieved from <http://www.youtube.com/watch?v=oD-7FbjjUoo>
- Lewry, M. (Retrieved 2011). *The Encyclopedia of Saskatchewan, Rutherford, William John*. Retrieved from http://esask.uregina.ca/entry/rutherford_william_john_1868-1930.html
- Lexier, R. (2007). The Backdrop Against Which Everything Happened. *History of Intellectual Culture*, 7 (1). Retrieved from <http://www.ucalgary.ca/hic/issues/vol7/3>
- The Little Stone School Society (1974). *The Little Stone School*. Saskatoon, SK: Jessie Caldwell. SK Archives Board.

- Lomheim, S. (2011). *Gates of Glory*, *Saskatoon History Review*, 24, 28-31. Call no. FC3547.4.S28no.242011.
- Macdonald, R. H. (1982). *Thorough: An Illustrated history of the College of Engineering, University of Saskatchewan, 1912-1918*. Saskatoon: College of Engineering. Call no. LE3.S72M34 (Engineering Stacks).
- Macdonald, R.H. (1965, December 2). WP Photocolor Section. *The Western Producer*, pp. C1. SK Archives Board.
- MacPherson, C. (October 18, 2002). Campus Final Resting Place for At Least 3 Souls. *On Campus News*, 10(5). Retrieved from http://news.usask.ca/archived_ocn/07-oct-05/12.php.
- MacPherson, C. (September 13, 2013). Gates Repaired, Missing Names Finally Added. *On Campus News* 21(2). Retrieved from http://news.usask.ca/wp-content/uploads/2013/09/2013-09-13_web.pdf
- MacPherson, C. (September 5, 2008). In Praise of Older Buildings. *On Campus News* 16(2). Retrieved from http://news.usask.ca/archived_ocn/08-sept-05/editornote.php.
- Macpherson, J. (n.d.). *A Member of 1895's Grade 4 Class Comes to Visit*. SK Archives Board.
- McGowan, T. (1994, January 20). This week in Photos. *The Sheaf*, pp.9.
- McMahen, L. (September 5, 2009). Green Roof Study Underway on Dentistry Building. *On Campus News* 13(2). Retrieved from http://news.usask.ca/archived_ocn/05-sep-09/news12.shtml
- Mitsui, E. (2012, August 24). *Life in The Arctic: Where Old Ways and New Collide*. CBC News. Retrieved from <http://www.cbc.ca/news/canada/story/2012/08/23/f-arctic-cambridge-bay-life.html>
- Morton, A.S. (1959). *Saskatchewan: The Making of a University*. C. King, (Ed.). London: University of Toronto Press. Call no. Educ. LE3.S72M8c.2
- Morton, Arthur Silver. (1934-1937). *Written in Letters of Gold: A.S. Morton's History of the University of Saskatchewan's First 25 Years*. Retrieved from http://www.usask.ca/archives/history/Essays2006_Morton.pdf.

- Morton, Arthur Silver. (1959). *Saskatchewan: The Making of a University*. Toronto: University of Toronto Press.
- Murray, D.R. & Murray, R.A. (1984). *The Prairie Builder: Walter Murray of Saskatchewan*. Edmonton: NeWest Press.
- Murray, W.C.. (Jun 13, 1929). Emmanuel and the University of Saskatchewan. *Canadian Churchman*, pp 384. SK Archives Board.
- Murray, W. (1941). *The University of Saskatchewan*. S.I.: s.n. Call no. LE3.S72M89 (Special Collections).
- Mushka, C. (July 4, year unknown). Little Stone School S.D. No. 13 Northwest Territories 1887. *The Sheaf*, pp. 4(52), 5(53). SK Archives Board.
- Mysyk, W.K. & Kulyk, C.L. (2006). *Saskatoon's Stone*. Saskatoon: Houghton Boston Printers & Lithographers Ltd.
- O'Brien, J., Millar, R.W. & Delainey, W.P. (2006). *Saskatoon: A History in Photographs*. Regina: Coteau Books. Call no. FC3547.37.O.272006c.3.
- Office of the University Secretary. (Retrieved 2012). *Ceremonies and Protocol: Flag at Half Mast*. Retrieved from http://www.usask.ca/university_secretary/ceremonies/flag.php
- Parks Canada. (Retrieved 2011). *Rugby Chapel*. Retrieved from <http://www.historicplaces.ca/en/rep-reg/place-lieu.aspx?id=4994&pid=0>
- Parks Canada. (Retrieved 2012). *Ernest Lindner Studio on Fairy Island*. Retrieved from <http://www.historicplaces.ca/en/rep-reg/place-lieu.aspx?id=10429>
- Penny, C. (2003). Commemorative Integrity Statement College Building (U of S) National Historic Site of Canada DRAFT STATUS.
- Quiring, B. (Retrieved 2012). *The Encyclopedia of Saskatchewan, Douglas, Thomas Clement*. Retrieved from http://esask.uregina.ca/entry/douglas_thomas_clement_1904-86.html
- Ralko, J. (2004). *Building Our Future: A People's Architectural History of Saskatchewan*. Calgary: Red Deer Press.
- Rangacharyulu, C. Personal Communication, June 10, 2011.
- Raymond Moriyama Architects and Planners. (1978). *The Meewasin Valley Project*. Saskatoon: Raymond Moriyama.

- Rector and the Visitors of the University of Virginia. (2012) *Jefferson's Vision: Thomas Jefferson's Academical Village*. Retrieved from <http://www.virginia.edu/academicalvillage/vision.html>
- Reverend Crabb. *History of Emmanuel College*. CFQC TV. SK Archives Board.
- Richards, B. (January 8, 2010). Viewpoint: Use may change but memories remain. *On Campus News*. Retrieved from http://news.usask.ca/archived_ocn/10-jan-08/viewpoint.php
- Sanche, M. (1986). *Heartwood: A History of St. Thomas More College and Newman Centre at the University of Saskatchewan*. Muenster: St. Peter's Press. Call no. LE3.S67M6S3.
- Saskatchewan Archives Board. College of Emmanuel and St. Chad. File B124 AII.124-125.
- Saskatchewan Culture, Youth and Recreation. (2003). *Provincial Heritage Property Information Kit for the College Building, U. of S.*, Saskatoon. Retrieved from Facilities Management Division.
- Saskatoon Council of Women. (n.d.). *Background Information*. Saskatoon, SK: Saskatoon Council of Women. SK Archives Board.
- Saskatoon Heritage Society. (Retrieved 2011). *Designated Buildings: Little Stone School*. Retrieved from http://www.saskatoonheritage.ca/designated/littlestone_schoolhouse.html
- Saskatoon Heritage Society. (Retrieved 2011). *Designated Buildings: Rugby Chapel*. Retrieved from http://www.saskatoonheritage.ca/designated/rubgy_chapel.html.
- Saskatoon Public Library. (Retrieved 2012). *Popular Searches of the Local History Room Collections Database*. Retrieved from <http://spldatabase.saskatoonlibrary.ca/icswpd/exec/icswppro.dll>
- School for the Deaf Book Committee (1983). *The First Fifty Years, 1932-1982: R.J.D. Williams Provincial School for the Deaf*. Saskatoon: Prairie Graphics Ind. Ltd. Call no. LE5 .S2F57 1983.
- Silversides, B.V. (1997) *Prairie Sentinel The Story of the Canadian Grain Elevator*. Fifth House Ltd.: Calgary.
- Silversides, B. (1985). Saskatoon Architects 1905-1920. *Saskatoon History*, 3, 20-37. Call no. FC3547.4.S28no.31985.
- Ski Jumping Hill Archive. (Retrieved 2012). *Saskatoon*. Retrieved from <http://www.skisprungschanzen.com/EN/Ski+Jumps/CAN-Canada/SK-Saskatchewan/Saskatoon/0117/>

- Smith, D. (Retrieved 2012). *Diefenbaker John George*. Retrieved from <http://www.biographi.ca/009004-119.01-e.php?BioId=42125>
- Snell, G., Personal Communication, July 7, 2011.
- Spinks, J.W.T. (1972). *A Decade of Change: The University of Saskatchewan 1959-1970*. Saskatoon: University of Saskatchewan. Call no. Educ.LE.3.S72S751972.
- Spinks, J.W.T. (1968). *The University of Saskatchewan in Transition*. Regina: University of Saskatchewan. Call no. Educ.LE3.S72S75U.
- St. Andrew's Archives. STA. A. Miscellaneous Letters.
- St. Andrew's Archives. STA. I. Miscellanea.
- Taft, M. (1984). *Inside These Greystone Walls*. Saskatoon: University of Saskatchewan. Call no. LE3.S72T331984.
- Tastad, M. (April 23, 1999). May the Home of Lady Victorine be Preserved for its Heritage Status and Beauty. *On Campus News*, 6(15). Retrieved from http://news.usask.ca/archived_ocn/Apr23-99/opinion.html
- Thomas, L.H. (1959). *The University of Saskatchewan 1909-1959*. Saskatoon: University of Saskatchewan. Call no. EDUC.LE3.S72T45.
- Thompson, W.P. (1970). *The University of Saskatchewan: A Personal History*. Toronto and Buffalo: University of Toronto Press. Call no. EDUC.LE3.S72T4.
- Thomson, J.S. (1969). *Yesteryears at the University of Saskatchewan 1937-1949*. Saskatoon: Modern Press. Call no. LE3.S72T48c.3.
- Trottier, P., Personal Communication, May 29, June 22, 2012.
- University of Saskatchewan Archives. Board of Governors Agendas, University of Sask. 1911.
- University of Saskatchewan Archives. Buildings and Grounds Department 2015, 9, Memorial Gates.
- University of Saskatchewan Archives. Buildings and Grounds Department 2015, 11, Observatory.
- University of Saskatchewan Archives. Buildings and Grounds Department 2015, 12, Presbyterian College, a) Brown D.R., c) Smith Bros, e) Miscellaneous.
- University of Saskatchewan Archives. Buildings and Grounds Department Series I. Chemistry Building.

- University of Saskatchewan Archives, College of Law, RG 2082, 006 College of Law Building, 1961-1967.
- University of Saskatchewan Archives, Controller's Office Fonds, 9, Series I. Vice President - Administration. II. Building Files, 15. Emma Lake Art Campus, 1949-66.
- University of Saskatchewan Archives. Jean Murray Fonds AIII1(b) Finances.
- University of Saskatchewan Archives. Jean Murray Fonds EIIC32 President's Residence.
- University of Saskatchewan Archives. J.E. Kennedy Fonds.
- University of Saskatchewan Archives. Justice and Webb Fonds. MG 197 I. Working Files U13.1 Marquis Hall (Qu'Appelle Hall Addition) - 1962-1963.
- University of Saskatchewan Archives, MG183 Mac and Beth Hone Fonds, 7, 1.2 Personal Correspondence Ernest Lindner VP of Canadian Arts Council.
- University of Saskatchewan Archives. U of S Observatory, Kennedy Additional - Box 7.
- University of Saskatchewan Archives. President's Office Fonds, Series I. B. Name and Subject Files 71. Memorial Tablets and Gates (1918-1928).
- University of Saskatchewan Archives. President's Office Fonds, Series VI. I. Acad. And Admin. 8. VP SP. Pro. I DI and Dev. 8-3: Memorial Gates 1986-1989.
- University of Saskatchewan Archives. Presidential Papers Series III. B-116. Library (1950-1959) RG 1 S3.
- University of Saskatchewan Archives. Presidential Papers Series III. B. Name and Subject Files 116. Library (1950-1959).
- University of Saskatchewan Archives. Presidential Papers Series V. RG2001.5.
- University of Saskatchewan Archives, Publications 52., Arts and Science (College), 3, Art 1. Calendars and Timetables.
- University of Saskatchewan Archives, Publications 52., Arts and Science (College), 3, Art 2. Bulletins and Research Reports.
- University of Saskatchewan Archives, Publications 52., Arts and Science (College), 3, Art 12. Histories.
- University of Saskatchewan Archives. RG 2001.2, General Correspondence, White.
- University of Saskatchewan Archives. RGM 100, Misc. 29. U of S Viewbook - c. 1929.

University of Saskatchewan Archives, RGM 300.32, Misc. 1959 Appraisal of the University.

University of Saskatchewan Archives. (Retrieved 2011-2012). Building Chronology: Campus Buildings. Retrieved from http://scaa.sk.ca/gallery/uofs_buildings/

University of Saskatchewan Archives. (Retrieved 2012). Campus Views: Of What Never Was. Retrieved from http://scaa.usask.ca/gallery/uofs_buildings/

University of Saskatchewan Archives. (Retrieved 2013). *Events in the History of the University of Saskatchewan 1932: Broadway Bridge opens, designed by Dean of Engineering*. Retrieved from http://scaa.usask.ca/gallery/uofs_events/articles/1932.php

University of Saskatchewan Archives. (Retrieved 2012). Events in the History of the University of Saskatchewan: 1979: Diefenbaker Funeral. Retrieved from http://scaa.usask.ca/gallery/uofs_events/articles/1924.php

University of Saskatchewan Archives. (Retrieved 2011). Events in the History of the University of Saskatchewan 1925: Fire Destroys the Engineering Building. Retrieved from http://scaa.usask.ca/gallery/uofs_events/articles/1925.php

University of Saskatchewan Archives. (Retrieved 2011). Events in the History of the University of Saskatchewan 1930: William Rutherford First Dean of Agriculture. Retrieved from http://scaa.usask.ca/gallery/uofs_events/articles/1930.php

University of Saskatchewan Archives. (Retrieved 2012). Events in the History of the University of Saskatchewan 1956: Murray Memorial Library Opens. Retrieved from http://scaa.usask.ca/gallery/uofs_events/articles/1956.php

University of Saskatchewan Archives. (Retrieved 2012). Online Database. Retrieved from <http://www.usask.ca/archives/databases.php>
University of Saskatchewan Archives, School of Agriculture
Addendum A. Directors Correspondence 4. Building 1948-50.

University of Saskatchewan Archives. (Retrieved 2011). The Student Experience, Sports: In the Pool. Retrieved from http://scaa.usask.ca/gallery/uofs_students/index.php?load=pool_1

University of Saskatchewan Archives. (Retrieved 2012). Walter Murray: The Lengthened Shadow. Retrieved from <http://scaa.usask.ca/gallery/murray/index.php>

University of Saskatchewan. *Then and Now: Welcome to the University of Saskatchewan College Building Brochure*.

- U of S Observatory. (n.d.) U of S Observatory. Retrieved from <http://physics.usask.ca/observatory/>
- Vajcner, M., (Retrieved 2012). *The Encyclopedia of Saskatchewan, Morton, Arthur Silver (1870-1945)*. Retrieved from http://esask.uregina.ca/entry/mortonarthur_silver_1870-1945.html
- Village Plans. (2008). *Plans*. Retrieved from ww2.iath.virginia.edu/wilson/uva/avillage/plans/plans.html
- Walking Tour. (Retrieved 2012). G.W. Norman Printer 225 20th Street West. Retrieved from <http://www.riversdale.ca/walkingtours.php?page=gw-norman>
- Wallace, A. (2006). *Memorial Gates, University of Saskatchewan: Report on Physical and Heritage Significance*. Retrieved from Facilities Management Division.
- Warden, K. (Retrieved 2012). *Campus Myths Add Spice for First-Year Students*. Retrieved from www.brainsugar.com/media/UofSCampusMyths.doc
- Weins, L. (Fall 2001). A Great Choice: Molloy Selected as New Chancellor. *The Green and White*. Retrieved from <http://www.usask.ca/greenandwhite/issues/2001/fall2001/features1003956556.php>.
- Wheeler, E. (1967, June 15). The Little Stone School Officially Opened. *The Western Producer*, pp. 34, 35. SK Archives Board.
- Wolfson, D. (Wolfsun Productions). (2009). *Edifice & Us* [Season 2 Episode 1]. Buildings with a Heart: John Holliday-Scott's Buildings. Retrieved from <http://www.youtube.com/watch?v=14PAbvxCi4o>
- Wood, M.C. (n.d.). *Saskatoon History Hunter Goes to School*. SK Archives Board.

* SK Archives Board denotes an item retrieved from the Saskatchewan Archives Board

* Call numbers indicate the call number for the item at the University of Saskatchewan Library

8.3 Appendix: Stone

▪ **Greystone:** ‘Greystone,’ a type of dolomitic limestone, is the most common building stone in Saskatoon (Mysyk & Kulyk, 2006). Greystone is common to the area around Saskatoon and through the South Saskatchewan River valley. It was originally found and gathered on or near the surface of the soil, and is therefore often referred to locally as ‘fieldstone,’ although it is now more frequently quarried. Greystone formed 450 million years ago during the Ordovician period, but was deposited in the South Saskatchewan River valley when the glaciers of the last ice age retreated 10,000 years ago. Although it is a type of limestone, greystone is characterized by an absence of fossils, due to its formation in deep cool waters that were devoid of marine life. The term greystone is a colloquialism that refers to its colour, although it is in fact predominantly a buff colour, with some shades of yellow, pink and purple.

Greystone is a significant character-defining element of many buildings at the University of Saskatchewan, and of the campus as a whole. Its significance lies in the consistency of its use through one hundred years of building, and due to the fact that the material is local. In *Saskatchewan: The Making of a University* (1959) Arthur Morton, describes how the university Board of Directors came to choose greystone for Saskatchewan Hall and for the Agriculture Building, now the MacKinnon Building:

“The building contracts specified that the College of Agriculture (now MacKinnon) Building and the Residence (now Saskatchewan Hall) were to have exterior walls of rock-faced Tyndall stone. After the stone work was started and several car loads of Tyndall stone were either on the site or in transit, a man named James Wilson proposed that the builders use a local limestone instead. This limestone was available about six miles northeast of the site. The contractors were instructed to build a sample wall of this stone for the Board’s inspection. They did so; the Board approved of the result and ordered the substitution of the Greystone for the Tyndall. The local stone proved to be a much better stone than the Tyndall; it was harder and more impervious to moisture, and its varied colour made for a more pleasing appearance of the finished wall.”



Figure 1. Greystone.



Figure 2. Fieldstone north of campus ca. 1910. Photo A-758, retrieved from http://scaa.usask.ca/gallery/uofs_buildings/



Figure 3. Stones used for the construction of University hospital. The Thorvaldson Building is in the background. Photo A-1067, retrieved from http://scaa.usask.ca/gallery/uofs_buildings/.

This decision would come to define the character of the main campus. Greystone became the material of choice for buildings at the University of Saskatchewan, and has been used ever since. The origin of the greystone used on the early buildings at the University of Saskatchewan has not been determined with certainty. However, a recent report by Willis Kirkham, commissioned by the Meewasin Valley Authority, identifies the source of the stone as several farmsteads forming part of the ‘Northeast Swale’, a valley northeast of Saskatoon, formed by an ancient former channel of the South Saskatchewan River. University records document payments for stone between 1911-13, to several land owners in this area, including a James D. Powe and a C.S. Copp (Kirkham, 2012). The Northeast Swale also shows significant evidence of quarrying activity.

A 1916 report by William A. Parks identifies a ridge, about 2.25 miles from Saskatoon, “rich in boulders which have been utilized for the construction of the building of the University of Saskatchewan.” The author identifies the origin of the stone as an elevated ridge of glacial material on the southeast side of the Saskatchewan River, near Clarksboro. Parks states that the buildings of the University of Saskatchewan are constructed of a “pinkish Silurian limestone.” (1916).

The greystone used for current projects at the University of Saskatchewan is sourced from various locations, depending on the masonry contractor and on availability. Gracom, who have carried out the masonry work on several recent construction projects, currently obtain greystone from a site in north-eastern Saskatchewan in the Deschambault Lake region. This dolomite does not come in the fieldstone or boulder format more commonly found in the Saskatoon region, but in the form of large slabs beneath the base soil, and is quarried.



Figure 4. 1912, surplus greystone shortly after the completion of the MacKinnon Building. Photo A-758, retrieved from http://scaa.usask.ca/gallery/uofs_buildings/

■ **Tyndall Stone:** Tyndall stone is named for its origin, the area around Tyndall, in southeast Manitoba. The stone was first used in the construction of Fort Garry in 1832, north of modern day Winnipeg. Tyndall stone fabricators August Gillis and Sons purchased their first quarry in 1915 and incorporated as Gillis Quarries Ltd. in 1922. Gillis Quarries now owns over 1800 acres of quarriable land. Notable buildings featuring Tyndall stone include the Parliament Buildings in Ottawa and the Canadian Museum of Civilization in Hull, Quebec.

Tyndall stone is a dolomitic limestone characterized by its light grey colour, mottled appearance and visible fossils. The fossils in Tyndall stone are a result of the way in which the stone was formed. 450 million years ago, much of Saskatchewan and southern Manitoba was covered by a vast, shallow, inland sea. Marine animals, such as corals, sponges, molluscs, trilobites and stromatoporoids, lived on or above the soft, muddy sea floor. After they died, their remains settled into the mud, and became fossilized over time. The calcium carbonate in their skeletons and shells, mixed with silt, became limestone. The fossil remains of these animals are visible in Tyndall Stone. The channels formed by burrowing animals created the worm-like mottling which gives Tyndall Stone its characteristic mottled appearance. Tyndall stone is sometimes called ‘tapestry stone’ due to this patterning. Geologically, Tyndall stone is referred to as ‘Upper Mottled Limestone of the Red River Formation of the Ordovician System’.

At the University of Saskatchewan, Tyndall stone replaced Indiana Limestone as the most common stone used for cut and carved stone ornamentation after the Second World War. Its first use appears to have been on the Health Science building (now the Academic Health Sciences A Wing), which began construction in 1945. It was used more extensively, as a wall cladding material, on parts of the Murray Memorial Library in 1954. Tyndall stone was the material originally chosen for the exterior walls of the first buildings at the University of Saskatchewan in 1910; however, the local availability of greystone made it the preferred choice. (Refer to Greystone, above). The common use of Tyndall Stone at the University of Saskatchewan has made it an important character-defining element.

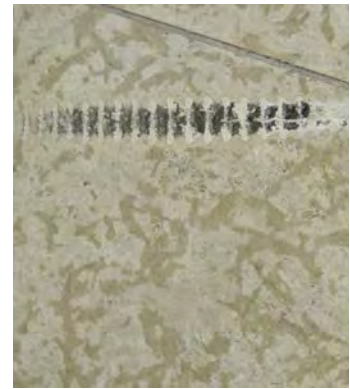

Figure 5. Tyndall stone showing fossil remains and characteristic mottling.

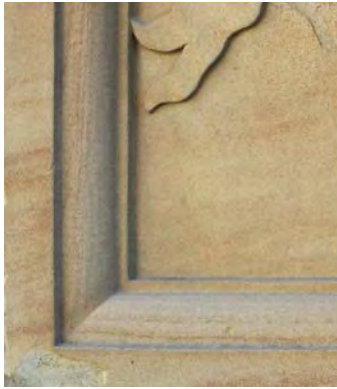

Figure 6. Sandstone.



Figure 7. Indiana Limestone.

■ **Sandstone:** Berea Sandstone is a sedimentary rock composed mainly of sand-sized grains of quartz and other minerals, bonded by silica and lime. Berea sandstone was formed during the Carboniferous period, between 360 to 300 million years ago. Berea Sandstone was used for cut and carved stone ornamentation on the earliest buildings at the University of Saskatchewan, such as the MacKinnon Building (1910-12), Saskatchewan Hall (1910-12), and the College of Emmanuel and St. Chad (1910-12). Beginning with Qu'Appelle Hall in 1914, Salem or Indiana limestone replaced the use of sandstone because it was found to be more durable and easier to carve (Mysyk & Kulyk, 2006).

The 'Berea' is a geological formation of sandstone in northeast Ohio, where this stone is quarried. Cleveland Quarries began quarrying the stone, located near Amherst and Birmingham, in 1868. The company owns over 1000 acres which contain over 300 million cubic feet of sandstone deposits. The Berea formation has produced a total of 500 million cubic feet of sandstone to date.

■ **Indiana Limestone:** Indiana Limestone, also known as Bedford or Salem Limestone, is a sedimentary rock composed primarily of calcium carbonate. Indiana Limestone was formed during the early Carboniferous period, between 360 and 323 million years ago. It was formed from the remains of marine organisms, which were deposited as sediment over millions of years at the bottom of a shallow inland sea which covered most of the present-day Midwestern United States. Indiana Limestone is a light buff-coloured stone, with consistent colour and a fine-grained texture, known for the ease with which it is cut, split and carved. Beginning with Qu'Appelle Hall in 1914, Indiana limestone replaced the use of sandstone because it was found to be more durable and easier to carve (Mysyk & Kulyk, 2006). Other buildings constructed with Indiana Limestone trim include the Chemistry Building (1919-21), the Physics (Thorvaldson) Building (1922-24), and the Memorial Gates (1927-28).

The Indiana Limestone Company started quarrying limestone in the mid-1800s, and has grown to be the largest limestone quarrier and fabricator in North America. The Indiana Limestone Company owns over 4000 acres containing in excess of 100 years worth of reserves. Notable buildings built with Indiana Limestone include the Empire State Building and the Pentagon (Indiana Limestone Company, 2013).

▪ **Granite:** Granite is a common type of igneous rock composed mainly of quartz, mica and feldspar. Granite is a product of the slow crystallization of magma under the earth's crust. The 'flecks' in granite are mineral grains that are large enough to be visible to the naked eye. Granite is most often quarried as a 'dimension stone.' A dimension stone is a rock that has been cut into blocks or slabs of specific length, width and thickness. Granite is exceptionally hard, durable, and resistant to chemical erosion from salts or acids, and has therefore gained widespread use as a building stone. In its architectural applications it may be finished with a rough face, a smooth cut face, it may be honed or polished to a high sheen.

At the University of Saskatchewan, Granite has commonly been used to form base courses and steps, for example, on the MacKinnon Building (1910-12) or the Physics (Thorvaldson) Building (1922-24). The granite typically seen at the university for these applications is light grey in colour. On later buildings, such as the Murray memorial Library (1954-56), pink granite panels were used as a wall cladding on the entry vestibule.

Most granite at the University of Saskatchewan is cut. The Stone Barn (1910-12) is an exception; its ground floor walls are composed of rough-faced granite of a darker variety.

▪ **Slate:** Slate is a fine-grained homogenous metamorphic rock formed from shale. With heat and compression, the clay in shale turns into mica which transforms the mineral from shale to slate. Slate is most commonly used for roofing tiles. The properties and formation of slate make it easy to cut into thin sheets for this application. In addition, slate is a water-shedding material and withstands contact with freezing water.

Slate tile roofing and slate stair treads were used on most University of Saskatchewan buildings during the first phase of construction from 1909-1929. The slate tile at the University of Saskatchewan is characteristically green in colour. Many of staircases on early university buildings, such as those in the MacKinnon Building (1910-12), feature original slate treads which show grooves from years of use. In some places, black slate is used. There are still some black slate chalkboards in use on campus; the lecture theatre in the Thorvaldson Building (1922-24) is one example.



Figure 8. Top to Bottom : Grey dimension cut granite bollard, rough cut, dark granite wall, polished red granite.

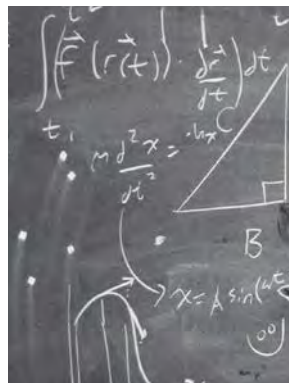

Figure 9. L to R: slate roof tiles, natural cleft slate surface, slate chalkboard.



Figure 10. Top to Bottom:
White marble, green marble.

▪ **Marble:** Marble is a metamorphic rock composed of recrystallized carbonate minerals, most commonly calcium or dolomite. It is formed from the heat and compression of limestone. Marble will take a high polish, and is most often used as an interior finish material.

Marble is seen in its most abundant use in the first residence buildings at the university: Saskatchewan Hall and Qu'Appelle Hall. It is found in the washrooms of Saskatchewan Hall and in the bedrooms and corridors of Qu'Appelle Hall. The window sills, baseboards stair treads and landings in Qu'Appelle Hall are composed of white marble. Some of the original white marble has been replaced with a locally available, green variety. The swirls and veins of coloration found in marble are due to mineral impurities. The colour green is most often indicative of high magnesium limestone or dolostone with silica impurities.

Supporting Documents for Appendix: Stone

Cleveland Quarries. (2013). About Cleveland Quarries. Retrieved from <http://www.clevelandquarries.com/about>

Geology.com. (2013). Slate - Metamorphic Rock. Retrieved from <http://geology.com/rocks/slate.shtml>

Gillis Quarries. (2013). Gillis Quarries - Company Information. Retrieved from <http://www.tyndallstone.com/companyindex.html>

Hill, B. Personal Communication. August 19, 2013.

Indiana Limestone Company (2013). About ILC. Retrieved from <http://www.indianalimestonecompany.com/>

Mysyk, W.K. & Kulyk, C.L. (2006). *Saskatoon's Stone*. Saskatoon: Houghton Boston Printers & Lithographers Ltd.

Parks, W. A. (1916). *Report on the building and ornamental stones of Canada*. Ottawa : Govt Print Bureau.

Wikipedia. (Retrieved 2013). Marble. Retrieved from <http://en.wikipedia.org/wiki/Marble>